

## ADAS User Manual

- [FCW - Multi-Target \(Moving Base\)](#)
- [FCW - Multi-Target \(Static Base\)](#)
- [FCW - Single Target \(Moving Base\)](#)
- [FCW - Single Target \(Static Base\)](#)
- [FCW - Static Point \(Static Base\)](#)
- [LDWS - Curved Lane](#)
- [LDWS - Straight Lane](#)
- [LDWS - Video](#)
- [Park Assist - Straight Lane](#)
- [VBOX File Processor - Park Assist](#)
- [TSR - Traffic Sign Recognition Testing \(Multi Static Point\)](#)
- [ADAS CAN Input Configurations](#)
- [ADAS CAN outputs](#)
- [ADAS Parameter definitions](#)

## FCW - Multi-Target (Moving Base)

---

### Multiple Vehicle Targets

This mode facilitates the ability for vehicle separation parameters to be calculated at the Subject vehicle with respect to two Target vehicles.

This system consists of a VB3iSL-RTK in each Target vehicle and a VB3iSL-RTK in the Subject vehicle.

**NOTE: It is not possible to operate in Duplex mode with multiple Target vehicles.**

High accuracy of the vehicle separation calculations is made possible by the use of a Moving Base solution.

Moving Base solution removes the need for a fixed Base Station to obtain accurate GPS position, thereby allowing vehicle separation testing to be carried out in real world environments and without the restrictions of Base Station radio range.

The Target VBOX (tracked vehicle) will also log the normal GPS data to a .vbo file, so that the files from each VBOX can be compared in the VBOX Tools Graph screen or VBOX Test Suite Chart screen. This is useful to see the relative positions.

Configuration of the VBOX's is done through VBOX Manager (RLVBFMAN).

---

### Hardware Configuration

The following diagrams show the recommended hardware configuration for each Vehicle. The items greyed out are not essential but many customers may find them beneficial.

Connection between the VB3i and computer should be made via USB or Bluetooth to ensure optimum performance.

**Please ensure that all vehicle antennas are correctly positioned and connected.**



# Subject Vehicle

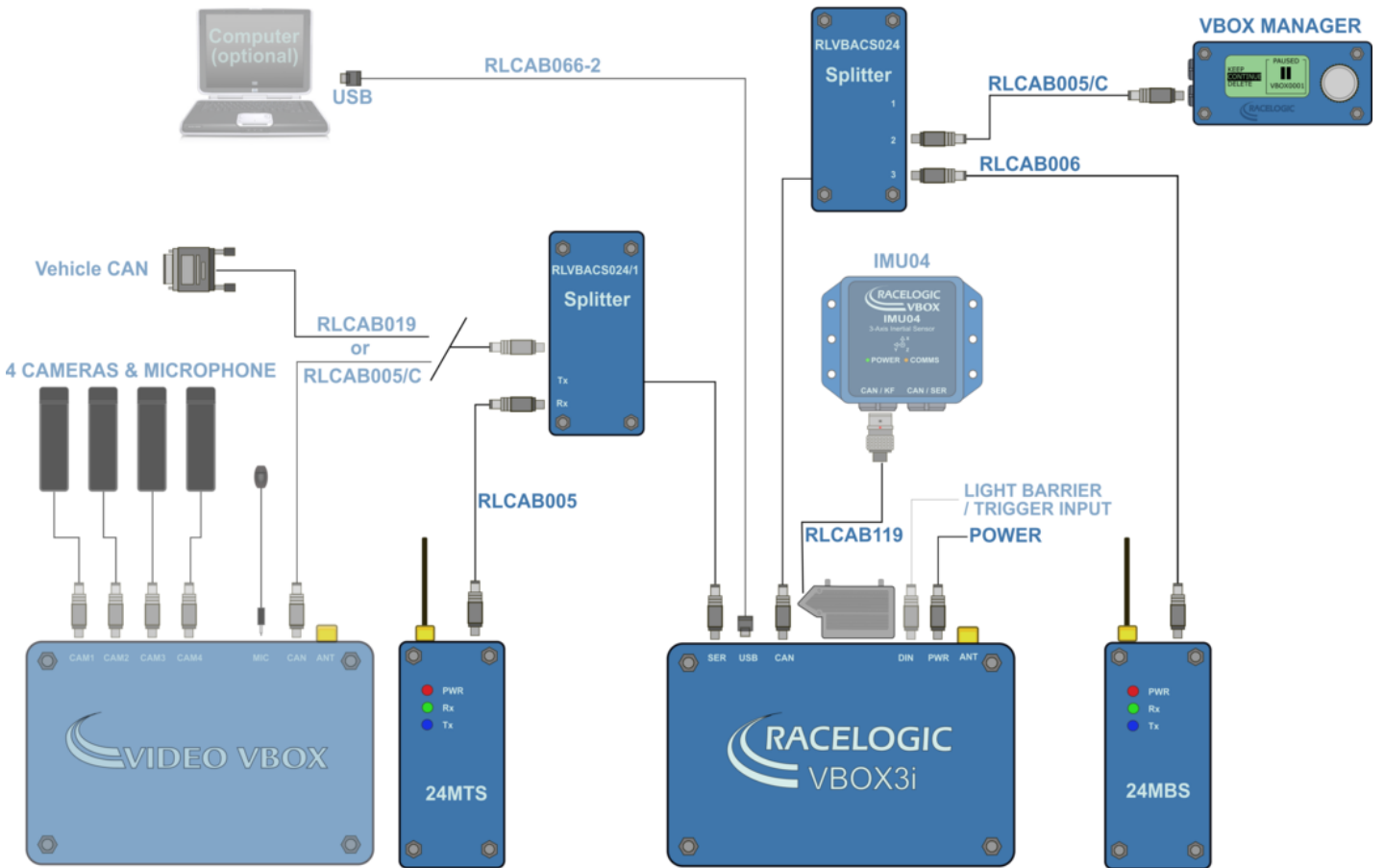

# Target Vehicle

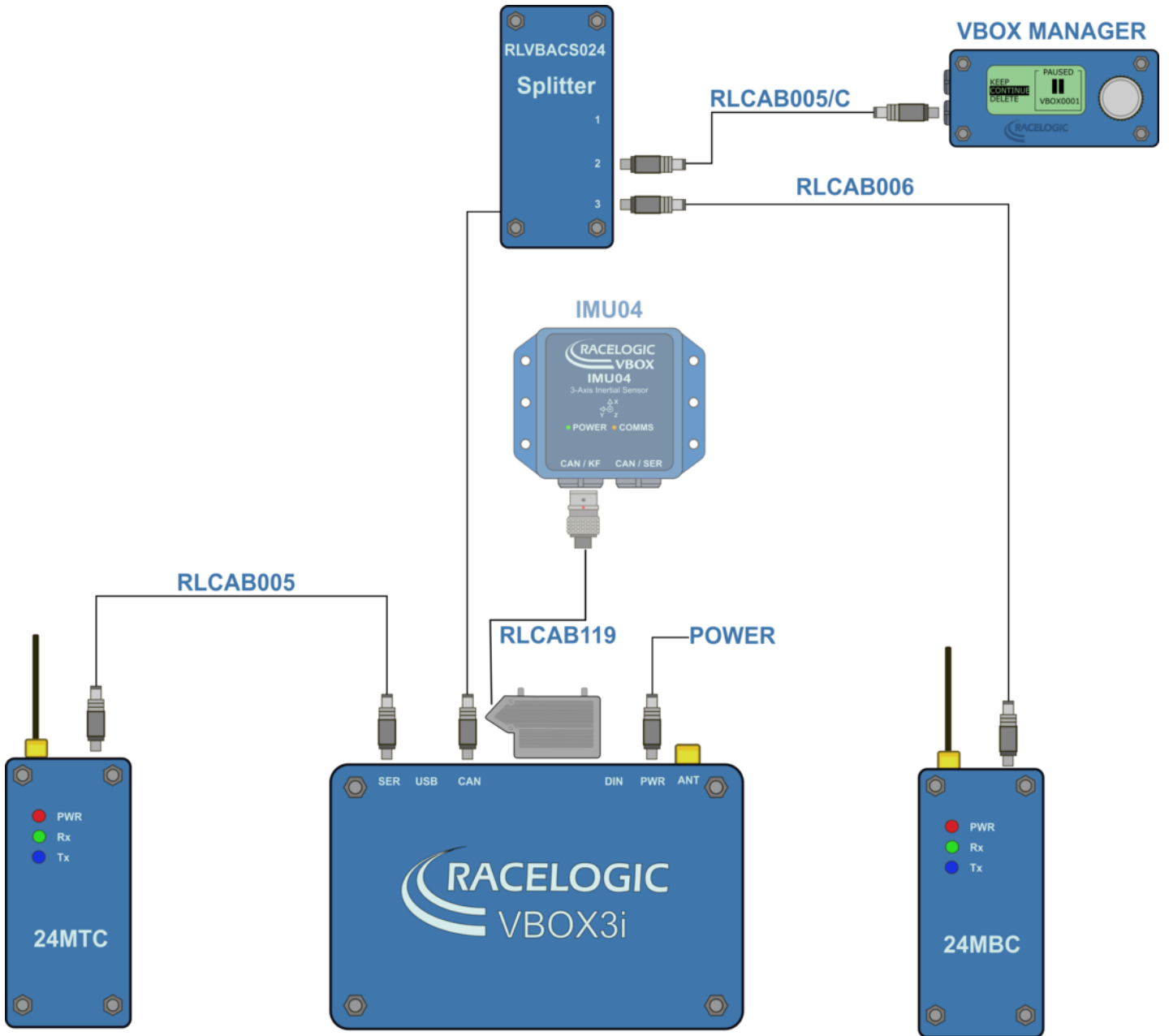



---

## VBOX Configuration

This guide assumes the use of a moving base solution.

### Target Vehicle 1

1. Connect VBOX Manager to the VBOX in Target Vehicle 1.
2. Enter the setup menu of VBOX Manager.
3. Select the '**VBOX**' option.
4. Select '**LOG RATE**' and set the rate to '**100 Hz**', then select '**BACK**' to return to the '**VBOX**' setup menu.

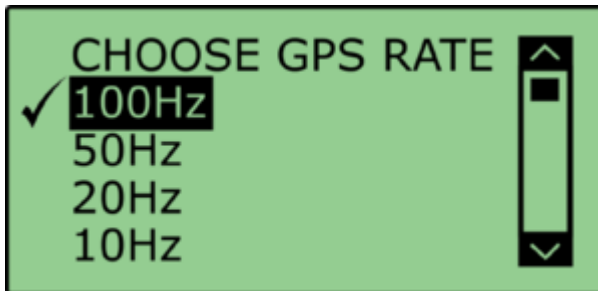

5. Select '**DYNAMICS**' and set the dynamic mode to '**NORMAL**', this Dynamics mode is best for ADAS tests, return to the '**VBOX**' setup menu.

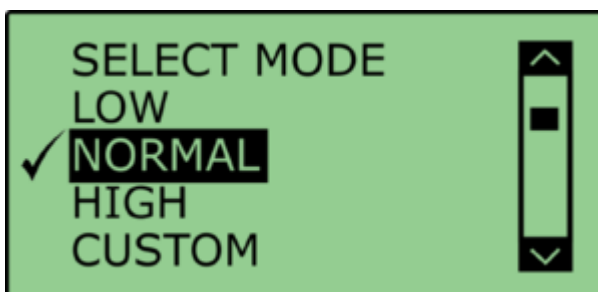

6. Select '**DGPS**' and set the DGPS mode to '**MB Rover**', return to the '**VBOX**' setup menu.

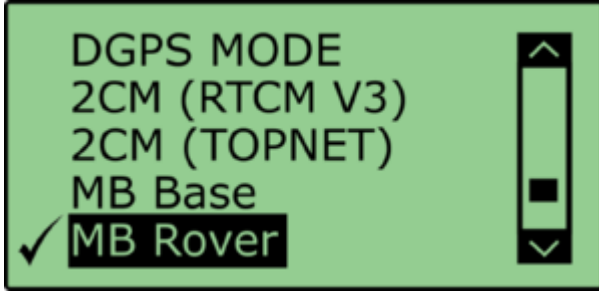

7. Select '**DGPS RS232 Rate**' and select the appropriate settings for your radios, return to the '**VBOX**' setup menu.

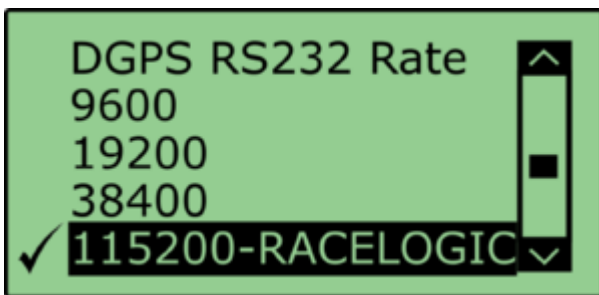

**Note:** To ensure that the VBOX receives the DGPS correction signal, the correct RS232 rate must be set. All Racelogic blue boxed radios use 115200 kbit/s, Satel grey boxed radios use either 19200 kbit/s or 38400 kbit/s.

8. Return to the main setup menu and select the '**ADAS**' option, then select '**MULTI. TARGET**' mode.

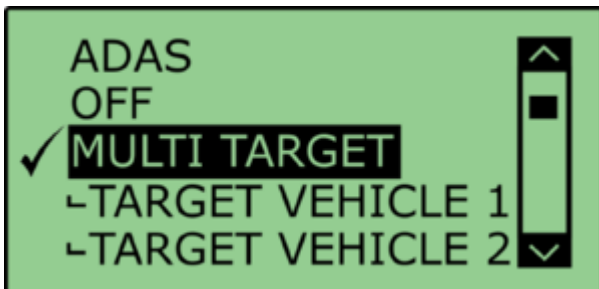

9. Select '**TARGET VEHICLE 1**' and return to the '**ADAS**' setup menu.

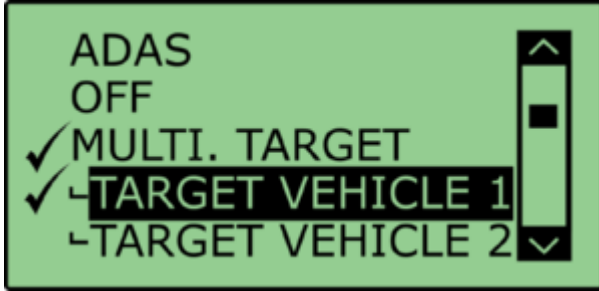

### Target Vehicle 2

1. Connect VBOX Manager to the VBOX in Target Vehicle 2.
2. Repeat steps 2 – 8 in section 'Target Vehicle 1' above.
3. Select '**TARGET VEHICLE 2**' and return to the '**ADAS**' setup menu.



### Subject Vehicle

1. Connect VBOX Manager to the VBOX in the Subject Vehicle.
2. Repeat steps 2 – 5 in section 'Target Vehicle 1' above.



3. Select '**DGPS**' and set the DGPS mode to '**MB Base**', return to the '**VBOX**' setup menu.

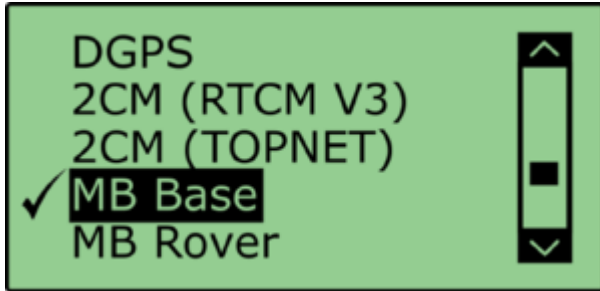

4. Select '**DGPS RS232 Rate**' and ensure that '**115200**' is selected, return to the '**VBOX**' setup menu.

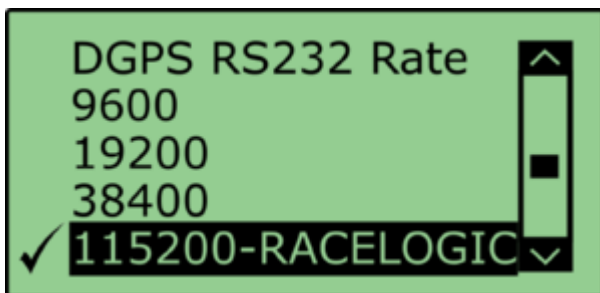

5. Select '**MULTI. TARGET**' mode and select '**SUBJECT VEHICLE**', return to the '**ADAS**' setup menu.

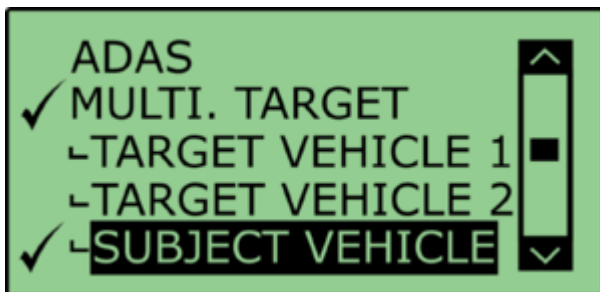

### RTK Status Indication

As the Subject Vehicle effectively becomes the Base Station it will not physically go into an RTK lock, therefore the 'DIFF' LED of the Subject VBOX will **NOT** illuminate. The 'DIFF' LED of the Target VBOX's should gain RTK FIXED status indicated by the 'DIFF' LED illuminating green.



## ADAS Radio Link

For Multiple-Target mode, you must use radio modems programmed with different configuration scripts. It is not possible to use the normal ADAS link radios.

The Radios at each **TARGET VBOX** need to be set to **CLIENT** mode and paired to the singular ADAS radio at the subject vehicle.

The radio at the subject vehicle needs to be set to **SERVER** and **BROADCAST** mode

1. Ensure the 2.4 GHz telemetry modems are connected as shown in [subject vehicle configuration](#) and [target vehicle configuration](#).
2. As 2.4 GHz transmissions are very direct, with a narrow beam width, care needs taking when mounting the antenna; ensure they are:
  - On the highest part of the vehicle roof
  - Away from any nearby obstructions that could cause a potential blockage to the path of the signal
  - Mounted vertically to ensure maximum transmission power in the horizontal plane
  - Mounted at least 50 cm away from other Radio antennas

When the 2.4 GHz modems are connected correctly the 'SER' light on the SUBJECT VBOX will illuminate, indicating the reception of a serial data stream.



---

## Pre-Test Configuration

### Setting The Contact Points

After selecting the Subject Vehicle in either the multi or single target modes, the user can set the contact points by entering the '**CONTACT POINTS**' Menu.



In this menu, it is possible to define contact points for either the 'Subject Vehicle' or 'Target Vehicle'. You can manually configure up to 2 contact points by entering a numerical offset, or you can set up to 24 contact points by using a GPS antenna.

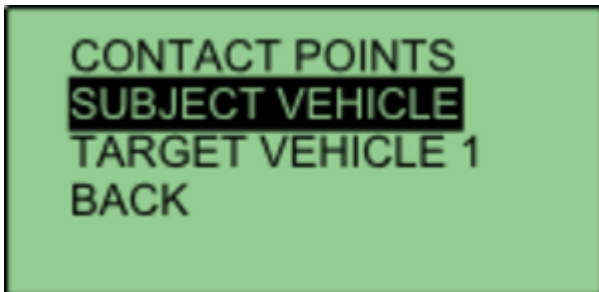

## Manually Entering Contact Points

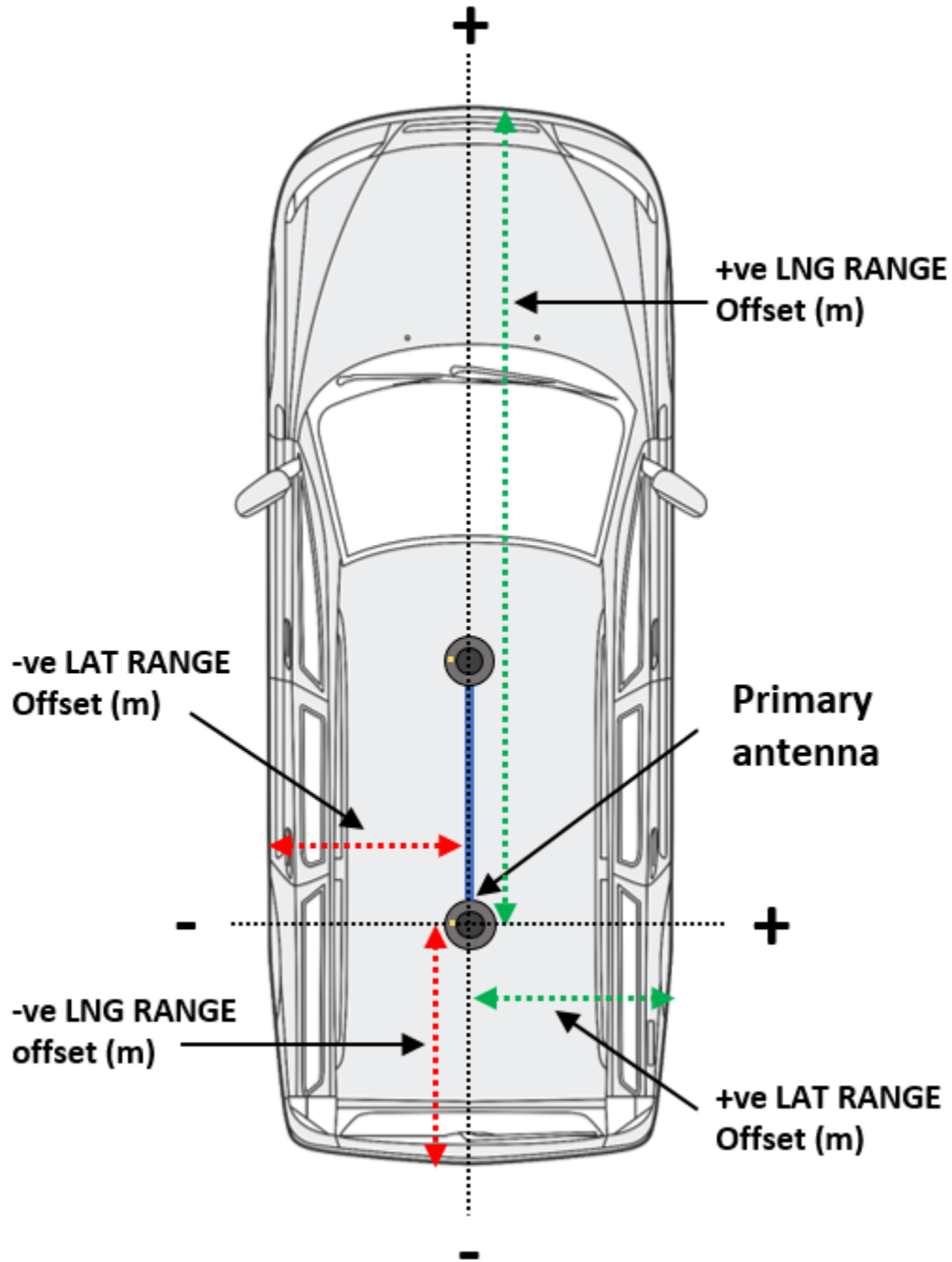

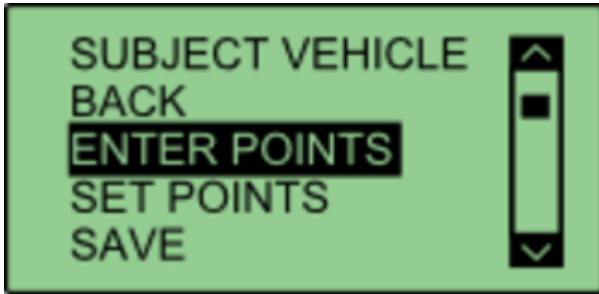

Select either '**SUBJECT VEHICLE**' or '**TARGET VEHICLE**' in the contact points menu.

Select '**ENTER POINTS**'.

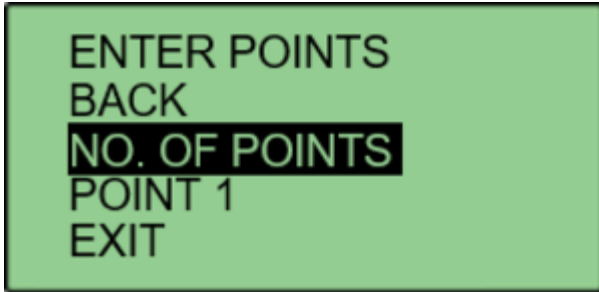

Select '**NO. OF POINTS**'.

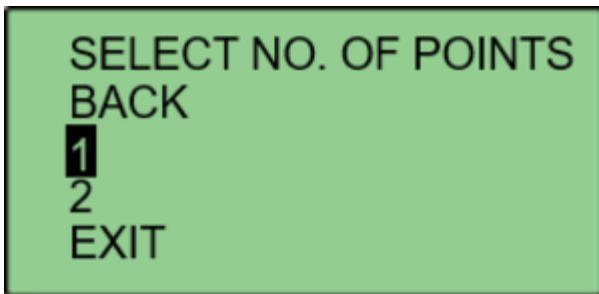

This menu allows the user to select whether 1 or 2 contact points are to be specified. The current number of selected points is highlighted with a tick next to the number. Selecting a different number will move that tick to that number. Select '**BACK**' once completed.

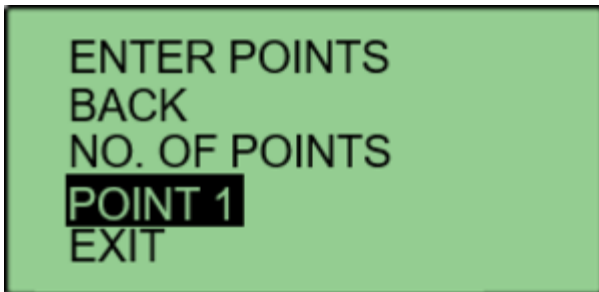

Select '**POINT 1**' to specify first contact point.





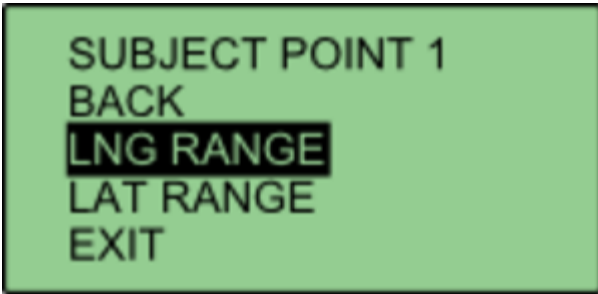

This menu allows the user to translate the **Primary** antenna point (or IMU if IMU integration is enabled) to a desired reference point on the vehicle. This is done by entering a numerical longitudinal ('LNG RANGE') and lateral ('LAT RANGE') offset value.



Selecting '**LNG RANGE**' allows the user to enter a longitudinal offset, with a forward offset being **POSITIVE** and a rearward offset being **NEGATIVE**. Pressing '**APPLY**' will store the value.



Selecting '**LAT RANGE**' allows the user to enter a lateral offset, with a rightwards offset being **POSITIVE** and a leftwards offset being **NEGATIVE**. Pressing '**APPLY**' will store the value. Select '**BACK**' to return to the previous menu.

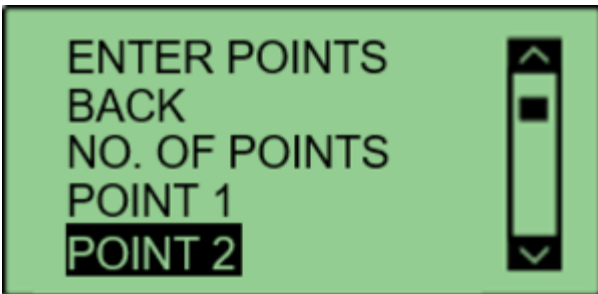

If the user selected 2 contact points in **NO. OF POINTS**, **POINT 2** will be displayed on the menu. Select '**POINT 2**' and repeat the above process.

Repeat this process to define the other vehicle.



## Setting Up To 24 Contact Points

Media, iframe, embed and object tags are not supported inside of a PDF.

First, connect a ground plane antenna to the VBOX.  
Select either '**SUBJECT VEHICLE**' or '**TARGET VEHICLE**' in the contact points menu. Select '**SET POINTS**'.

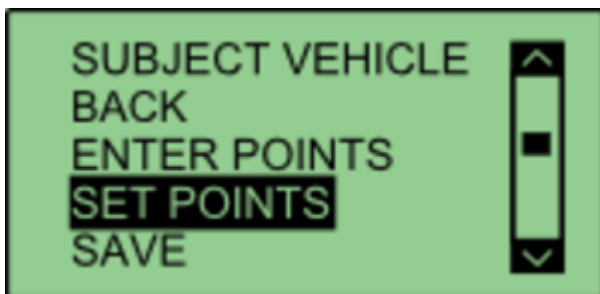

Using the survey pole, move the antenna to the desired contact point on the vehicle. Ensure there is a fixed RTK solution and select '**SET POINT**'.

If successful, VBOX Manager will display '**POINT 1 SAVED**'.

If there is no RTK fix, the point will not be saved and VBOX Manager will display '**POINT 1 NOT SET, NOT RTK FIXED**'.

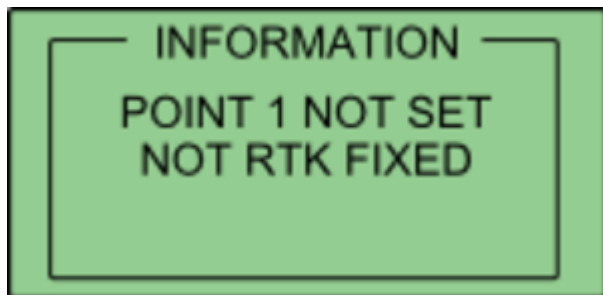

To set the next point, move the antenna to another desired point of contact and repeat the process. Repeat this process until all the desired points are set, or a limit of 24 is reached.

Once all the desired points are set, move the antenna to the location of antenna A and select '**SET ANT A**'.

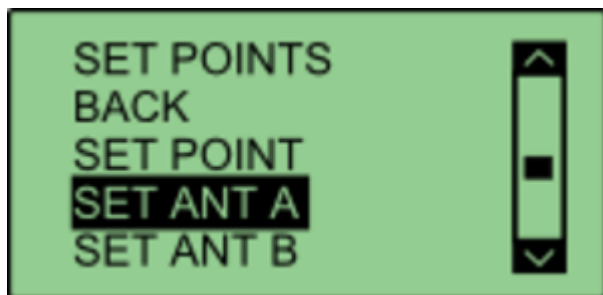

Then move the antenna to the location of Antenna B and select '**SET ANT B**'. This process can be repeated to define the other vehicle.

If multiple points have been set on either vehicle, the calculated ADAS parameters (range, angle etc) will always reference the nearest surveyed point.



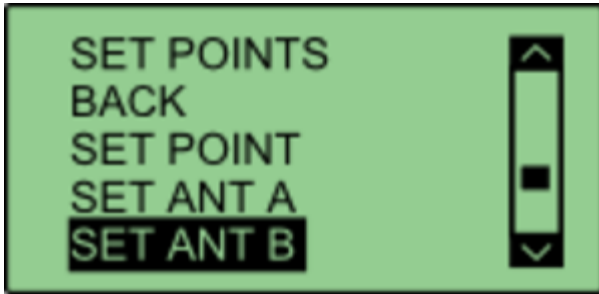

### Saving Vehicle Contact Points

After the required contact points have been surveyed, it is possible to save these points to the compact flash card by selecting '**SAVE**'.

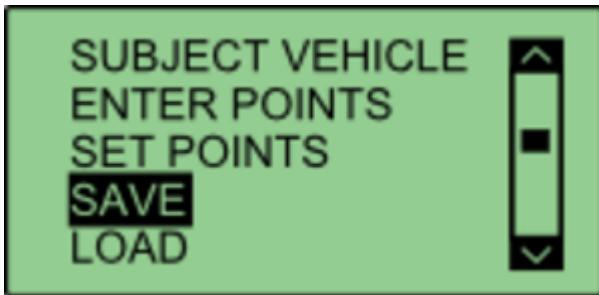

This allows the user to either overwrite a previously saved file, or create a new save file using the '**{CREATE NEW}**' option.

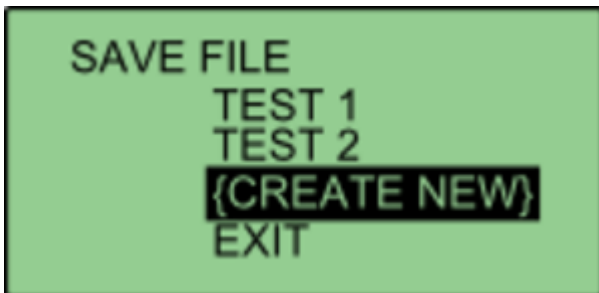

Selecting the '{**CREATE NEW**}' option will display an alpha numeric scroll wheel where the user can enter the desired file name.

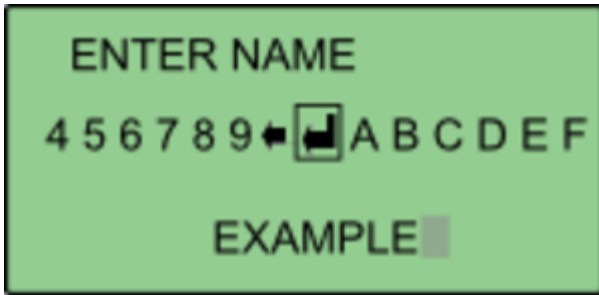

Once entered, VBOX Manager will display the '**SAVE SUCCESSFUL**' message.

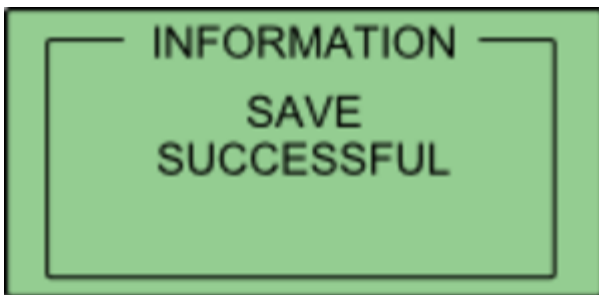

### Loading Vehicle Points

Select either '**SUBJECT VEHICLE**' or '**TARGET VEHICLE**' in the contact points menu. Then select '**LOAD**'.

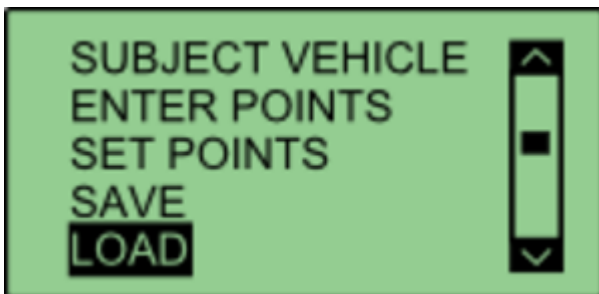

This will bring up a list of all previously saved files, which the user can select to load.

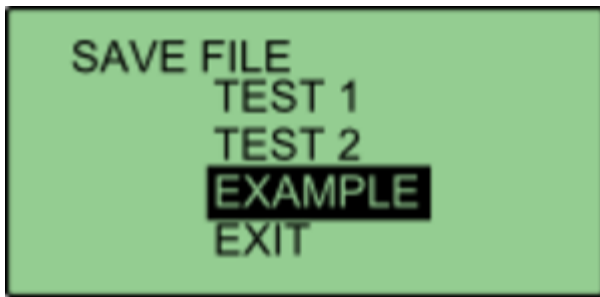

If successful, VBOX Manager will display '**LOAD SUCCESSFUL**'.

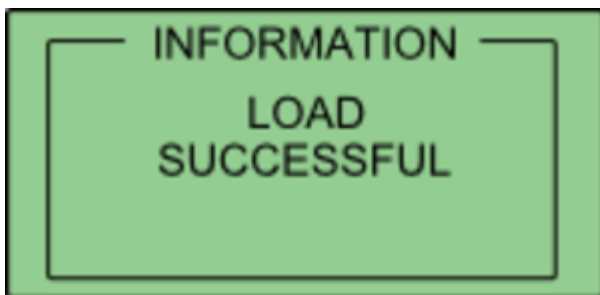

## Smoothing

If the box is set into twin antenna mode, the smoothing menu will not be present as the calculations will run off of the True heading provided by the twin antenna lock.

It is recommended that if user intends to set multiple points on the car, they enable the dual antenna.

There are two configurable variables linked to heading smoothing; 'Smoothing Distance' and 'Speed Threshold'. Due to the nature of the vehicle separation measurement and calculation process many channels are derived using the heading of the vehicle which can inherently be noisy. To overcome this heading can be smoothed with a dynamic smoothing routine.



## Smoothing Distance

The vehicle heading is normally calculated between the current and previous sample. Even with the stability of RTK position GPS position can vary by a few millimetres with respect to the original. When the travelled distance between subsequent samples is short (low speeds) this leads to a potential larger potential error in the calculated heading.

This smoothing routine allows the user to force a 'Smoothing Distance' over which heading is calculated. This is therefore dynamic, resulting in a variable number of samples used to determine the smoothing level on the heading; the lower the speed the more samples that are used. With 100 Hz logging and a smoothing distance of 1 m at 72 km/h, the heading is calculated over the previous 5 samples, whilst at 15 km/h the heading would be calculated over the previous 26 samples.

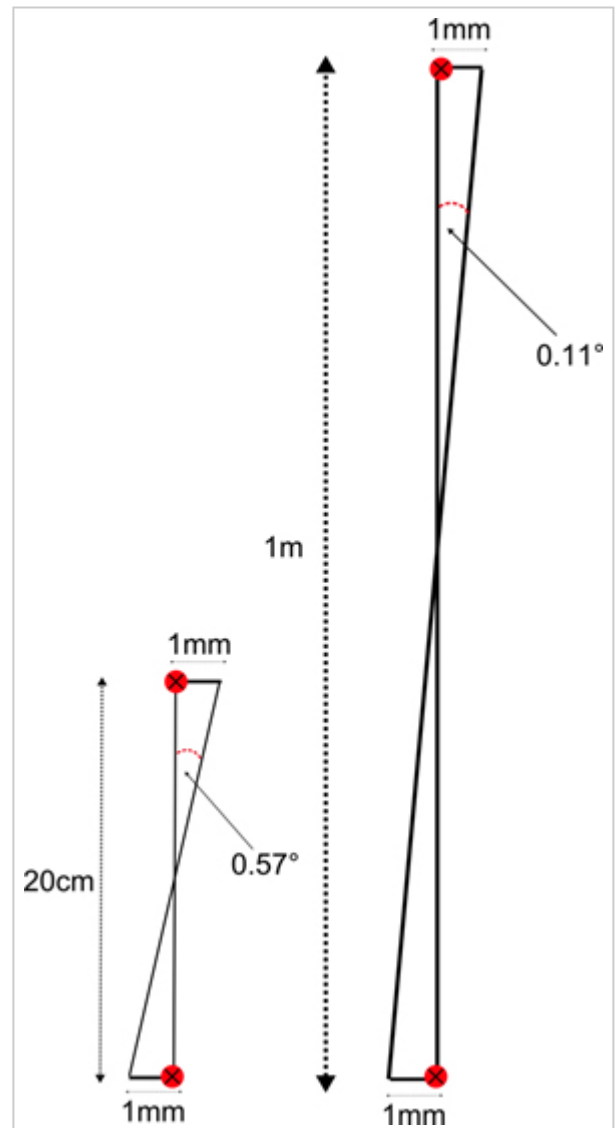

Vehicle travelling at 20 km/h in a straight path (not to scale)

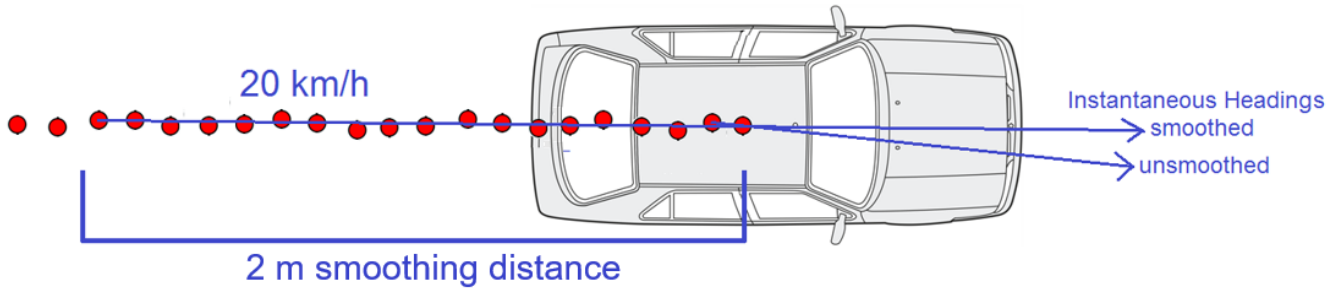

Above: Shows the improvement on vehicle heading from using smoothing distance

### Setting A Smoothing Distance

1. Using VBOX Manager, go to the '**ADAS**' menu and go to the '**MULTI. TARGET**' menu and select '**SUBJECT VEHICLE**'.

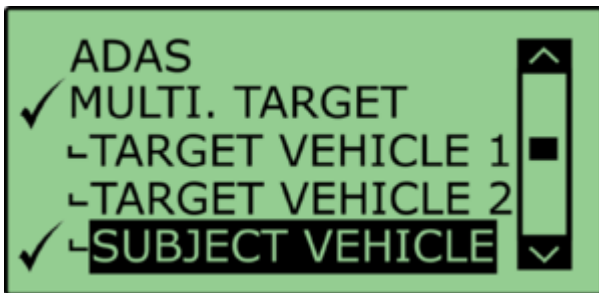

2. Select '**SMOOTHING**' from the '**SUBJECT VEHICLE**' menu.





3. Select '**SMOOTHING DIST**' and enter the smoothing option for the Subject Vehicle, from the options between 0.00 m and 2.00 m.

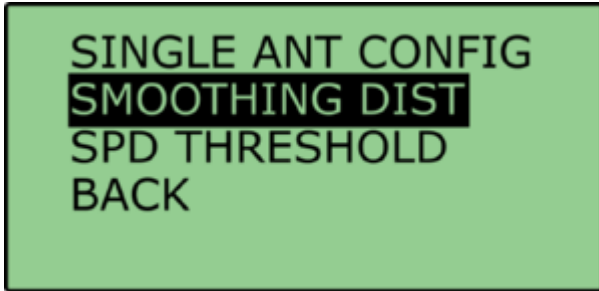

4. For typical Vehicle Separation applications we recommend a smoothing distance of 1 m.

### Speed Threshold

Due to the nature of how heading is calculated, even when Smoothing is applied at very low speeds and when the vehicle is stationary the heading channel can become very noisy and unusable, this in turn results in many of the Vehicle Separation channels becoming noisy at low speed and unusable when stationary. This is solved by fixing the heading below a configurable Speed Threshold.

1. To set the speed threshold repeat steps 1 and 2 above, then select '**SPD THRESHOLD**' and enter the speed threshold option for the Subject Vehicle.

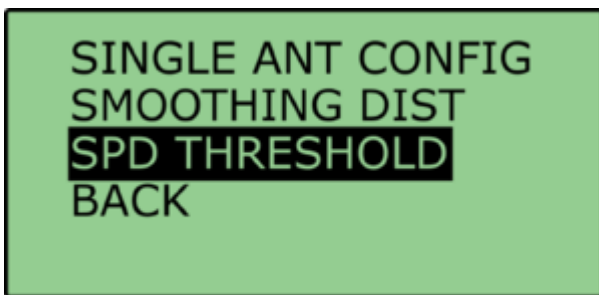

2. We recommend a Speed Threshold of 5 km/h.



## FCW - Multi-Target (Static Base)

---

### Multiple Vehicle Targets

This mode facilitates the ability for vehicle separation parameters to be calculated at the Subject vehicle with respect to two Target vehicles.

This system consists of a VB3iSL-RTK in each Target vehicle and a VB3iSL-RTK in the Subject vehicle.

**NOTE: It is not possible to operate in Duplex mode with multiple Target vehicles.**

High accuracy of the vehicle separation calculations is made possible by the use of a Static Base Station.

The Target VBOX (tracked vehicle) will also log the normal GPS data to a .vbo file, so that the files from each VBOX can be compared in the VBOX Tools Graph screen or VBOX Test Suite Chart screen. This is useful to see the relative positions.

Configuration of the VBOX's is done through VBOX Manager (RLVBFMAN).

---

### Hardware configuration

Testing with two target vehicles requires the installation of three VBOX ADAS systems, one in the Subject Vehicle and one in each Target Vehicle. The following diagrams show the recommended hardware configuration for each vehicle. The items greyed out are not essential but many customers may find them beneficial.

Connection between the VB3i and computer should be made via USB or Bluetooth to ensure optimum performance.

**Please ensure that all vehicle antennas are correctly positioned and connected.**



# Subject Vehicle

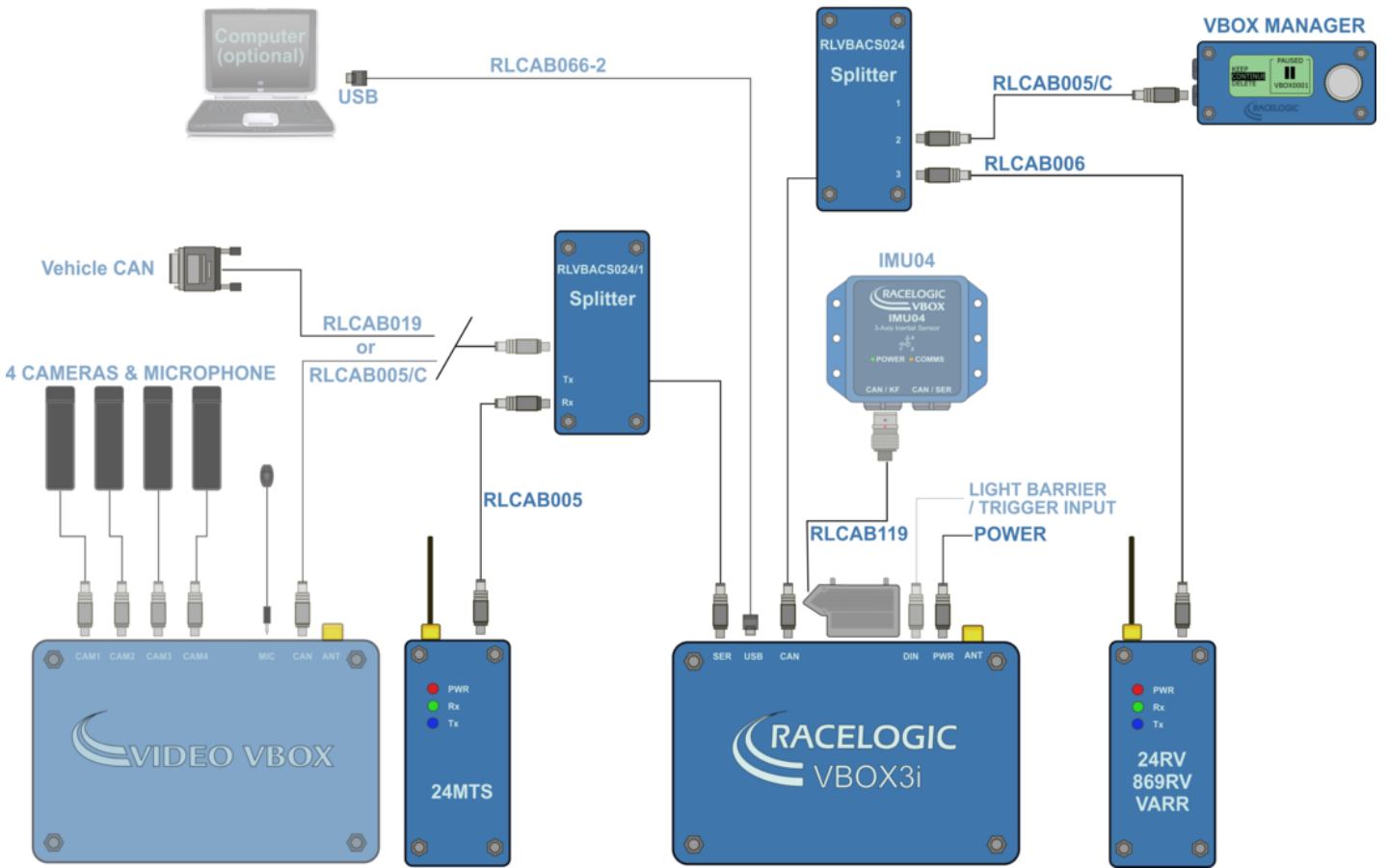

# Target Vehicle

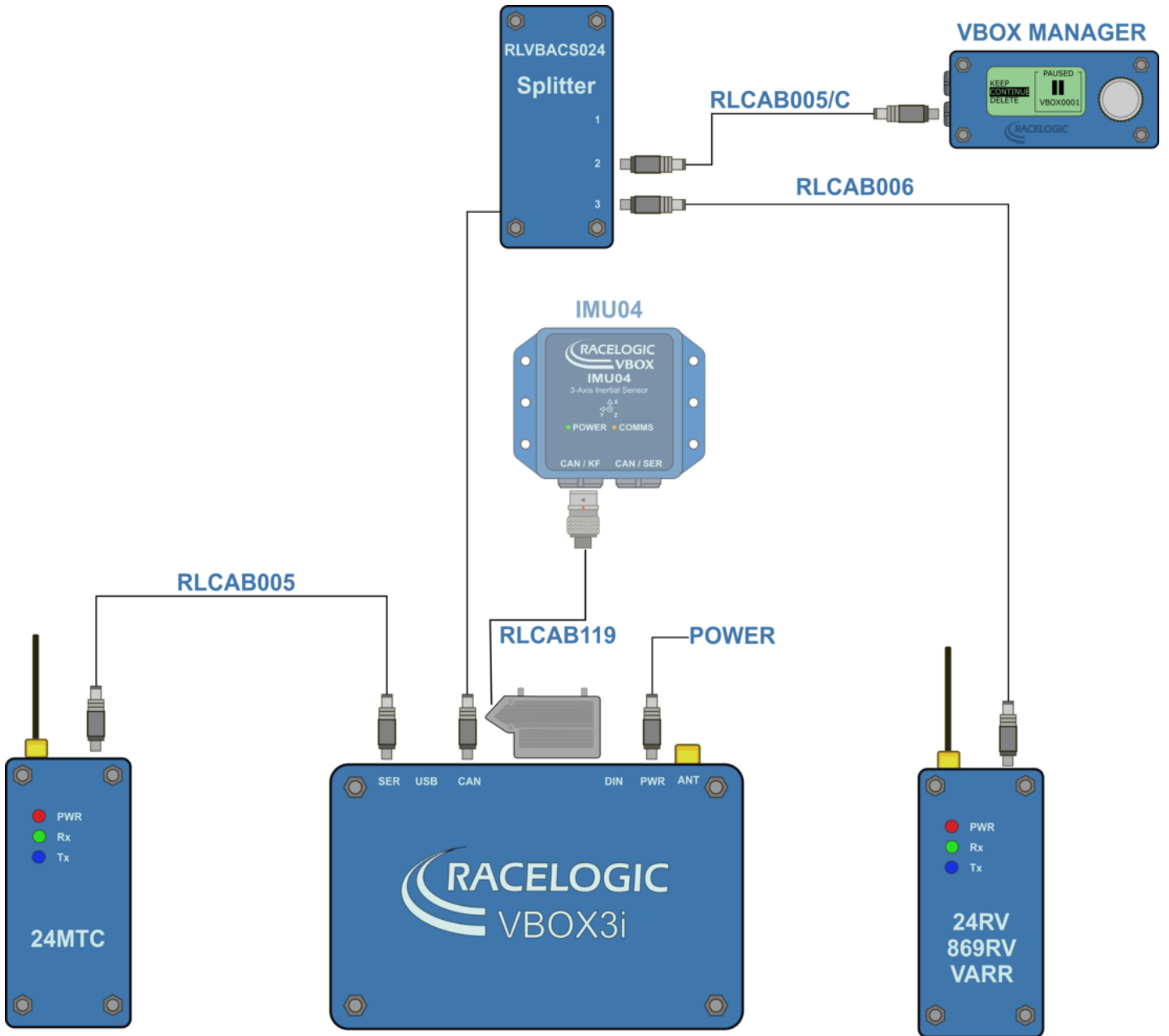

---

## VBOX Configuration

### Target Vehicle 1

This guide assumes the use of a Base Station.

1. Connect VBOX Manager to the VBOX in Target Vehicle 1.
2. Enter the setup menu of VBOX Manager.
3. Select the '**VBOX**' option.
4. Select '**LOG RATE**' and set the rate to '**100 Hz**', then select '**BACK**' to return to the '**VBOX**' setup menu.

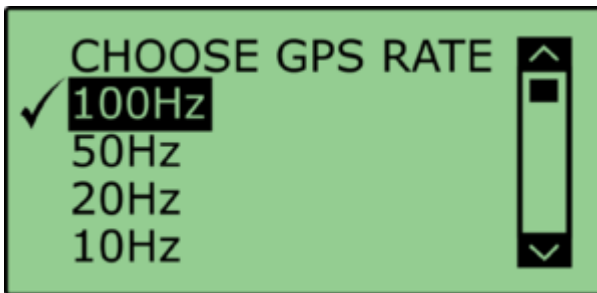

5. Select '**DYNAMICS**' and set the dynamic mode to '**NORMAL**', this Dynamics mode is best for ADAS tests, return to the '**VBOX**' setup menu.

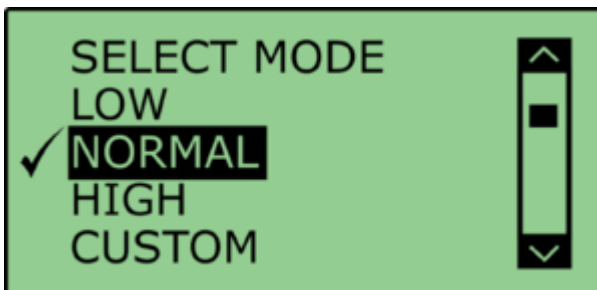

6. Select '**DGPS**' and set the DGPS mode to the same 2 cm mode that the Base Station is set to, return to the '**VBOX**' setup menu.

For further info on RTK modes see [RTK Configuration](#).

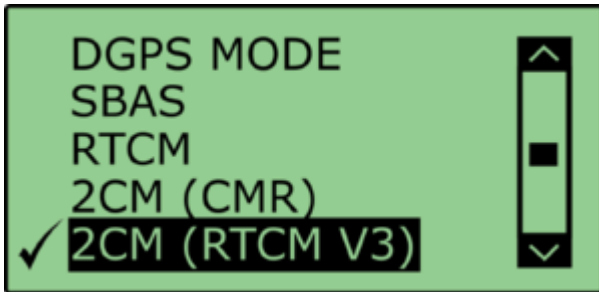

7. Select '**DGPS RS232 Rate**' and select the appropriate settings for your radios, return to the VBOX setup menu.

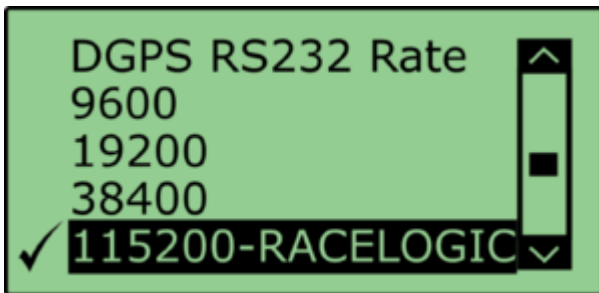

**Note:** To ensure that the VBOX receives the DGPS correction signal, the correct RS232 rate must be set. All Racelogic blue boxed radios use 115200 kbit/s, Satel grey boxed radios use either 19200 kbit/s or 38400 kbit/s.

8. Return to the main setup menu and select the '**ADAS**' option, then select '**MULTI. TARGET**' mode.

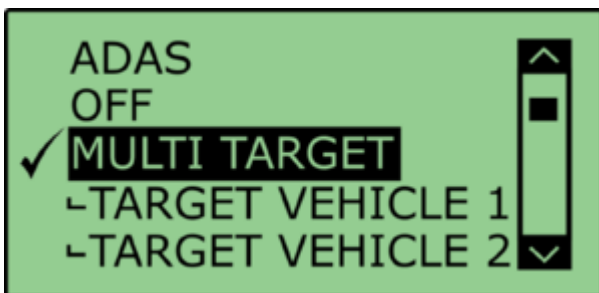

9. Select '**TARGET VEHICLE 1**' and return to the '**ADAS**' setup menu.

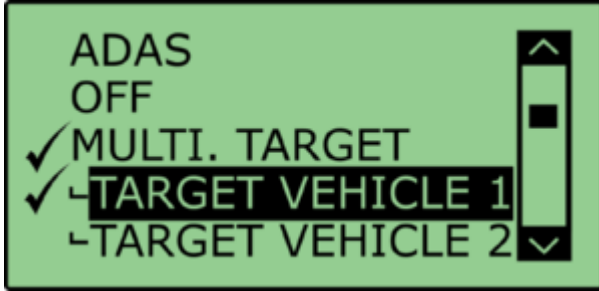

### Target Vehicle 2

1. Connect VBOX Manager to the VBOX in Target Vehicle 2.
2. Repeat steps 2 – 8 in section 'Target Vehicle 1' above.
3. Select '**TARGET VEHICLE 2**' and return to the '**ADAS**' setup menu.

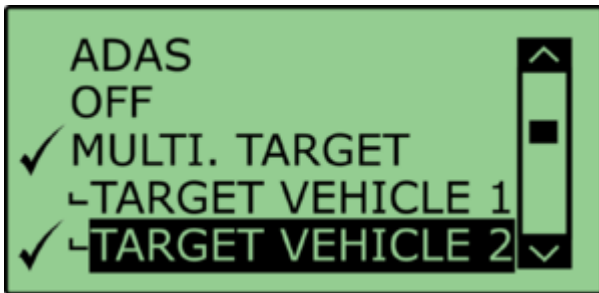

### Subject Vehicle

1. Connect VBOX Manager to the VBOX in the Subject Vehicle.
2. Repeat steps 2 – 8 in section 'Target Vehicle 1' above.



3. Select '**MULTI. TARGET**' mode and select '**SUBJECT VEHICLE**', return to the '**ADAS**' setup menu.

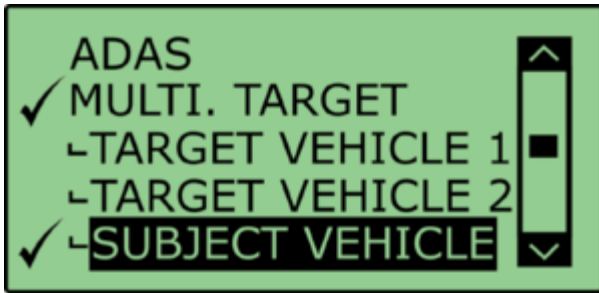

## ADAS Radio Link

For Multiple-Target mode, you must use radio modems programmed with different configuration scripts. It is not possible to use the normal ADAS link radios.

The Radios at each **TARGET VBOX** need to be set to **CLIENT** mode and paired to the singular ADAS radio at the subject vehicle.

The radio at the subject vehicle needs to be set to **SERVER** and **BROADCAST** mode.

1. Ensure the 2.4 GHz telemetry modems are connected as shown in [subject vehicle configuration](#) and [target vehicle configuration](#).
2. As 2.4 GHz transmissions are very direct, with a narrow beam width, care needs taking when mounting the antenna.  
Ensure they are:
  - On the highest part of the vehicle roof
  - Away from any nearby obstructions that could cause a potential blockage to the path of the signal
  - Mounted vertically to ensure maximum transmission power in the horizontal plane
  - Mounted at least 50 cm away from other radio antennas





When the 2.4 GHz modems are connected correctly the 'SER' light on the Subject VBOX will illuminate, indicating the reception of a serial data stream.



---

## RTK DGPS Configuration for Multi-Target

### Static Base

Please refer to the ['Base Station user guide'](#) for guidance on Base Station installation and setup.

### DGPS Modes

VBOX 3i and Base Station supports the use of three different RTK DGPS modes; each mode will provide 2 cm accurate solution.

Racelogic recommends the use of CMR or RTCMv3 as these modes have less radio bandwidth requirement, which should lead to more reliable RTK lock.



## RTK Status Indication

1. To confirm the Base Station telemetry units have been set up correctly the following should apply:

- The Tx LED on the Base Station telemetry unit should be flashing at 1 Hz.
- The Rx LEDs on the Subject and Target Vehicles telemetry units should be flashing at 1 Hz.

2. Confirm that both VBOX units are now in RTK 'Fixed' DGPS status, indicated by the following:



'DIFF' LED on the VBOX front panel is illuminated green.



A VBOX Tools live window set to Solution Type shows 'RTK FIXED'.

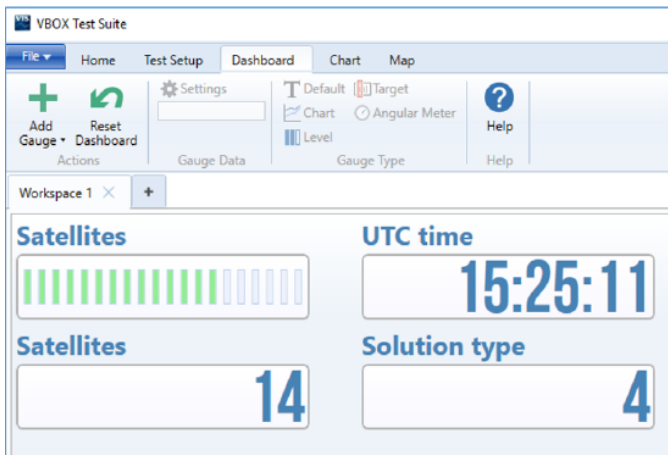

A VBOX Test Suite live Workspace window set to Solution type shows '4' (RTK fixed).



---

## Pre-Test Configuration

### Setting The Contact Points

After selecting the Subject Vehicle in either the multi or single target modes, the user can set the contact points by entering the '**CONTACT POINTS**' Menu.



In this menu, it is possible to define contact points for either the 'Subject Vehicle' or 'Target Vehicle'. You can manually configure up to 2 contact points by entering a numerical offset, or you can set up to 24 contact points by using a GPS antenna.

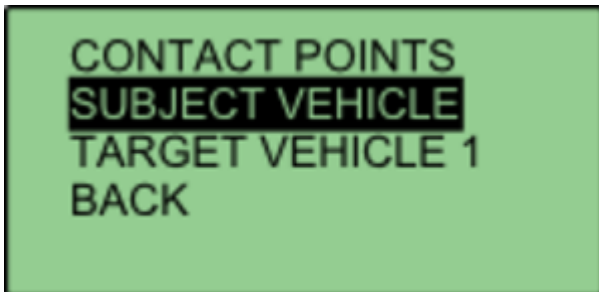

## Manually Entering Contact Points

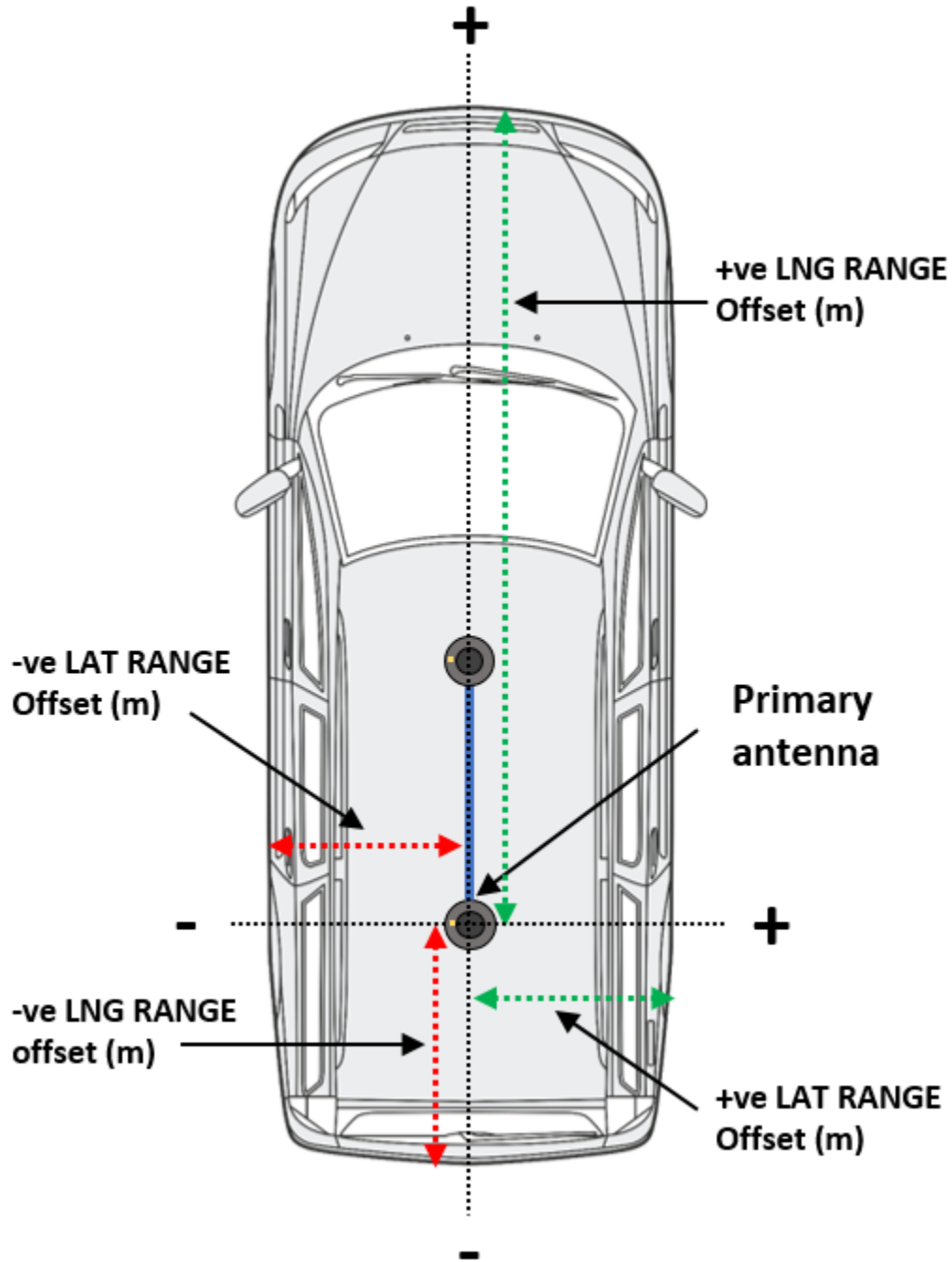

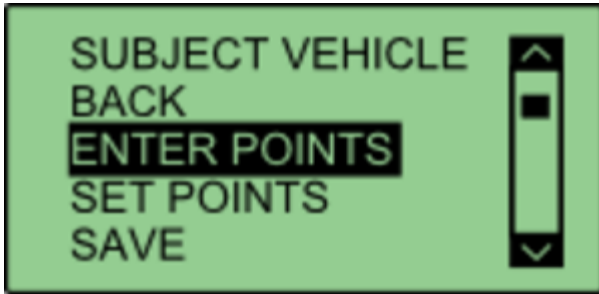

Select either '**SUBJECT VEHICLE**' or '**TARGET VEHICLE**' in the contact points menu.

Select '**ENTER POINTS**'.

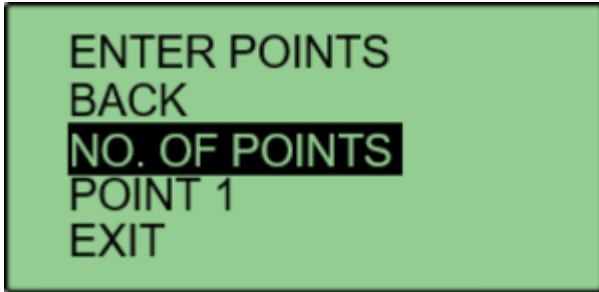

Select '**NO. OF POINTS**'.

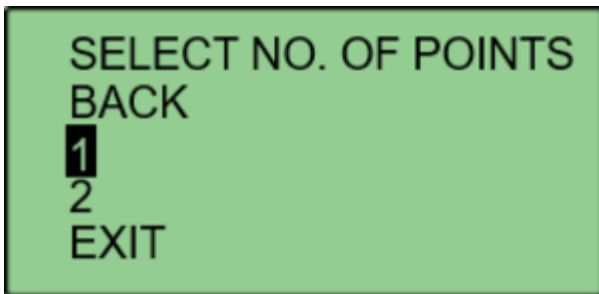

This menu allows the user to select whether 1 or 2 contact points are to be specified. The current number of selected points is highlighted with a tick next to the number. Selecting a different number will move that tick to that number. Select '**BACK**' once completed.

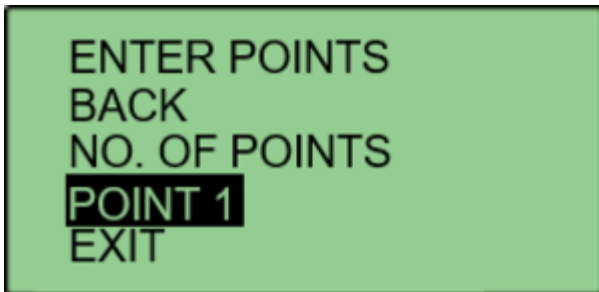

Select '**POINT 1**' to specify first contact point.



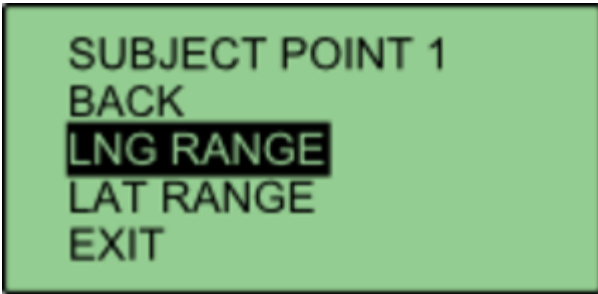

This menu allows the user to translate the **Primary** antenna point (or IMU if IMU integration is enabled) to a desired reference point on the vehicle. This is done by entering a numerical longitudinal ('LNG RANGE') and lateral ('LAT RANGE') offset value.



Selecting '**LNG RANGE**' allows the user to enter a longitudinal offset, with a forward offset being **POSITIVE** and a rearward offset being **NEGATIVE**. Pressing '**APPLY**' will store the value.



Selecting '**LAT RANGE**' allows the user to enter a lateral offset, with a rightwards offset being **POSITIVE** and a leftwards offset being **NEGATIVE**. Pressing '**APPLY**' will store the value. Select '**BACK**' to return to the previous menu.

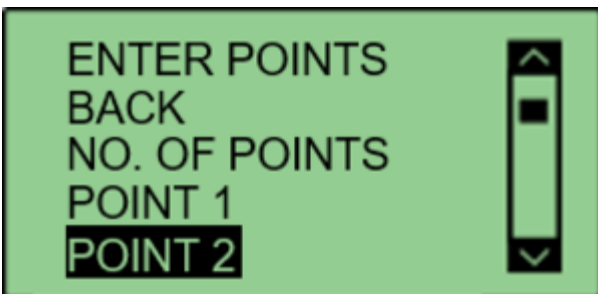

If the user selected 2 contact points in **NO. OF POINTS**, **POINT 2** will be displayed on the menu. Select '**POINT 2**' and repeat the above process.

Repeat this process to define the other vehicle.



## Setting Up To 24 Contact Points

Media, iframe, embed and object tags are not supported inside of a PDF.

First, connect a ground plane antenna to the VBOX.  
Select either '**SUBJECT VEHICLE**' or '**TARGET VEHICLE**' in the contact points menu. Select '**SET POINTS**'.

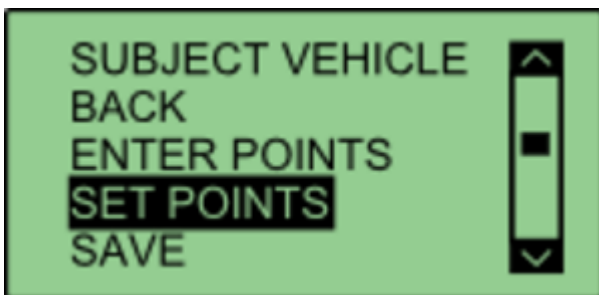

Using the survey pole, move the antenna to the desired contact point on the vehicle. Ensure there is a fixed RTK solution and select '**SET POINT**'.  
If successful, VBOX Manager will display '**POINT 1 SAVED**'.



If there is no RTK fix, the point will not be saved and VBOX Manager will display '**POINT 1 NOT SET, NOT RTK FIXED**'.

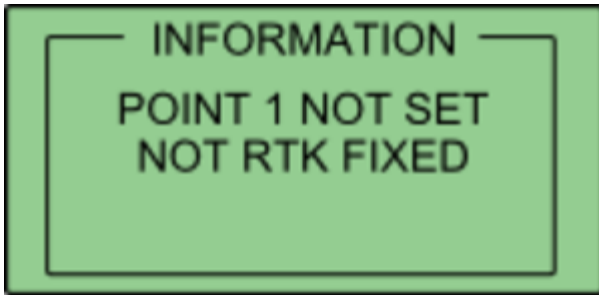

To set the next point, move the antenna to another desired point of contact and repeat the process. Repeat this process until all the desired points are set, or a limit of 24 is reached. Once all the desired points are set, move the antenna to the location of antenna A and select '**SET ANT A**'.

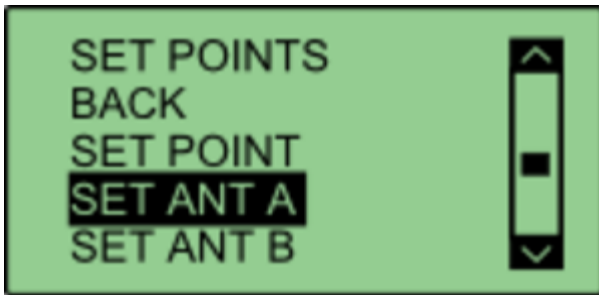

Then move the antenna to the location of Antenna B and select '**SET ANT B**'. This process can be repeated to define the other vehicle. If multiple points have been set on either vehicle, the calculated ADAS parameters (range, angle etc) will always reference the nearest surveyed point.

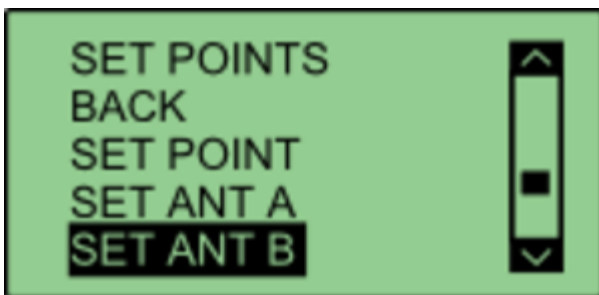



## Saving Vehicle Contact Points

After the required contact points have been surveyed, it is possible to save these points to the compact flash card by selecting **'SAVE'**.

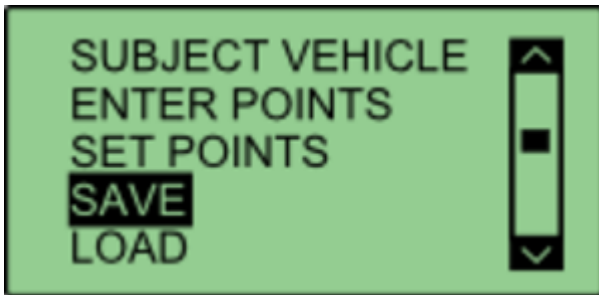

This allows the user to either overwrite a previously saved file, or create a new save file using the **'{CREATE NEW}'** option.

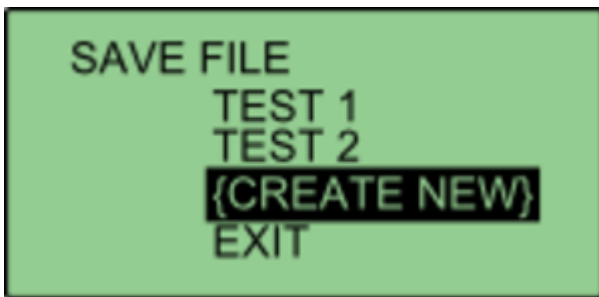

Selecting the **'{CREATE NEW}'** option will display an alpha numeric scroll wheel where the user can enter the desired file name.

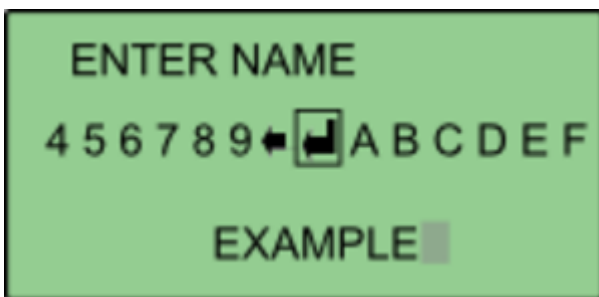

Once entered, VBOX Manager will display the '**SAVE SUCCESSFUL**' message.

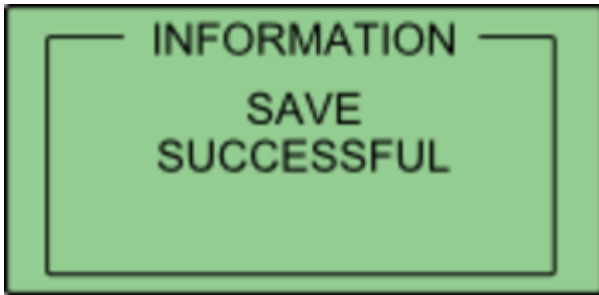

### Loading Vehicle Points

Select either '**SUBJECT VEHICLE**' or '**TARGET VEHICLE**' in the contact points menu. Then select '**LOAD**'.

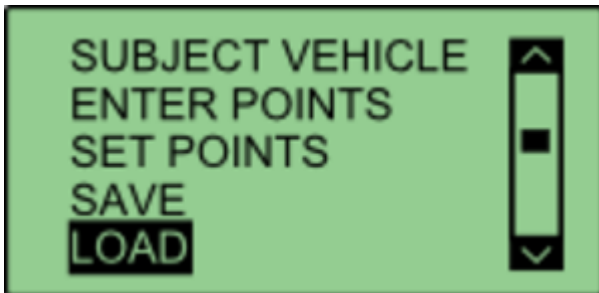

This will bring up a list of all previously saved files, which the user can select to load.



If successful, VBOX Manager will display '**LOAD SUCCESSFUL**'.

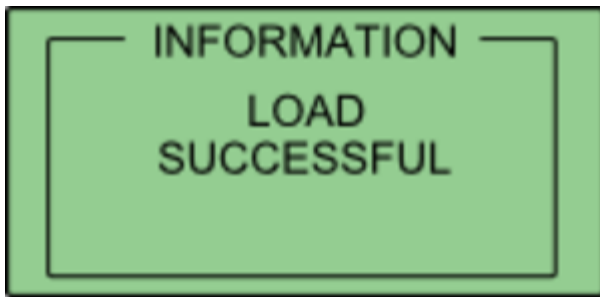

### Setting a reference line

A reference line is used to provide a very stable heading reference for the calculation of a noise free Lateral Difference Channel (LatDif-tg1) - see [parameter definitions](#) for more detail.

1. Under the '**MULTI. TARGET**' option within the '**ADAS**' menu, navigate to '**SUBJECT VEHICLE**' and select '**REF LINE**'.
2. Move the vehicle to the first nominated point along a straight line that runs perfectly parallel to the test track (a good method for this is to get the outside front and rear tyres perfectly aligned on a marked straight line).
3. Within the '**REF LINE**' menu, select '**SET PNT 1**'.

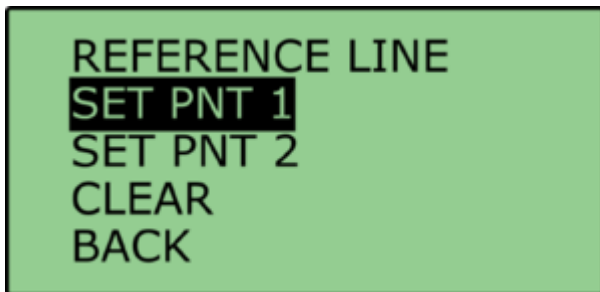

4. Move the vehicle to a distance at least 100 m along the straight line, ensuring that the car is re-aligned.



5. Select 'SET PNT 2'.

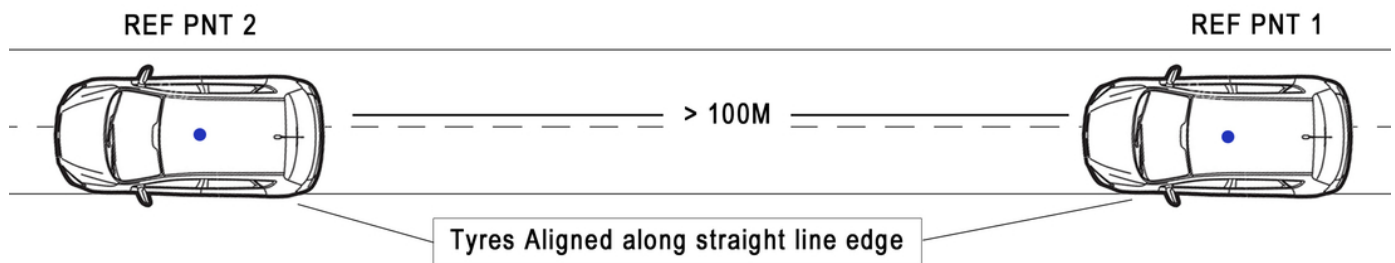
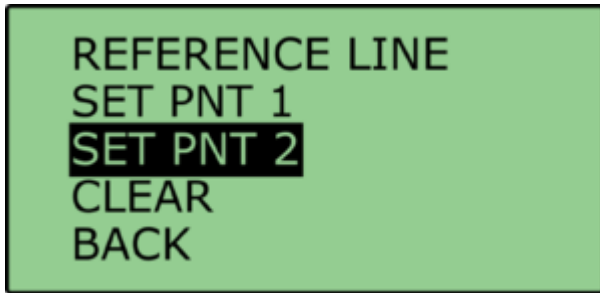

## Smoothing

If the box is set into twin antenna mode, the smoothing menu will not be present as the calculations will run off of the True heading provided by the twin antenna lock.

It is recommended that if user intends to set multiple points on the car, they enable the dual antenna.

There are two configurable variables linked to heading smoothing; 'Smoothing Distance' and 'Speed Threshold'. Due to the nature of the vehicle separation measurement and calculation process many channels are derived using the heading of the vehicle which can inherently be noisy. To overcome this heading can be smoothed with a dynamic smoothing routine.



## Smoothing Distance

The vehicle heading is normally calculated between the current and previous sample. Even with the stability of RTK position GPS position can vary by a few millimetres with respect to the original. When the travelled distance between subsequent samples is short (low speeds) this leads to a potential larger potential error in the calculated heading.

This smoothing routine allows the user to force a 'Smoothing Distance' over which heading is calculated. This is therefore dynamic, resulting in a variable number of samples used to determine the smoothing level on the heading; the lower the speed the more samples that are used. With 100 Hz logging and a smoothing distance of 1 m at 72 km/h, the heading is calculated over the previous 5 samples, whilst at 15 km/h the heading would be calculated over the previous 26 samples.

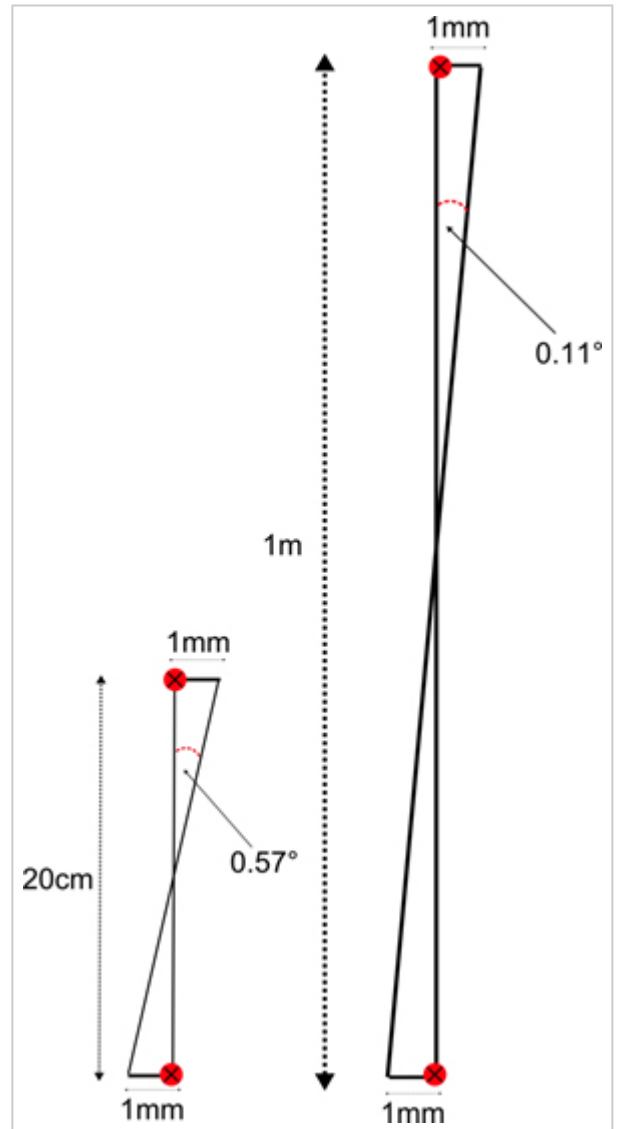

Vehicle travelling at 20 km/h in a straight path (not to scale)

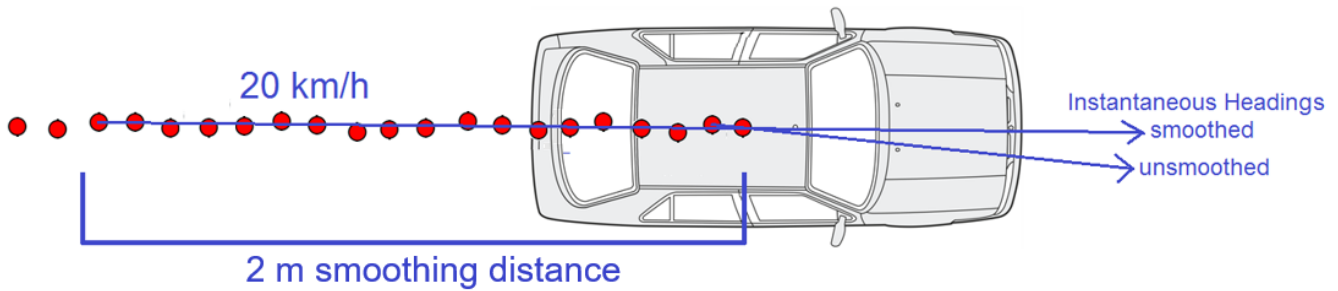

Above: Shows the improvement on vehicle heading from using smoothing distance

### Setting A Smoothing Distance

1. Using VBOX Manager, go to the '**ADAS**' menu and go to the '**MULTI. TARGET**' menu and select '**SUBJECT VEHICLE**'.

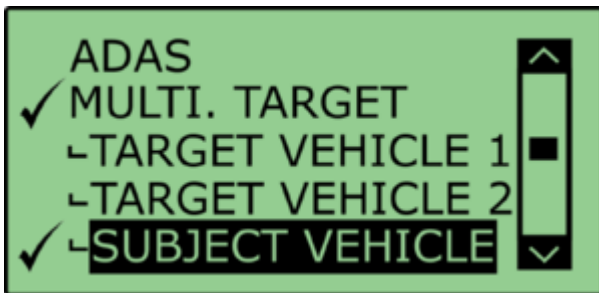

2. Select '**SMOOTHING**' from the '**SUBJECT VEHICLE**' menu.



3. Select '**SMOOTHING DIST**' and enter the smoothing option for the Subject Vehicle, from the options between 0.00 m and 2.00 m.

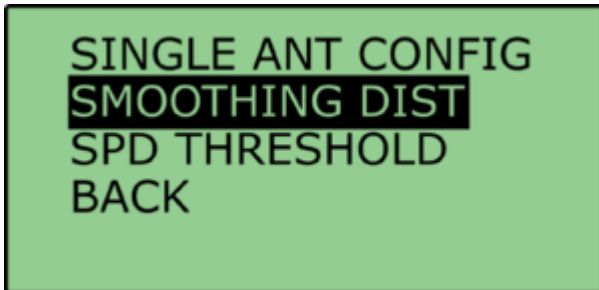

4. For typical Vehicle Separation applications we recommend a smoothing distance of 1 m.

### Speed Threshold

Due to the nature of how heading is calculated, even when Smoothing is applied at very low speeds and when the vehicle is stationary the heading channel can become very noisy and unusable, this in turn results in many of the Vehicle Separation channels becoming noisy at low speed and unusable when stationary. This is solved by fixing the heading below a configurable Speed Threshold.

1. To set the speed threshold repeat steps 1 and 2 above, then select '**SPD THRESHOLD**' and enter the speed threshold option for the Subject Vehicle.

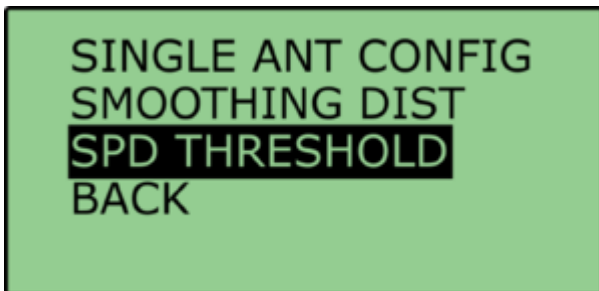

2. We recommend a Speed Threshold of 5 km/h.



## FCW - Single Target (Moving Base)

---

### Single Target Vehicle

This system consists of a VB3iSL-RTK in a Target vehicle and a VB3iSL-RTK in the Subject vehicle that calculates typical vehicle separation parameters, with respect to the Target vehicle.

High accuracy of the vehicle separation calculations is made possible by the use of a moving base solution.

Moving Base solution removes the need for a fixed Base Station to obtain accurate range between vehicles, thereby allowing vehicle separation testing to be carried out in real world environments and without the restrictions of Base Station radio range.

The Target VBOX (tracked vehicle) will also log the normal GPS data to a .vbo file, so that the files from each VBOX can be compared in the VBOX Tools Graph screen or VBOX Test Suite Chart screen. This is useful to see the relative positions.

Configuration of the VBOX's is done through VBOX Manager (RLVBFMAN).

---

### Hardware configuration

Single Vehicle Target testing requires the installation of two VBOX ADAS systems, one in the Subject Vehicle and one in the Target Vehicle. The following diagrams show the recommended hardware configuration for each vehicle. The items greyed out are not essential but many customers may find them beneficial.

Connection between the VB3i and computer should be made via USB or Bluetooth to ensure optimum performance.

**Please ensure that all vehicle antennas are correctly positioned and connected.**





# Subject Vehicle

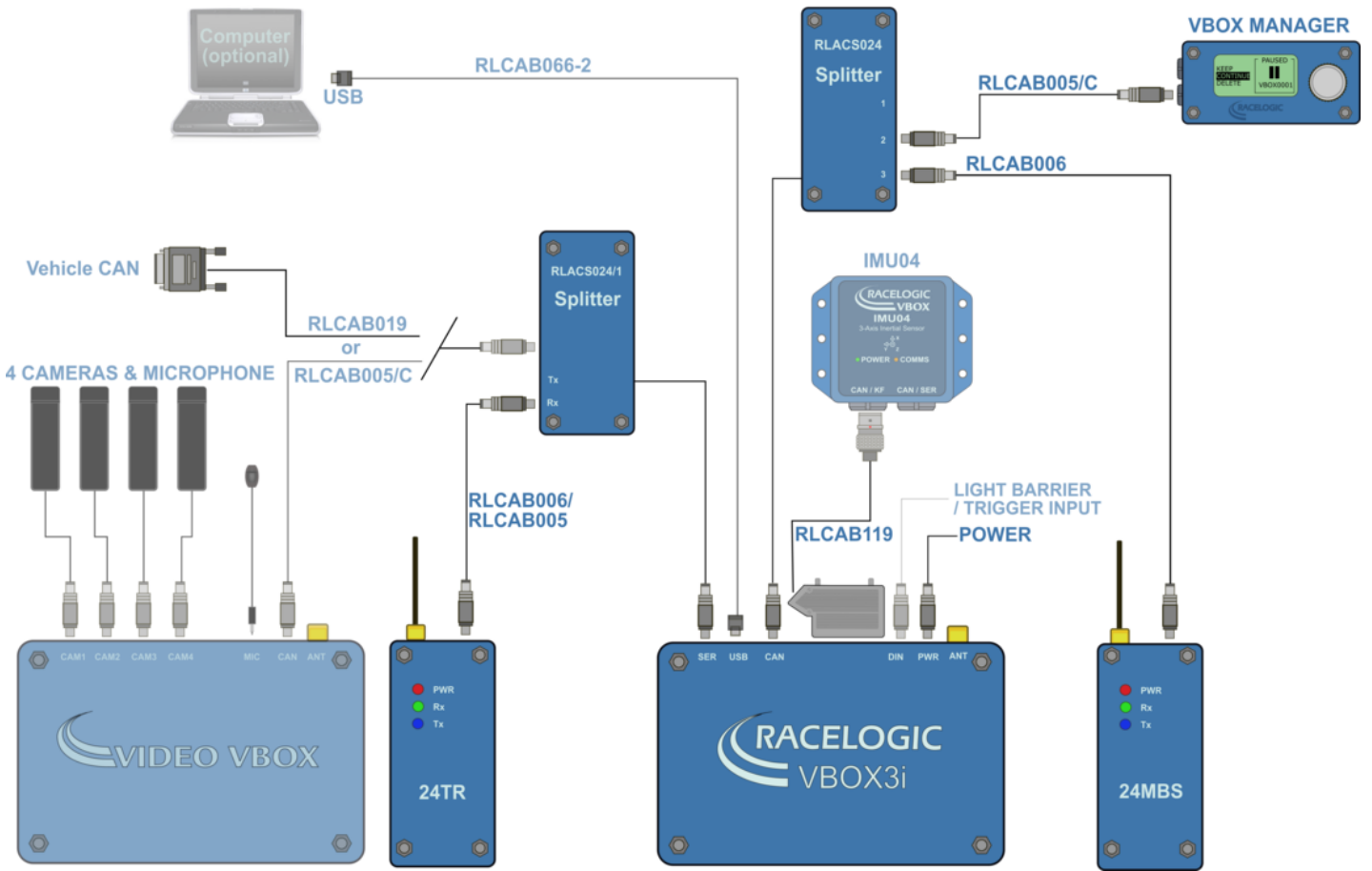

# Target Vehicle

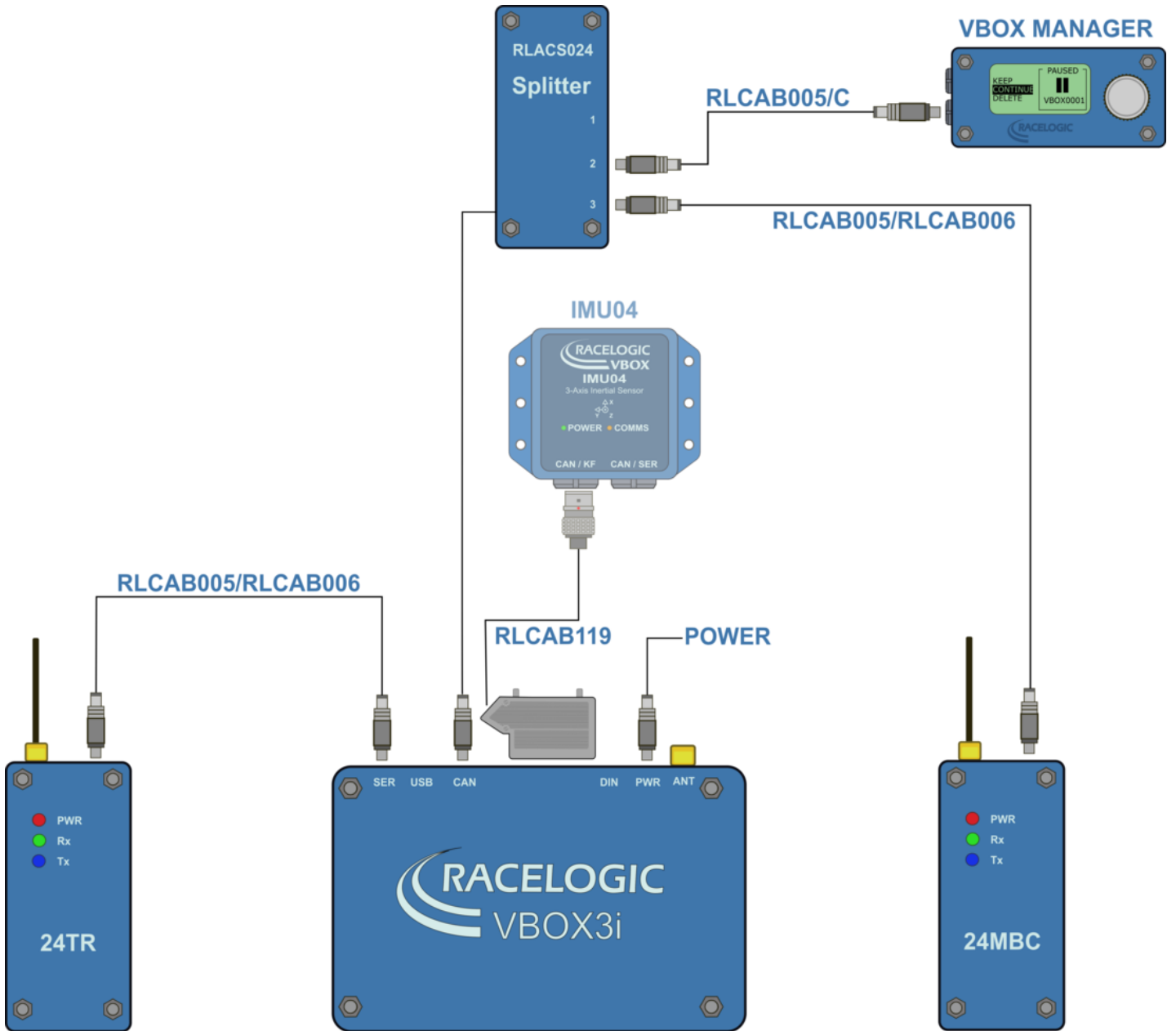

---

## VBOX Configuration

### Target Vehicle

This guide assumes the use of a moving base solution.

1. Connect the VBOX Manager to the VBOX in the Target Vehicle.
2. Enter the setup menu of the VBOX Manager.
3. Select the '**VBOX**' option.
4. Select '**LOG RATE**' and set the rate to '**100 Hz**', then select '**BACK**' to return to the '**VBOX**' setup menu.

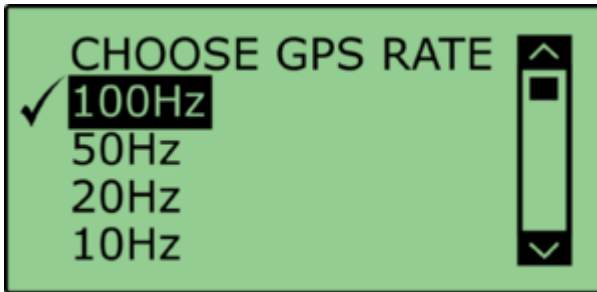

5. Select '**DYNAMICS**' and set the dynamic mode to '**NORMAL**', this Dynamics mode is best for ADAS tests, return to the '**VBOX**' setup menu.

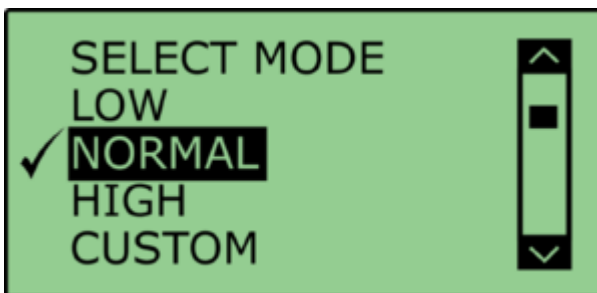

6. Select '**DGPS**' and set the DGPS mode to '**MB Rover**', return to the '**VBOX**' setup menu.

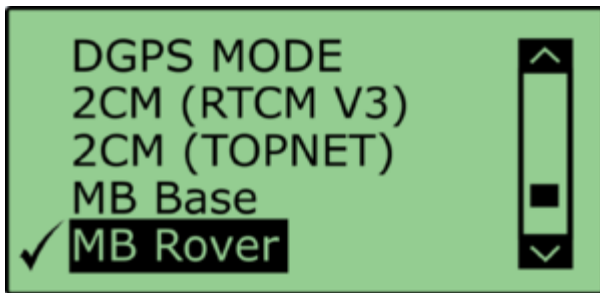

7. Select '**DGPS RS232 Rate**' and ensure that '**115200**' is selected, return to the '**VBOX**' setup menu.

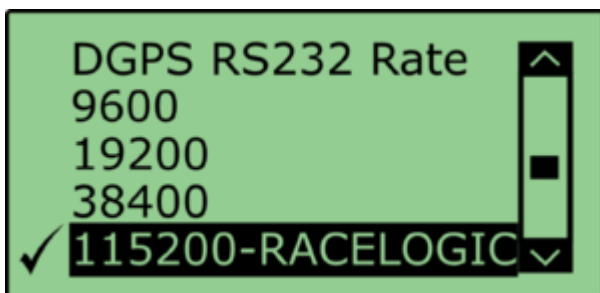

**Note:** To ensure that the VBOX receives the DGPS correction signal, the correct RS232 rate must be set. All Racelogic blue boxed radios use 115200 kbit/s, Satel grey boxed radios use either 19200 kbit/s or 38400 kbit/s.

8. Return to the main setup menu and select the '**ADAS**' option, then select '**SINGLE TARGET**' mode.

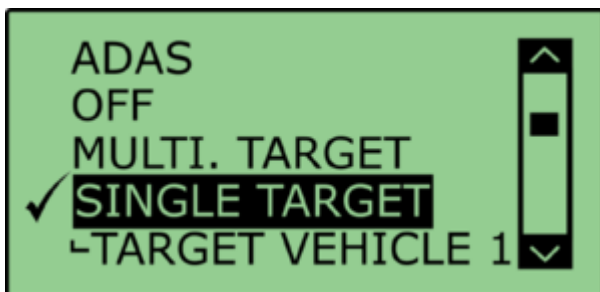

9. Select '**TARGET VEHICLE 1**' and return to the '**ADAS**' setup menu.

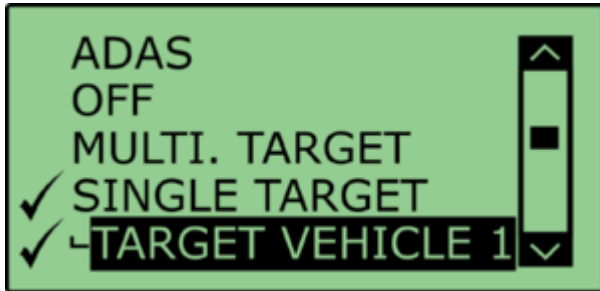

### Subject Vehicle

1. Connect VBOX Manager to the VBOX in the Subject Vehicle.
2. Repeat steps 2 – 5 in section 'Target Vehicle' above.
3. Select '**DGPS**' and set the DGPS mode to '**MB Base**', return to the '**VBOX**' setup menu.

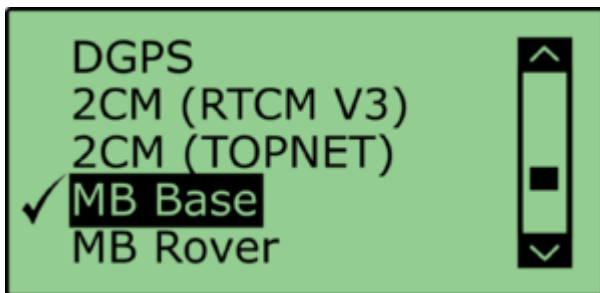

4. Select '**DGPS RS232 RATE**' and ensure that '**115200**' is selected, return to the '**VBOX**' setup menu.

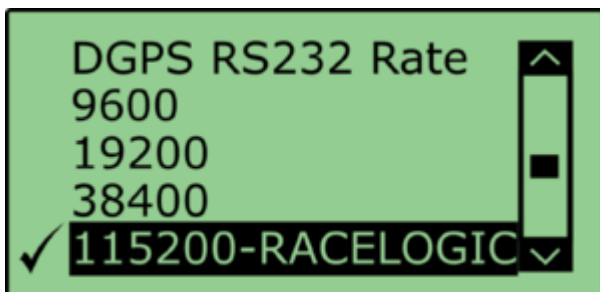

5. Select '**SINGLE TARGET**' mode and select '**SUBJECT VEHICLE**', return to the '**ADAS**' setup menu.

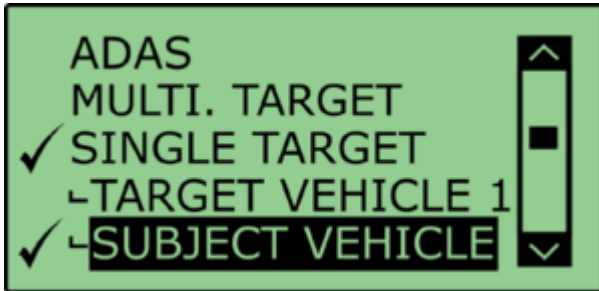

## ADAS Radio Link

1. Ensure the 2.4 GHz telemetry modems are connected as shown in [subject vehicle configuration](#) and [target vehicle configuration](#).
2. As 2.4 GHz transmissions are very direct, with a narrow beam width, care needs taking when mounting the antenna; ensure they are:
  - On the highest part of the vehicle roof
  - Away from any nearby obstructions that could cause a potential blockage to the path of the signal
  - Mounted vertically to ensure maximum transmission power in the horizontal plane
  - Mounted at least 50 cm away from other Radio antennas

When the 2.4 GHz modems are connected correctly the 'SER' light on the SUBJECT VBOX will illuminate, indicating the reception of a serial data stream.



---

## Pre-Test Configuration

### Setting the Contact points

After selecting the Subject Vehicle in either the multi or single target modes, the user can set the contact points by entering the '**CONTACT POINTS**' Menu.



In this menu, it is possible to define contact points for either the 'Subject Vehicle' or 'Target Vehicle'. You can manually configure up to 2 contact points by entering a numerical offset, or you can set up to 24 contact points by using a GPS antenna.

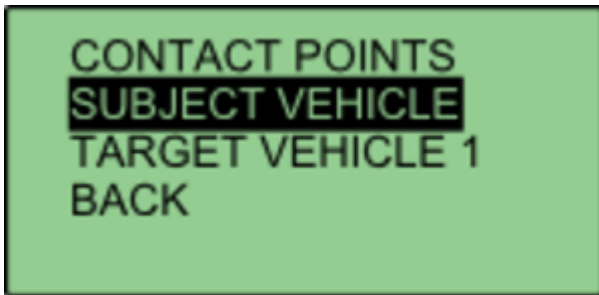

## Manually Entering Contact Points

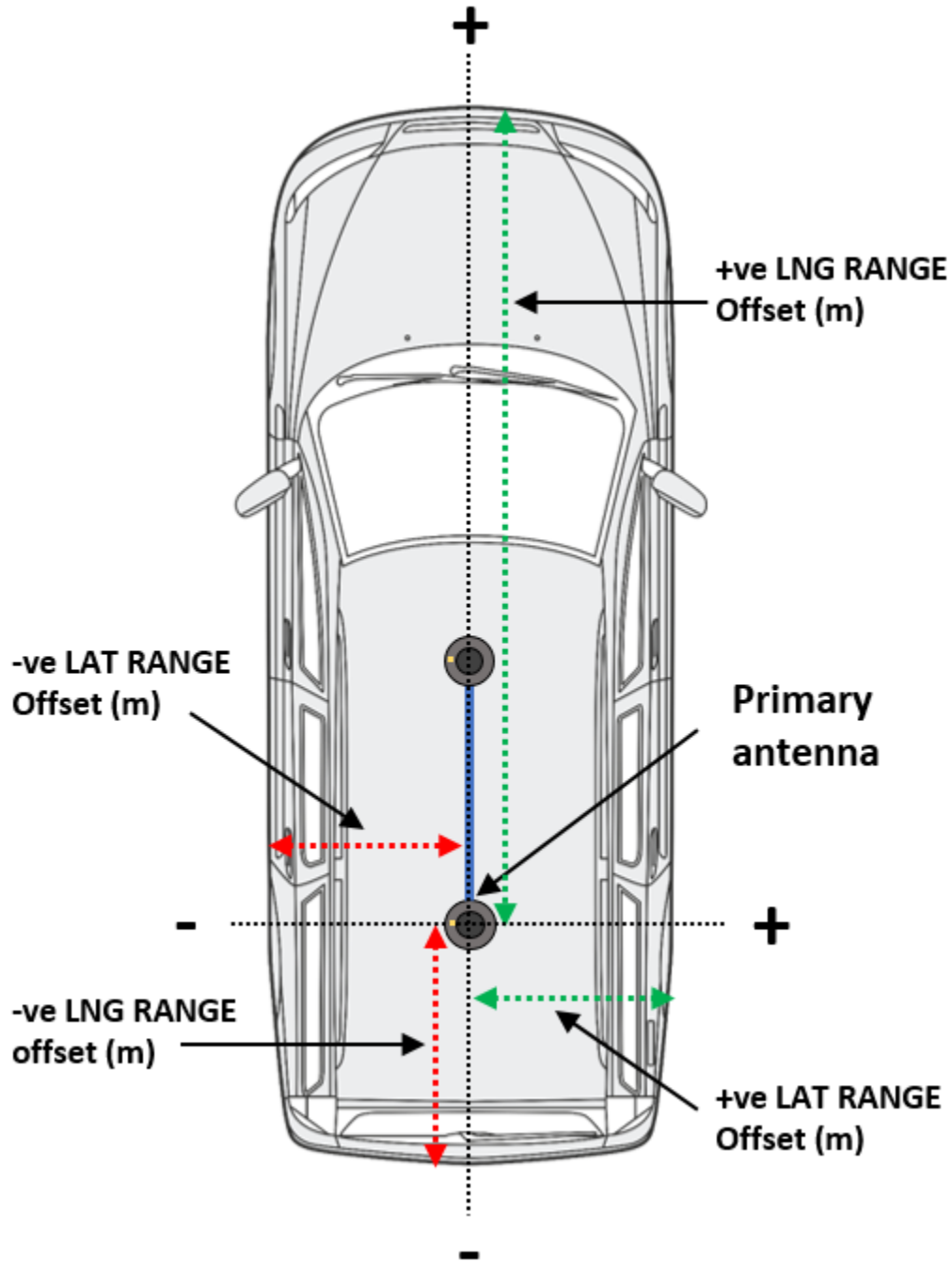



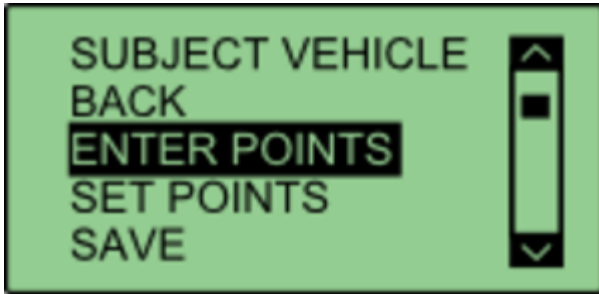

Select either '**SUBJECT VEHICLE**' or '**TARGET VEHICLE**' in the contact points menu.

Select '**ENTER POINTS**'.

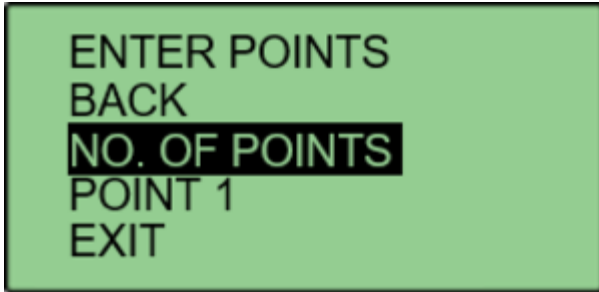

Select '**NO. OF POINTS**'.

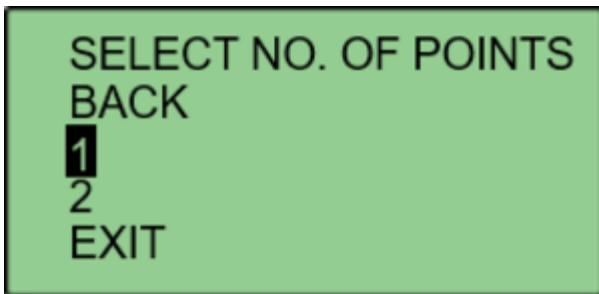

This menu allows the user to select whether 1 or 2 contact points are to be specified. The current number of selected points is highlighted with a tick next to the number. Selecting a different number will move that tick to that number. Select '**BACK**' once completed.

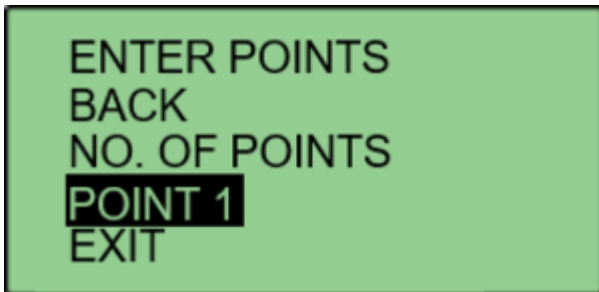

Select '**POINT 1**' to specify first contact point.



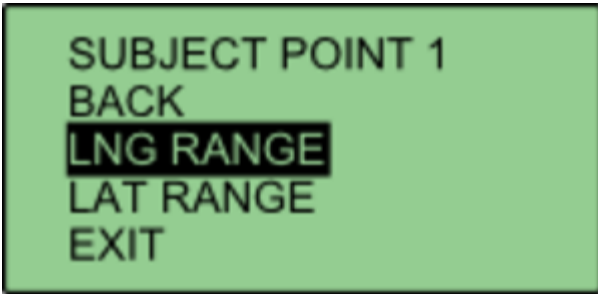

This menu allows the user to translate the **Primary** antenna point (or IMU if IMU integration is enabled) to a desired reference point on the vehicle. This is done by entering a numerical longitudinal ('LNG RANGE') and lateral ('LAT RANGE') offset value.



Selecting '**LNG RANGE**' allows the user to enter a longitudinal offset, with a forward offset being **POSITIVE** and a rearward offset being **NEGATIVE**. Pressing '**APPLY**' will store the value.



Selecting '**LAT RANGE**' allows the user to enter a lateral offset, with a rightwards offset being **POSITIVE** and a leftwards offset being **NEGATIVE**. Pressing '**APPLY**' will store the value. Select '**BACK**' to return to the previous menu.

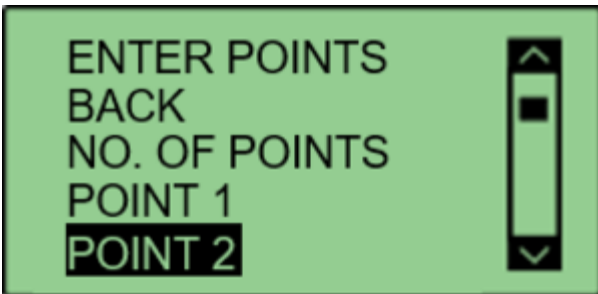

If the user selected 2 contact points in **NO. OF POINTS**, **POINT 2** will be displayed on the menu. Select '**POINT 2**' and repeat the above process.

Repeat this process to define the other vehicle.



## Setting Up To 24 Contact Points

Media, iframe, embed and object tags are not supported inside of a PDF.

First, connect a ground plane antenna to the VBOX.

Select either '**SUBJECT VEHICLE**' or '**TARGET VEHICLE**' in the contact points menu. Select '**SET POINTS**'.

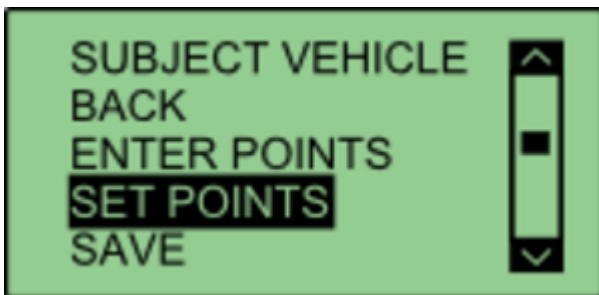

Using the survey pole, move the antenna to the desired contact point on the vehicle. Ensure there is a fixed RTK solution and select '**SET POINT**'.

If successful, VBOX Manager will display '**POINT 1 SAVED**'.



If there is no RTK fix, the point will not be saved and VBOX Manager will display '**POINT 1 NOT SET, NOT RTK FIXED**'.

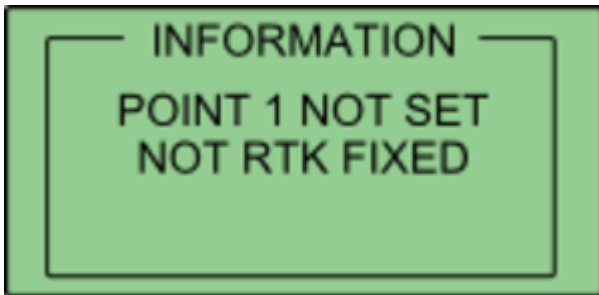

To set the next point, move the antenna to another desired point of contact and repeat the process. Repeat this process until all the desired points are set, or a limit of 24 is reached. Once all the desired points are set, move the antenna to the location of antenna A and select '**SET ANT A**'.

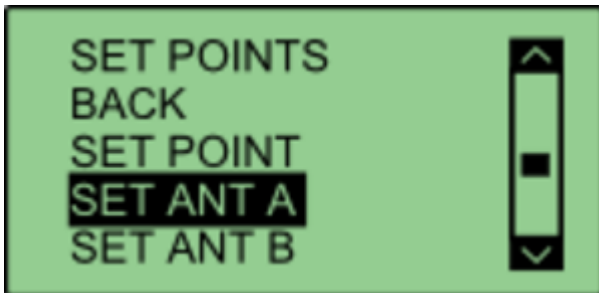

Then move the antenna to the location of Antenna B and select '**SET ANT B**'. This process can be repeated to define the other vehicle. If multiple points have been set on either vehicle, the calculated ADAS parameters (range, angle etc) will always reference the nearest surveyed point.

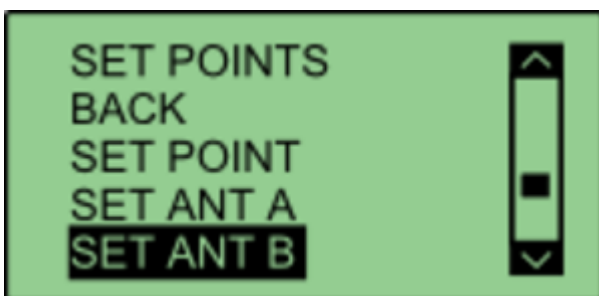

## Saving Vehicle Contact Points

After the required contact points have been surveyed, it is possible to save these points to the compact flash card by selecting **'SAVE'**.

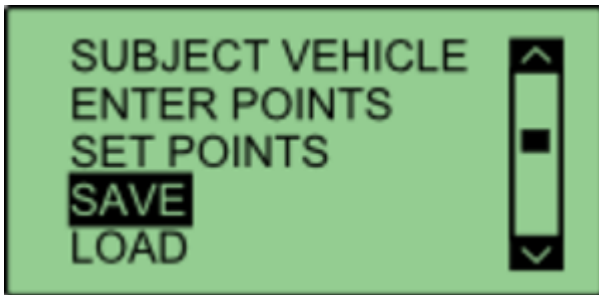

This allows the user to either overwrite a previously saved file, or create a new save file using the **'{CREATE NEW}'** option.

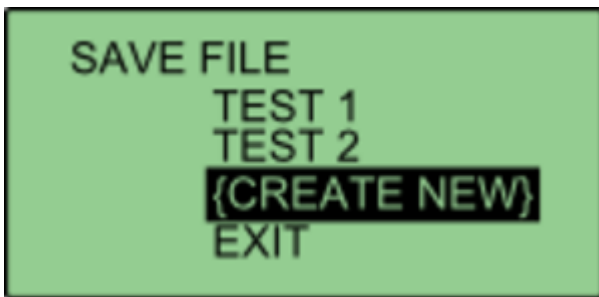

Selecting the **'{CREATE NEW}'** option will display an alpha numeric scroll wheel where the user can enter the desired file name.

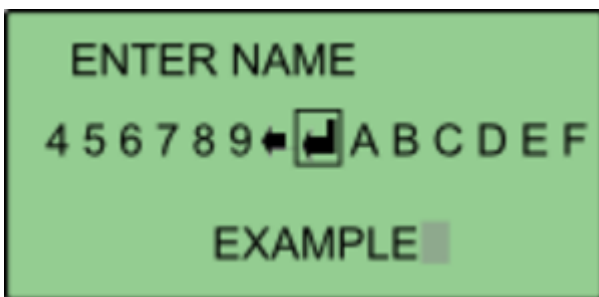

Once entered, VBOX Manager will display the '**SAVE SUCCESSFUL**' message.

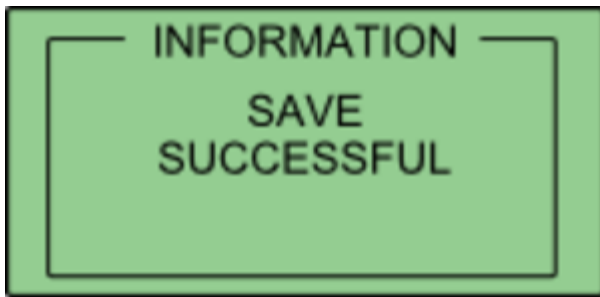

### Loading Vehicle Points

Select either '**SUBJECT VEHICLE**' or '**TARGET VEHICLE**' in the contact points menu. Then select '**LOAD**'.

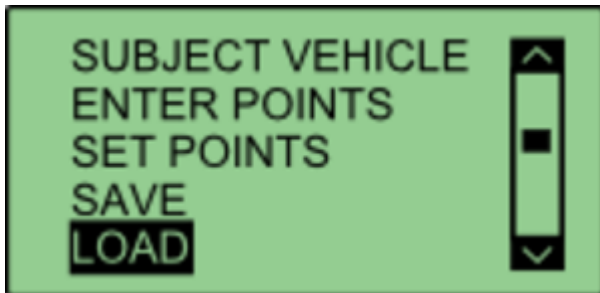

This will bring up a list of all previously saved files, which the user can select to load.



If successful, VBOX Manager will display '**LOAD SUCCESSFUL**'.

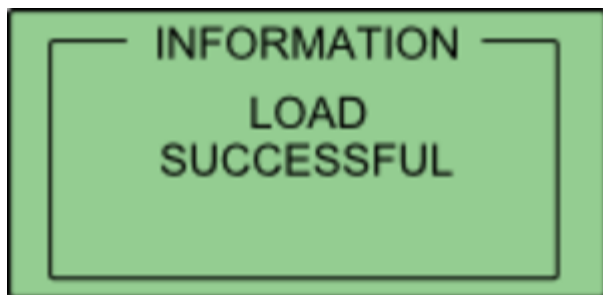

## Smoothing

If the box is set into twin antenna mode, the smoothing menu will not be present as the calculations will run off of the True heading provided by the twin antenna lock.

It is recommended that if user intends to set multiple points on the car, they enable the dual antenna.

There are two configurable variables linked to heading smoothing; 'Smoothing Distance' and 'Speed Threshold'. Due to the nature of the vehicle separation measurement and calculation process many channels are derived using the heading of the vehicle which can inherently be noisy. To overcome this heading can be smoothed with a dynamic smoothing routine.



## Smoothing Distance

The vehicle heading is normally calculated between the current and previous sample. Even with the stability of RTK position GPS position can vary by a few millimetres with respect to the original. When the travelled distance between subsequent samples is short (low speeds) this leads to a potential larger potential error in the calculated heading.

This smoothing routine allows the user to force a 'Smoothing Distance' over which heading is calculated. This is therefore dynamic, resulting in a variable number of samples used to determine the smoothing level on the heading; the lower the speed the more samples that are used. With 100 Hz logging and a smoothing distance of 1 m at 72 km/h, the heading is calculated over the previous 5 samples, whilst at 15 km/h the heading would be calculated over the previous 26 samples.

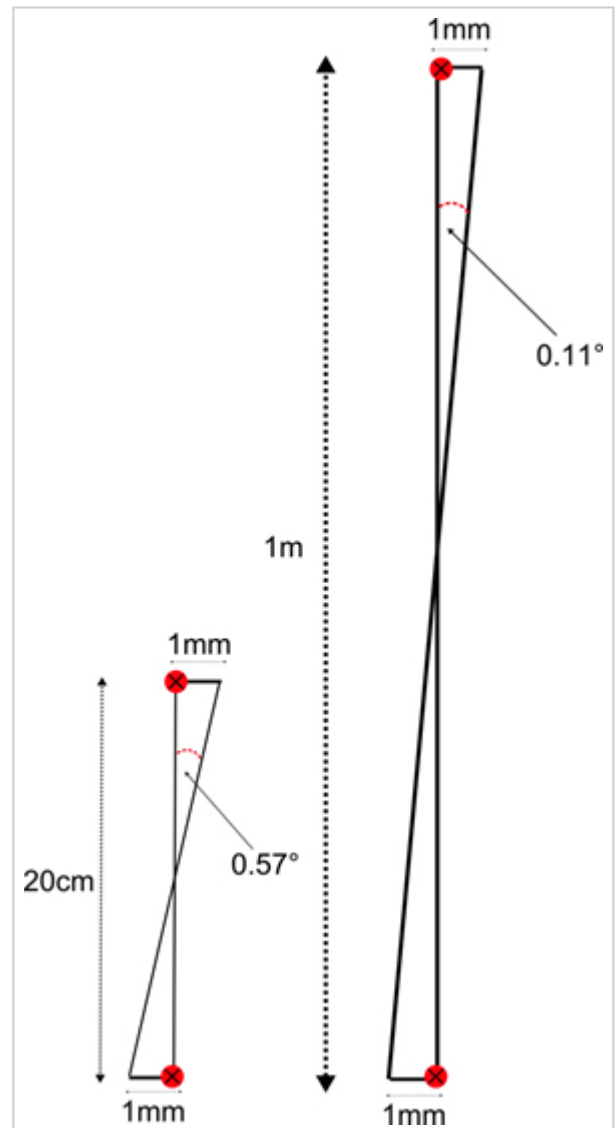



Vehicle travelling at 20 km/h in a straight path (not to scale)

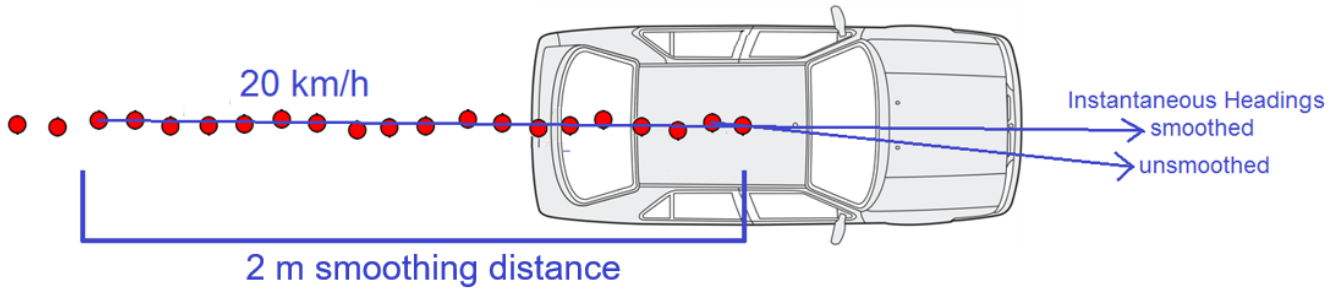

Above: Shows the improvement on vehicle heading from using smoothing distance

### Setting A Smoothing Distance

1. Using VBOX Manager, go to the '**ADAS**' menu and go to the '**SINGLE TARGET**' menu and select '**SUBJECT VEHICLE**'.

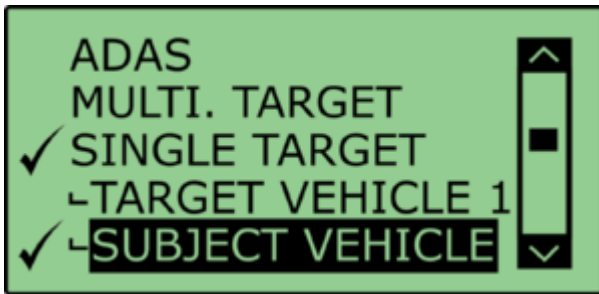

2. Select '**SMOOTHING**' from the '**SUBJECT VEHICLE**' menu.



3. Select '**SMOOTHING DIST**' and enter the smoothing option for the Subject Vehicle, from the options between 0.00 m and 2.00 m.

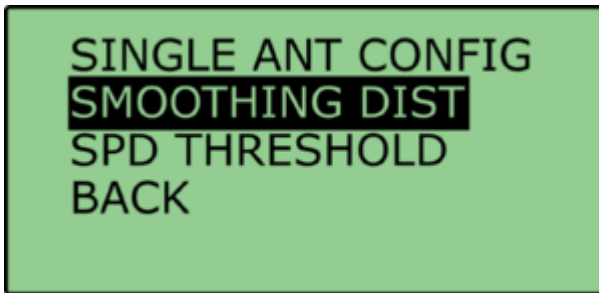

4. For typical Vehicle Separation applications we recommend a smoothing distance of 1 m.

### Speed Threshold

Due to the nature of how heading is calculated, even when Smoothing is applied at very low speeds and when the vehicle is stationary the heading channel can become very noisy and unusable, this in turn results in many of the Vehicle Separation channels becoming noisy at low speed and unusable when stationary. This is solved by fixing the heading below a configurable Speed Threshold.

1. To set the speed threshold repeat steps 1 and 2 above, then select '**SPD THRESHOLD**' and enter the speed threshold option for the Subject Vehicle.

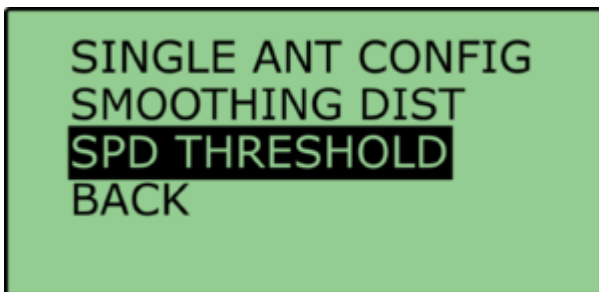

2. We recommend a Speed Threshold of 5 km/h.



---

## Single Target 'Duplex Mode'

In this mode all of the Vehicle Separation parameters are also calculated at the Target Vehicle. This is facilitated by creating a 'Duplex' ADAS radio link between the Subject and Target Vehicle.

This is **NOT** possible in 'Multi Target' mode.

The channels calculated in the Target Vehicle are the same as the channels calculated by the VBOX in the Subject Vehicle. They are not new channels calculated in opposite respect; Target to Subject.

### Duplex Mode Benefits

All vehicle separation channels can be viewed live by the driver of the Target Vehicle.

- A Throttle and Braking robot can be connected to the Target VBOX CAN Bus so that the separation and speed of the Target Vehicle can be controlled more consistently.
- The logging of the Target Vehicle VBOX can be automatically synchronised to the Subject Vehicle logging.



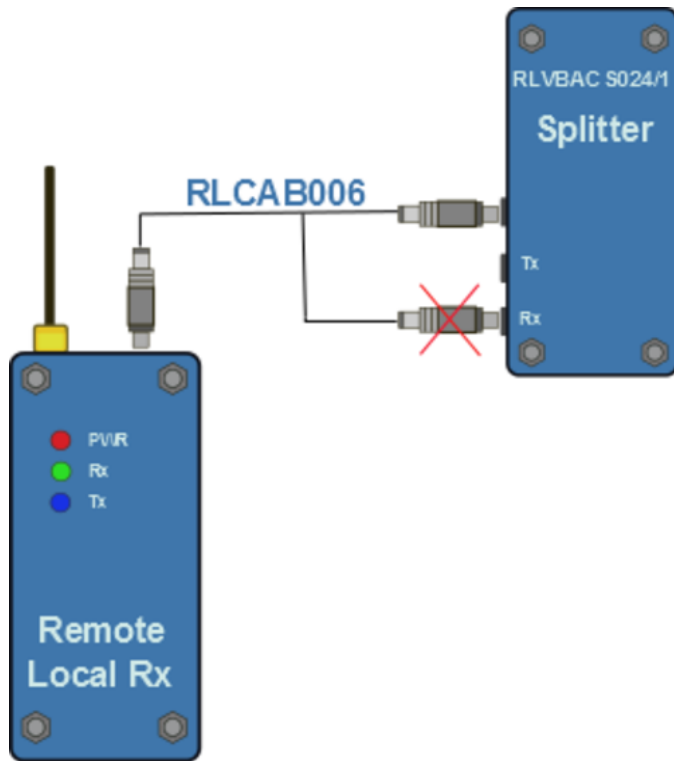

## Hardware configuration

The hardware at the Subject Vehicle should be connected as per the [Subject Vehicle separation diagram](#), except from the following important change.

The ADAS link radio needs to be unplugged from the 'RX' socket and plugged into the unlabelled socket on the RLVBACS024/1 splitter.

This will allow a full Duplex link to exist between the Subject and Target VBOX's.

You should now see that the RX and TX lights of both ADAS radios will now be flashing.

## Pre-Test Configuration

The Duplex Radio link allows any configurations that are set in the Subject VBOX to be instantly communicated to the Target VBOX, so that both boxes produce the same values for all Veh Sep parameters.

The Duplex Radio link allows any configurations that are set in the Subject VBOX to be instantly communicated to the Target VBOX, so that both boxes produce the same values for all Veh Sep parameters.

On power up and during the first communication between each VBOX there will also be a synchronisation of configurations between each VBOX.



## 'SYNC TARGET'

When in Duplex mode (Single target only), the target VBOX has to understand which contact points have been set in the subject vehicle. To do this, the user must have a valid radio link between the two VBOXs and then select the '**SYNC TARGET**' option under the '**SUBJECT VEHICLE**' menu.

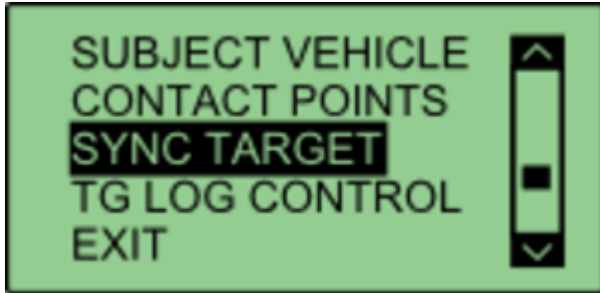

Selecting this option will transmit all the subject vehicles settings to the target vehicle, allowing live data to be displayed in the target vehicle.

## Logging

It is possible to synchronise the logging of both VBOX's in this Duplex mode.

To make this possible:

- Set the logging mode in both VBOX's to '**LOG CONTINUOUSLY**'.
- Connect VBOX Manager to the Subject vehicle VBOX.
- Then use VBOX Manager to start and stop the file logging.

The logging of data at the Target vehicle will stop and start in synch with the VBOX Manager control.

*Note: If you stop the logging with the 'LOG' button on the Target VBOX then you will overwrite this auto-logging control.*

## Moving Base

It is possible to use Moving Base mode when in Duplex mode. However the extra amount of 2.4 GHz radio in close proximity can degrade the ADAS radio link, which can result in more dropouts and reduced range.



## FCW - Single Target (Static Base)

---

### Single Target Vehicle

This system consists of a VB3iSL-RTK in a Target Vehicle and a VB3iSL-RTK in the Subject Vehicle that calculates typical vehicle separation parameters, with respect to the Target Vehicle.

High accuracy of the vehicle separation calculations is made possible by the use of a Static Base Station.

The Target VBOX (tracked vehicle) will also log the normal GPS data to a .vbo file, so that the files from each VBOX can be compared in the VBOX Tools Graph screen or VBOX Test Suite Chart screen. This is useful to see the relative positions.

Configuration of the VBOX's is done through VBOX Manager (RLVBFMAN).

---

### Hardware configuration

Single Vehicle Target testing requires the installation of two VBOX ADAS systems, one in the Subject Vehicle and one in the Target Vehicle. The following diagrams show the recommended hardware configuration for each vehicle. The items greyed out are not essential but many customers may find them beneficial.

Connection between the VB3i and computer should be made via USB or Bluetooth to ensure optimum performance.

**Please ensure that all vehicle antennas are correctly positioned and connected.**



# Subject Vehicle

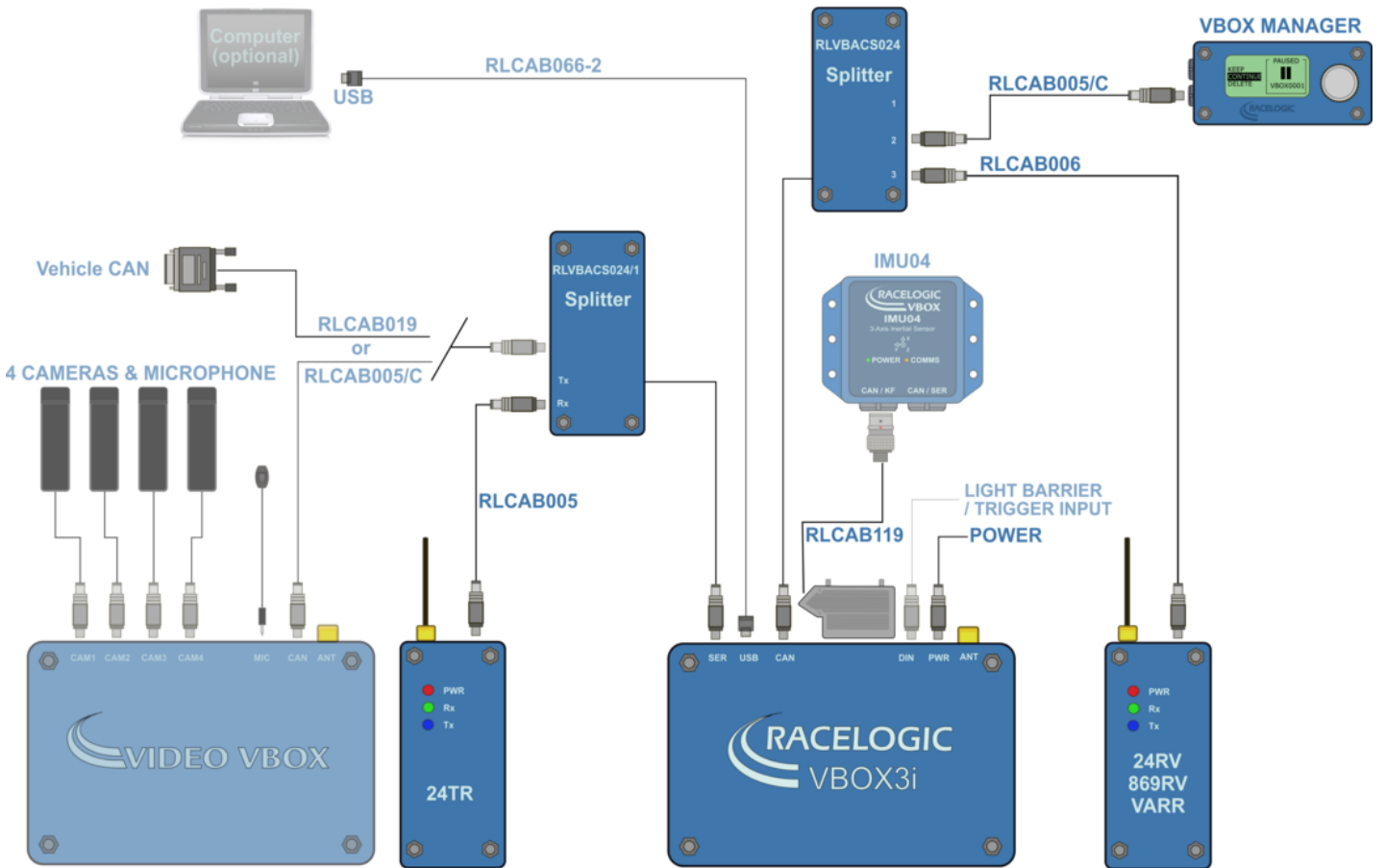

# Target Vehicle

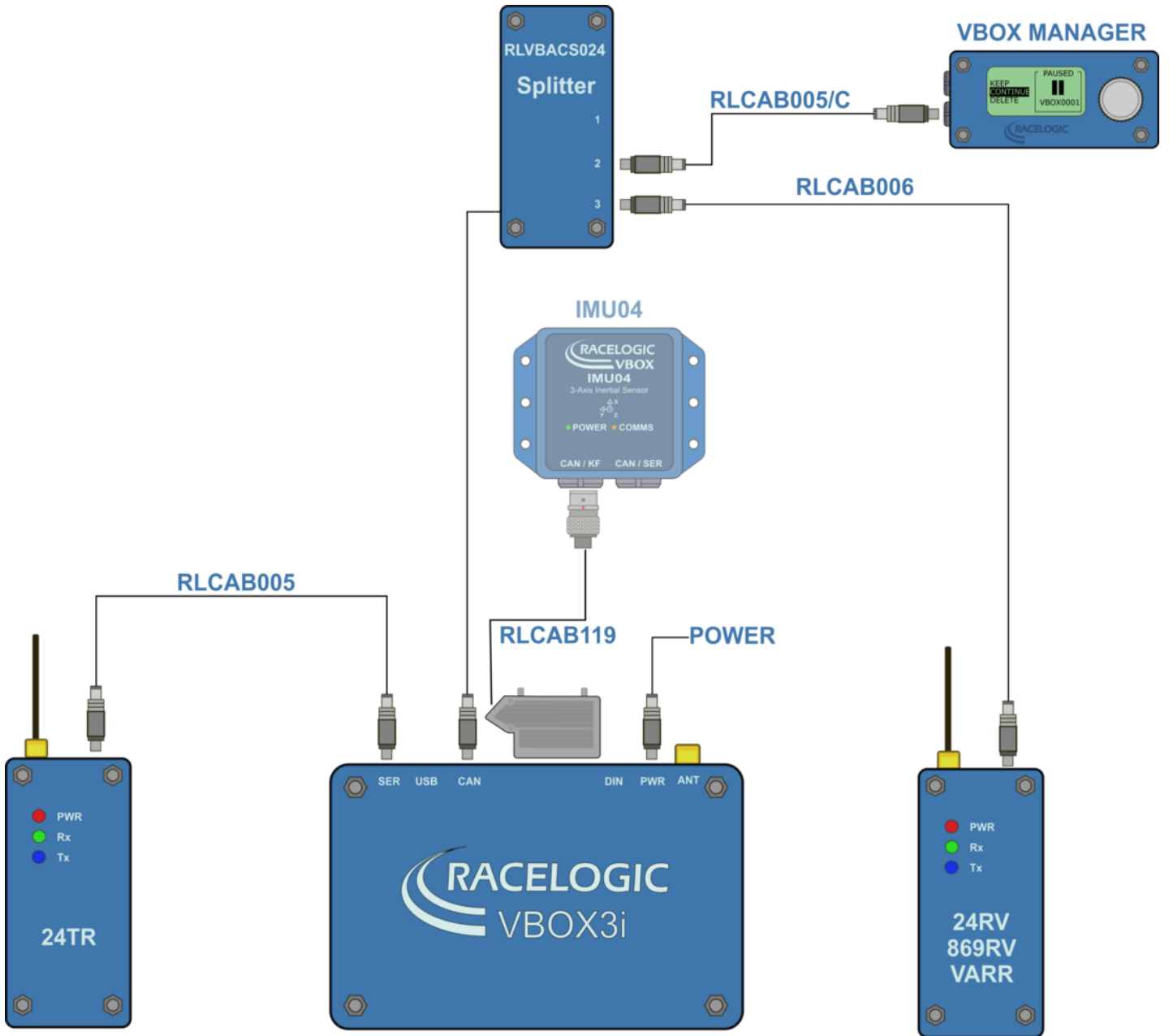



---

## VBOX Configuration

### Target Vehicle

This guide assumes the use of a Base Station.

1. Connect VBOX Manager to the VBOX in Target Vehicle.
2. Enter the setup menu of VBOX Manager.
3. Select the '**VBOX**' option.
4. Select '**LOG RATE**' and set the rate to '**100 Hz**', then select '**BACK**' to return to the '**VBOX**' setup menu.

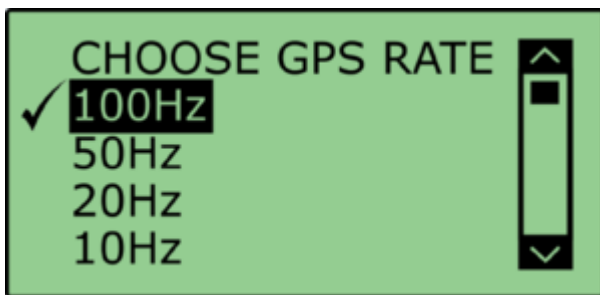

5. Select '**DYNAMICS**' and set the dynamic mode to '**NORMAL**', this Dynamics mode is best for ADAS tests, return to the '**VBOX**' setup menu.

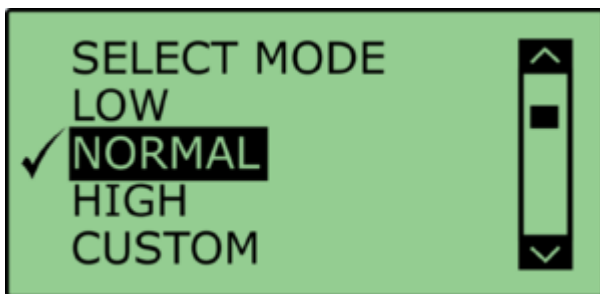

6. Select '**DGPS**' and set the DGPS mode to the same 2 cm mode that the Base Station is set to, return to the '**VBOX**' setup menu.

For further info on RTK modes see [RTK Configuration](#).

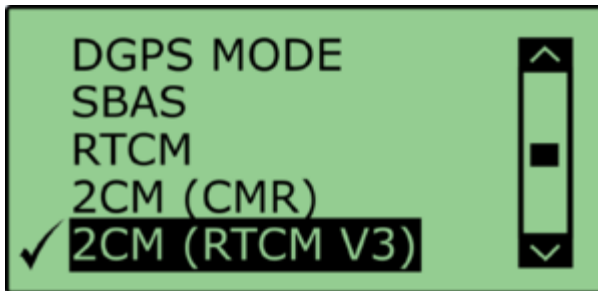

7. Select '**DGPS RS232 Rate**' and select the appropriate settings for your radios, return to the VBOX setup menu.

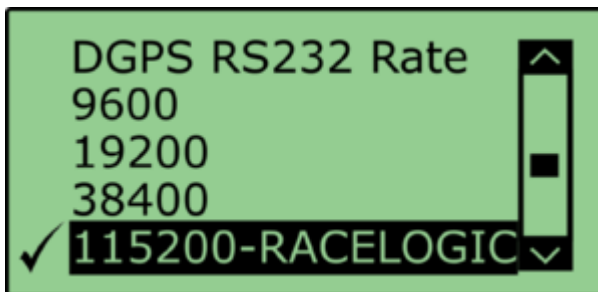

**Note:** To ensure that the VBOX receives the DGPS correction signal, the correct RS232 rate must be set. All Racelogic blue boxed radios use 115200 kbit/s, Satel grey boxed radios use either 19200 kbit/s or 38400 kbit/s.

8. Return to the main setup menu and select the '**ADAS**' option, then select '**SINGLE TARGET**' mode.

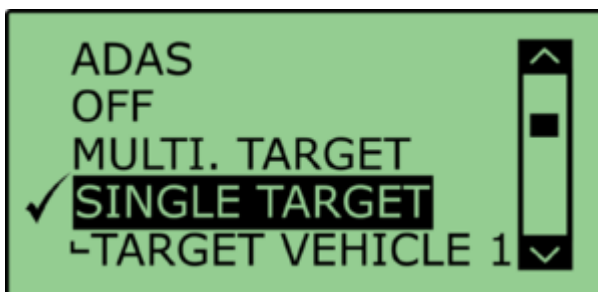

9. Select '**TARGET VEHICLE 1**' and return to the '**ADAS**' setup menu.

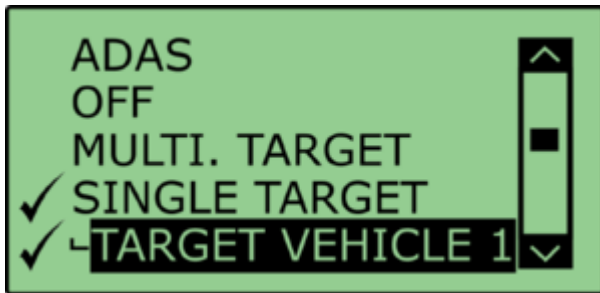

### Subject Vehicle

1. Connect VBOX Manager to the VBOX in the Subject Vehicle.
2. Repeat steps 2 – 8 in section 'Target Vehicle' above.
3. Select '**SINGLE TARGET**' mode and select '**SUBJECT VEHICLE**', return to the '**ADAS**' setup menu.

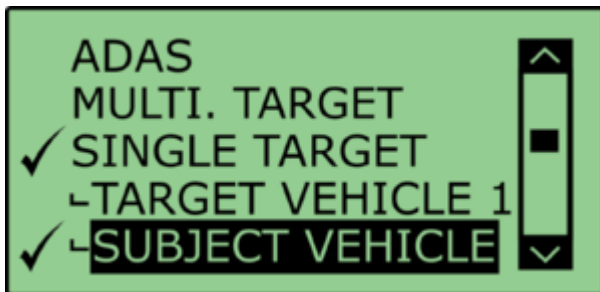

### ADAS Radio Link

1. Ensure the 2.4 GHz telemetry modems are connected as shown in [subject vehicle configuration](#) and [target vehicle configuration](#).
2. As 2.4 GHz transmissions are very direct, with a narrow beam width, care needs taking when mounting the antenna.  
Ensure they are:
  - On the highest part of the vehicle roof
  - Away from any nearby obstructions that could cause a potential blockage to the path of the signal
  - Mounted vertically to ensure maximum transmission power in the horizontal plane
  - Mounted at least 50 cm away from other radio antennas



When the 2.4 GHz modems are connected correctly the 'SER' light on the Subject VBOX will illuminate, indicating the reception of a serial data stream.



---

## Pre-Test Configuration

### Setting The Contact Points

After selecting the Subject Vehicle in either the multi or single target modes, the user can set the contact points by entering the '**CONTACT POINTS**' Menu.

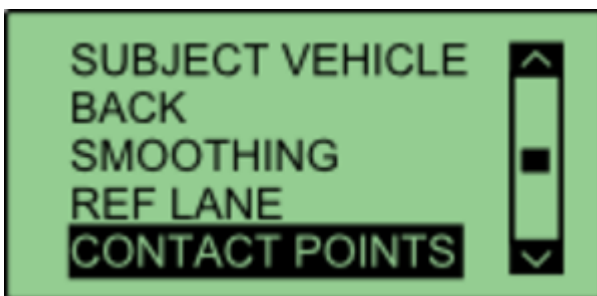

In this menu, it is possible to define contact points for either the 'Subject Vehicle' or 'Target Vehicle'. You can manually configure up to 2 contact points by entering a numerical offset, or you can set up to 24 contact points by using a GPS antenna.

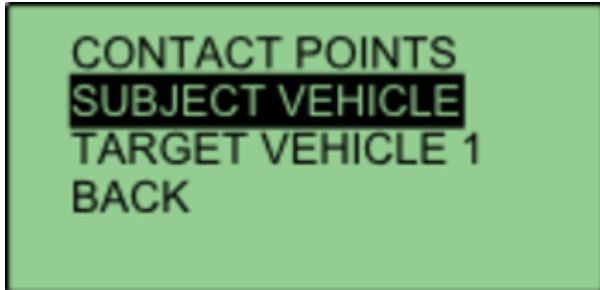

## Manually Entering Contact Points

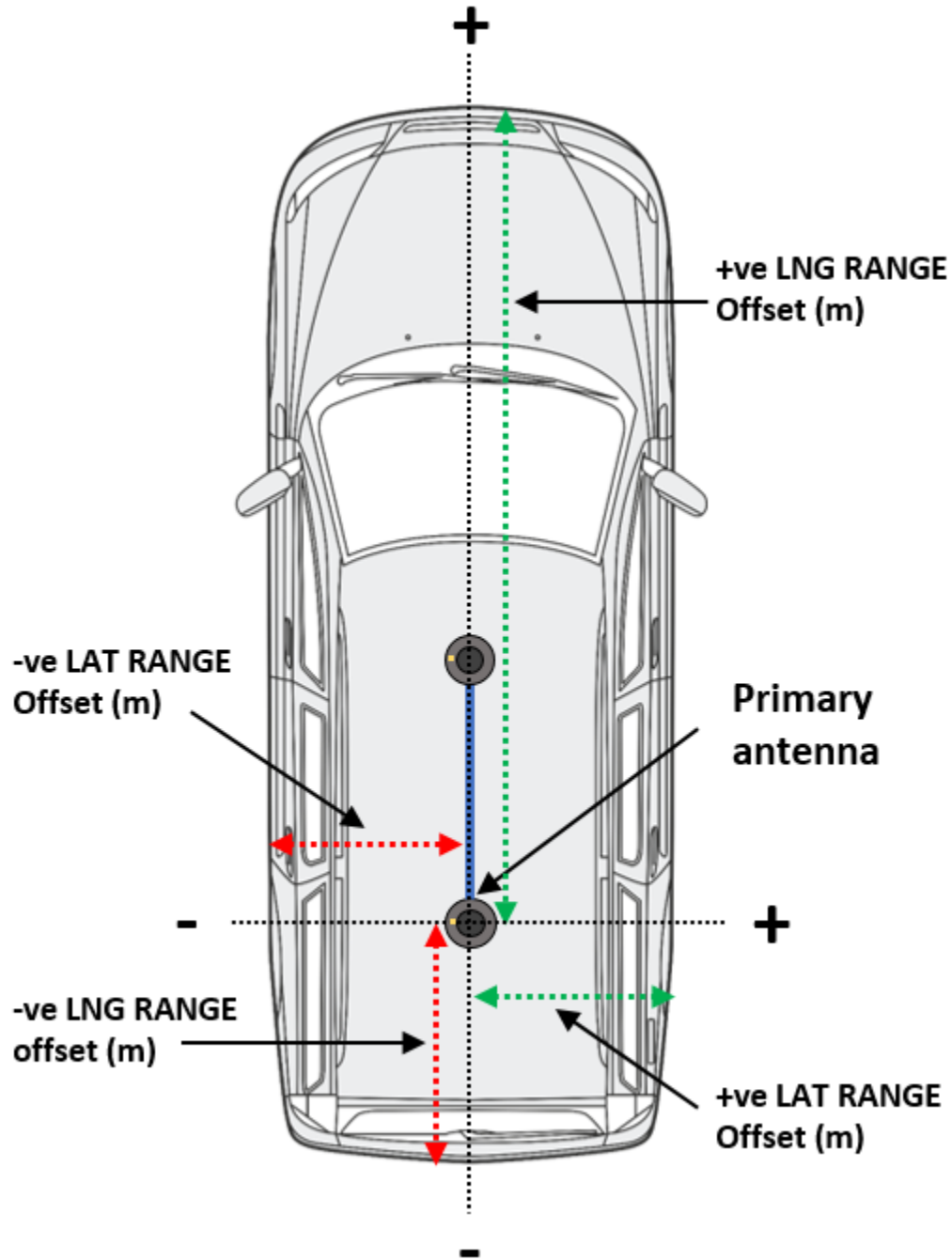

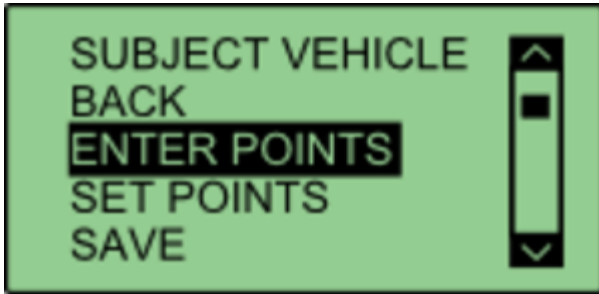

Select either '**SUBJECT VEHICLE**' or '**TARGET VEHICLE**' in the contact points menu.

Select '**ENTER POINTS**'.

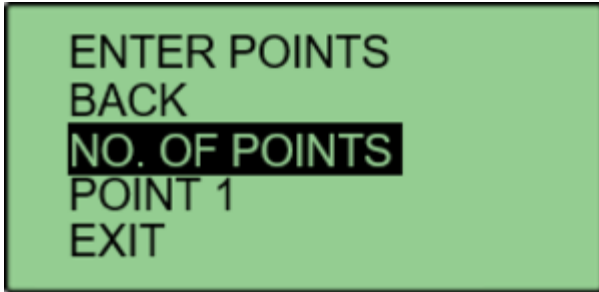

Select '**NO. OF POINTS**'.

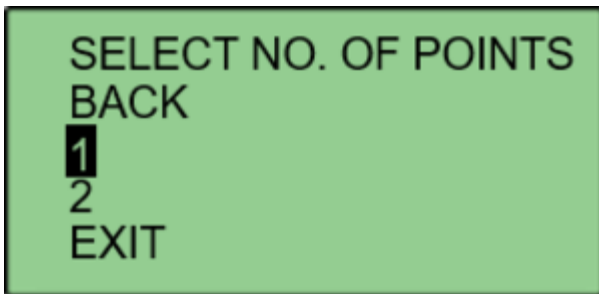

This menu allows the user to select whether 1 or 2 contact points are to be specified. The current number of selected points is highlighted with a tick next to the number. Selecting a different number will move that tick to that number. Select '**BACK**' once completed.

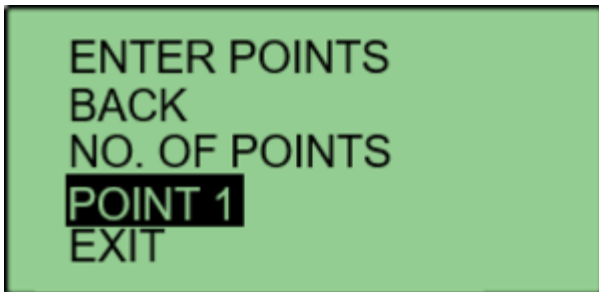

Select '**POINT 1**' to specify first contact point.



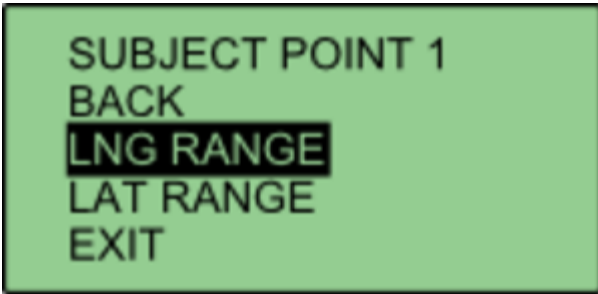

This menu allows the user to translate the **Primary** antenna point (or IMU if IMU integration is enabled) to a desired reference point on the vehicle. This is done by entering a numerical longitudinal ('LNG RANGE') and lateral ('LAT RANGE') offset value.



Selecting '**LNG RANGE**' allows the user to enter a longitudinal offset, with a forward offset being **POSITIVE** and a rearward offset being **NEGATIVE**. Pressing '**APPLY**' will store the value.



Selecting '**LAT RANGE**' allows the user to enter a lateral offset, with a rightwards offset being **POSITIVE** and a leftwards offset being **NEGATIVE**. Pressing '**APPLY**' will store the value. Select '**BACK**' to return to the previous menu.

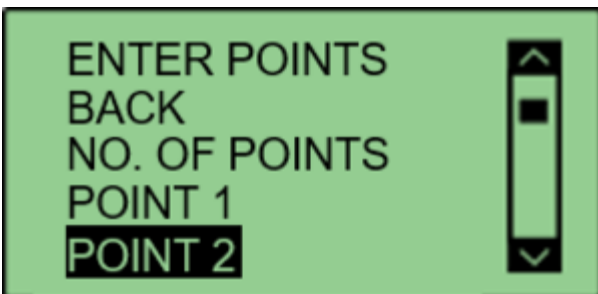

If the user selected 2 contact points in **NO. OF POINTS**, **POINT 2** will be displayed on the menu. Select '**POINT 2**' and repeat the above process.

Repeat this process to define the other vehicle.





## Setting Up To 24 Contact Points

Media, iframe, embed and object tags are not supported inside of a PDF.

First, connect a ground plane antenna to the VBOX.  
Select either '**SUBJECT VEHICLE**' or '**TARGET VEHICLE**' in the contact points menu. Select '**SET POINTS**'.

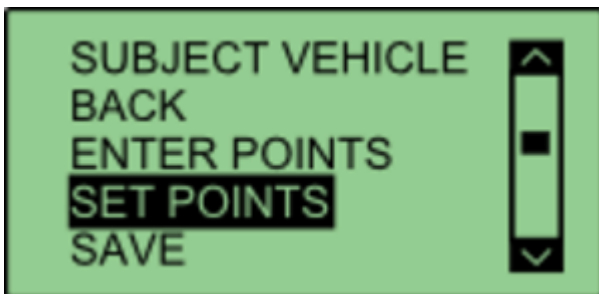

Using the survey pole, move the antenna to the desired contact point on the vehicle. Ensure there is a fixed RTK solution and select '**SET POINT**'.

If successful, VBOX Manager will display '**POINT 1 SAVED**'.



If there is no RTK fix, the point will not be saved and VBOX Manager will display '**POINT 1 NOT SET, NOT RTK FIXED**'.

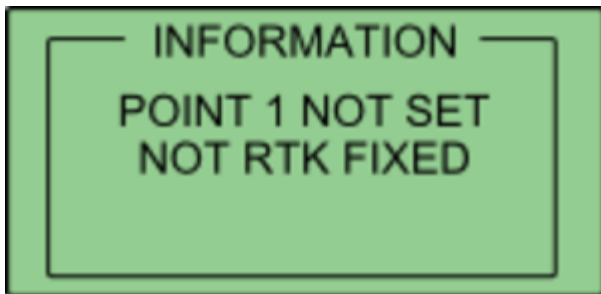

To set the next point, move the antenna to another desired point of contact and repeat the process. Repeat this process until all the desired points are set, or a limit of 24 is reached. Once all the desired points are set, move the antenna to the location of antenna A and select '**SET ANT A**'.

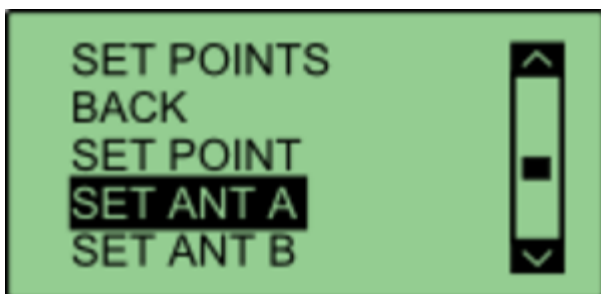

Then move the antenna to the location of Antenna B and select '**SET ANT B**'. This process can be repeated to define the other vehicle.

If multiple points have been set on either vehicle, the calculated ADAS parameters (range, angle etc) will always reference the nearest surveyed point.

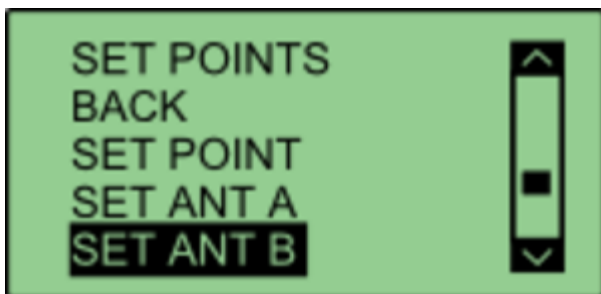

## Saving Vehicle Contact Points

After the required contact points have been surveyed, it is possible to save these points to the compact flash card by selecting '**SAVE**'.

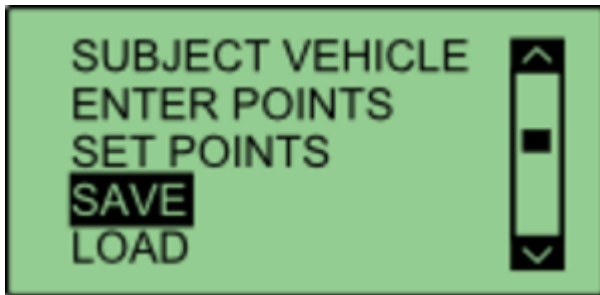

This allows the user to either overwrite a previously saved file, or create a new save file using the '**{CREATE NEW}**' option.

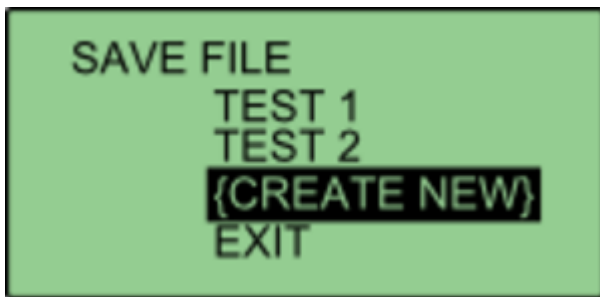

Selecting the '**{CREATE NEW}**' option will display an alpha numeric scroll wheel where the user can enter the desired file name.

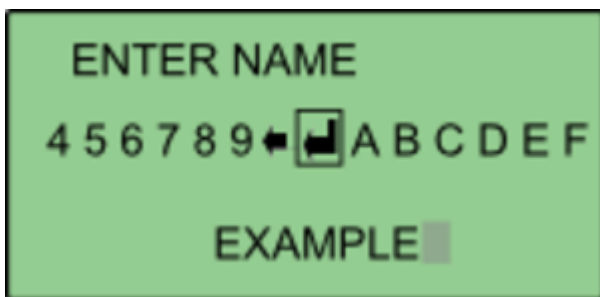

Once entered, VBOX Manager will display the '**SAVE SUCCESSFUL**' message.

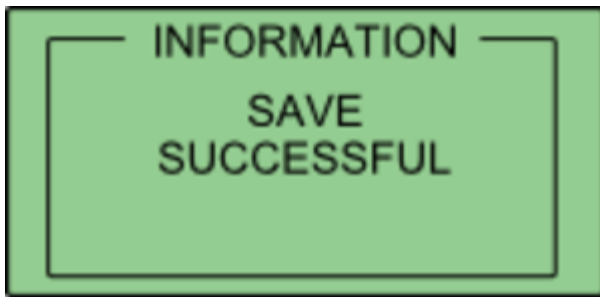

### Loading Vehicle Points

Select either '**SUBJECT VEHICLE**' or '**TARGET VEHICLE**' in the contact points menu. Then select '**LOAD**'.

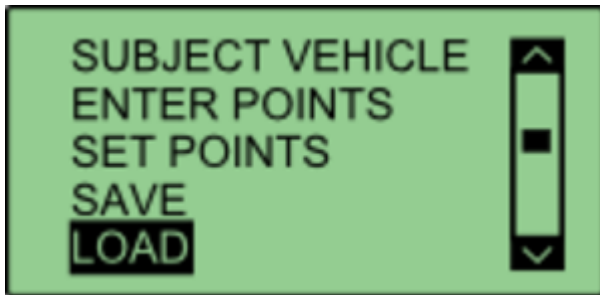

This will bring up a list of all previously saved files, which the user can select to load.



If successful, VBOX Manager will display 'LOAD SUCCESSFUL'.

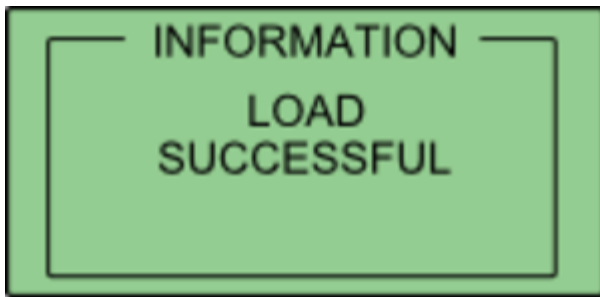

### Setting a reference line

A reference line is used to provide a very stable heading reference for the calculation of a noise free Lateral Difference Channel (LatDif-tg1) - see [parameter definitions](#) for more detail.

1. Under the '**SINGLE TARGET**' option within the '**ADAS**' menu, navigate to '**SUBJECT VEHICLE**' and select '**REF LINE**'.
2. Move the vehicle to the first nominated point along a straight line that runs perfectly parallel to the test track. (A good method for this is to get the outside front and rear tyres perfectly aligned on a marked straight line).
3. Within the '**REF LINE**' menu, select '**SET PNT 1**'.

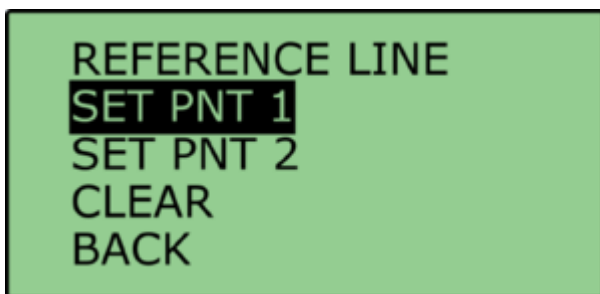

4. Move the vehicle to a distance at least 100 m along the straight line, ensuring that the car is re-aligned.



5. Select 'SET PNT 2'.

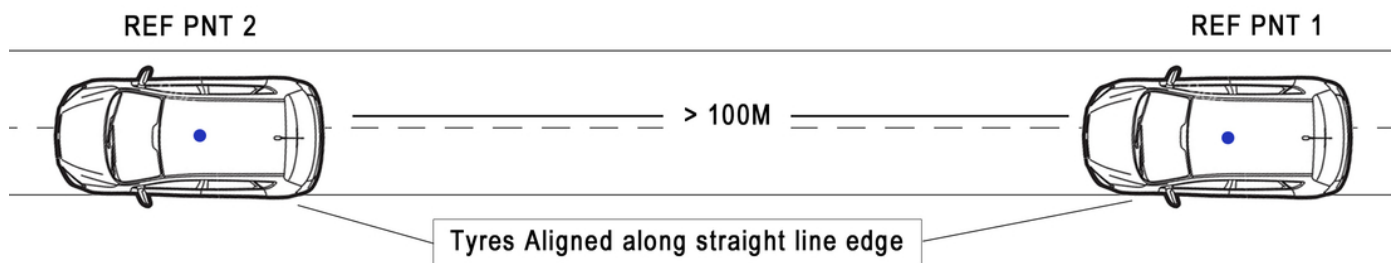
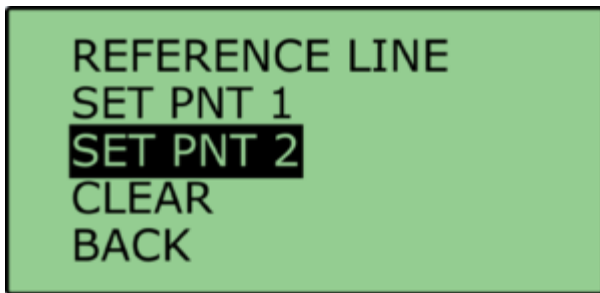

## Smoothing

If the box is set into twin antenna mode, the smoothing menu will not be present as the calculations will run off of the True heading provided by the twin antenna lock.

It is recommended that if user intends to set multiple points on the car, they enable the dual antenna.

There are two configurable variables linked to heading smoothing; 'Smoothing Distance' and 'Speed Threshold'. Due to the nature of the vehicle separation measurement and calculation process many channels are derived using the heading of the vehicle which can inherently be noisy. To overcome this heading can be smoothed with a dynamic smoothing routine.



## Smoothing Distance

The vehicle heading is normally calculated between the current and previous sample. Even with the stability of RTK position GPS position can vary by a few millimetres with respect to the original. When the travelled distance between subsequent samples is short (low speeds) this leads to a potential larger potential error in the calculated heading.

This smoothing routine allows the user to force a 'Smoothing Distance' over which heading is calculated. This is therefore dynamic, resulting in a variable number of samples used to determine the smoothing level on the heading; the lower the speed the more samples that are used. With 100 Hz logging and a smoothing distance of 1 m at 72 km/h, the heading is calculated over the previous 5 samples, whilst at 15 km/h the heading would be calculated over the previous 26 samples.

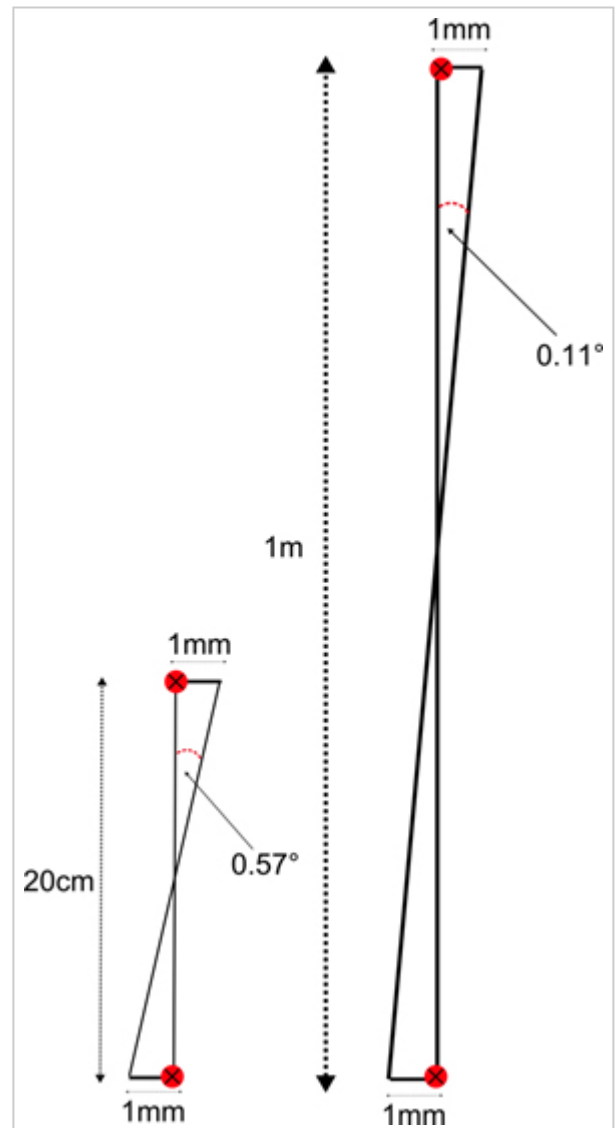

Vehicle travelling at 20 km/h in a straight path (not to scale)

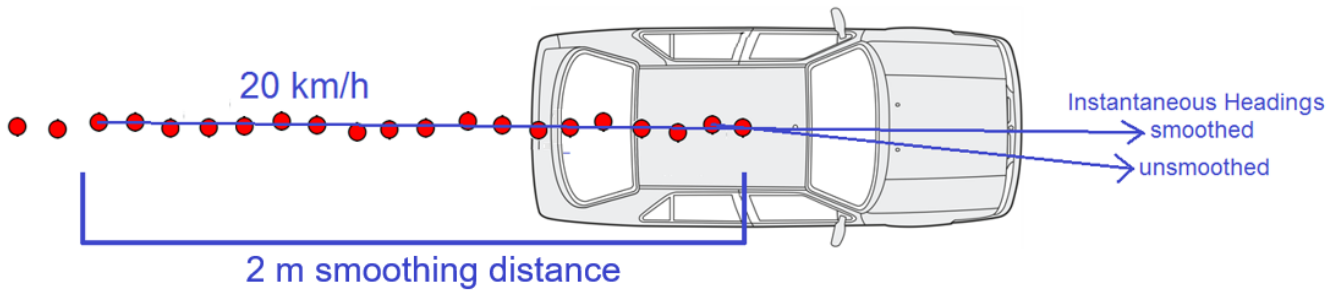

Above: Shows the improvement on vehicle heading from using smoothing distance

### Setting A Smoothing Distance

1. Using VBOX Manager, go to the '**ADAS**' menu and go to the '**SINGLE TARGET**' menu and select '**SUBJECT VEHICLE**'.

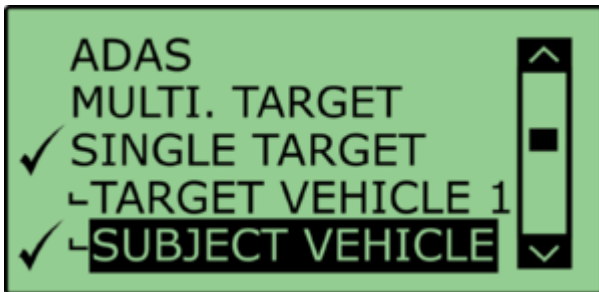

2. Select '**SMOOTHING**' from the '**SUBJECT VEHICLE**' menu.





3. Select '**SMOOTHING DIST**' and enter the smoothing option for the Subject Vehicle, from the options between 0.00 m and 2.00 m.

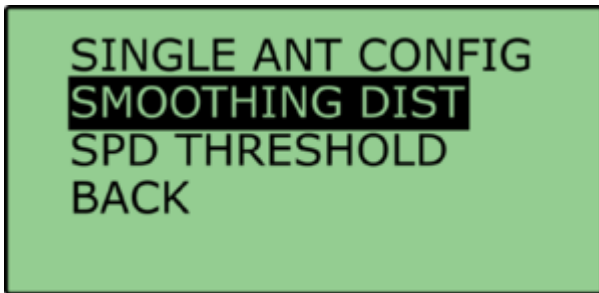

4. For typical Vehicle Separation applications we recommend a smoothing distance of 1 m.

### Speed Threshold

Due to the nature of how heading is calculated, even when smoothing is applied at very low speeds and when the vehicle is stationary the heading channel can become very noisy and unusable, this in turn results in many of the Vehicle Separation channels becoming noisy at low speed and unusable when stationary. This is solved by fixing the heading below a configurable Speed Threshold.

1. To set the speed threshold repeat steps 1 and 2 above, then select '**SPD THRESHOLD**' and enter the speed threshold option for the Subject Vehicle.

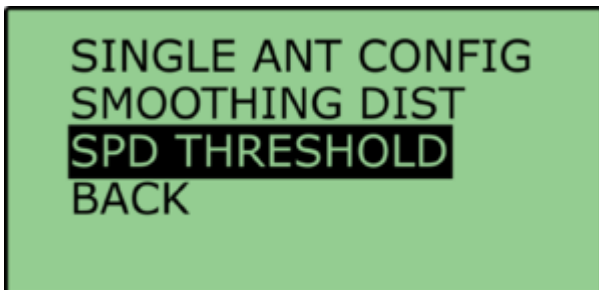

2. We recommend a Speed Threshold of 5 km/h.



---

## Single Target 'Duplex Mode'

In this mode all of the Vehicle Separation parameters are also calculated at the Target Vehicle. This is facilitated by creating a 'Duplex' ADAS radio link between the Subject and Target Vehicle.

This is **NOT** possible in 'Multi Target' mode.

The channels calculated in the Target Vehicle are the same as the channels calculated by the VBOX in the Subject Vehicle. They are not new channels calculated in opposite respect; Target to Subject.

### Duplex Mode Benefits

- All vehicle separation channels can be viewed live by the driver of the Target Vehicle.
- A Throttle and Braking robot can be connected to the Target VBOX CAN Bus so that the separation and speed of the Target Vehicle can be controlled more consistently.
- The logging of the Target Vehicle VBOX can be automatically synchronised to the Subject Vehicle logging.



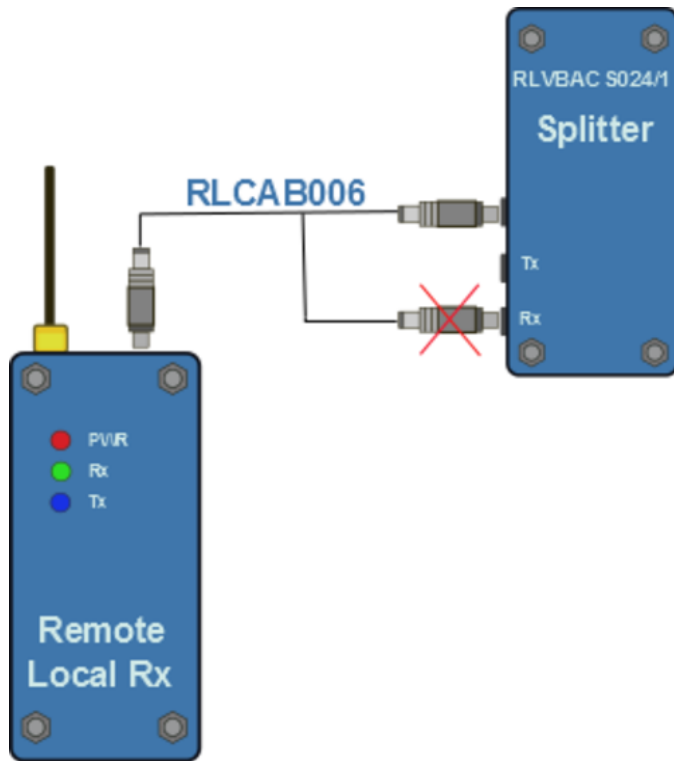

## Hardware configuration

The hardware at the Subject Vehicle should be connected as per the [Subject Vehicle separation diagram](#), except from the following important change.

The ADAS link radio needs to be unplugged from the 'RX' socket and plugged into the unlabelled socket on the RLVBACS024/1 splitter.

This will allow a full Duplex link to exist between the Subject and Target VBOX's.

You should now see that the RX and TX lights of both ADAS radios will now be flashing.

## Pre-Test Configuration

The Duplex Radio link allows any configurations that are set in the Subject VBOX to be instantly communicated to the Target VBOX, so that both boxes produce the same values for all Veh Sep parameters.

On power up and during the first communication between each VBOX there will also be a synchronisation of configurations between each VBOX.

### 'SYNC TARGET'

When in Duplex mode (Single target only), the target VBOX has to understand which contact points have been set in the subject vehicle. To do this, the user must have a valid radio link between the two VBOXs and then select the '**SYNC TARGET**' option under the '**SUBJECT VEHICLE**' menu.

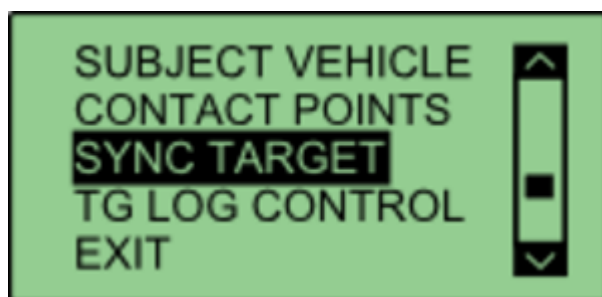

Selecting this option will transmit all the subject vehicles settings to the target vehicle, allowing live data to be displayed in the target vehicle.

## Logging

It is possible to synchronise the logging of both VBOX's in this Duplex mode.

To make this possible:

- Set the logging mode in both VBOX's to '**LOG CONTINUOUSLY**'.
- Connect VBOX Manager to the Subject vehicle VBOX.
- Then use VBOX Manager to start and stop the file logging.

The logging of data at the Target vehicle will stop and start in synch with the VBOX Manager control.

*Note: If you stop the logging with the 'LOG' button on the Target VBOX then you will overwrite this auto-logging control*



## FCW - Static Point (Static Base)

The Static Point feature of the VB3iSL-RTK firmware allows the user to set any arbitrary target point as the static reference point for all positional calculations. This facility can be used when a dummy pedestrian or static vehicle is the test target.

This also requires the use of a static Racelogic Base Station to ensure position accuracies of up to 2 cm.

---

### Hardware Configuration

The following diagram shows the hardware configuration required for Static Point testing. The items greyed out are not essential to run this test but many customers will find them a useful addition.

Connection between the VB3i and computer should be made via USB or Bluetooth to ensure optimum performance.

**Please ensure that all vehicle antennas are correctly positioned and connected.**



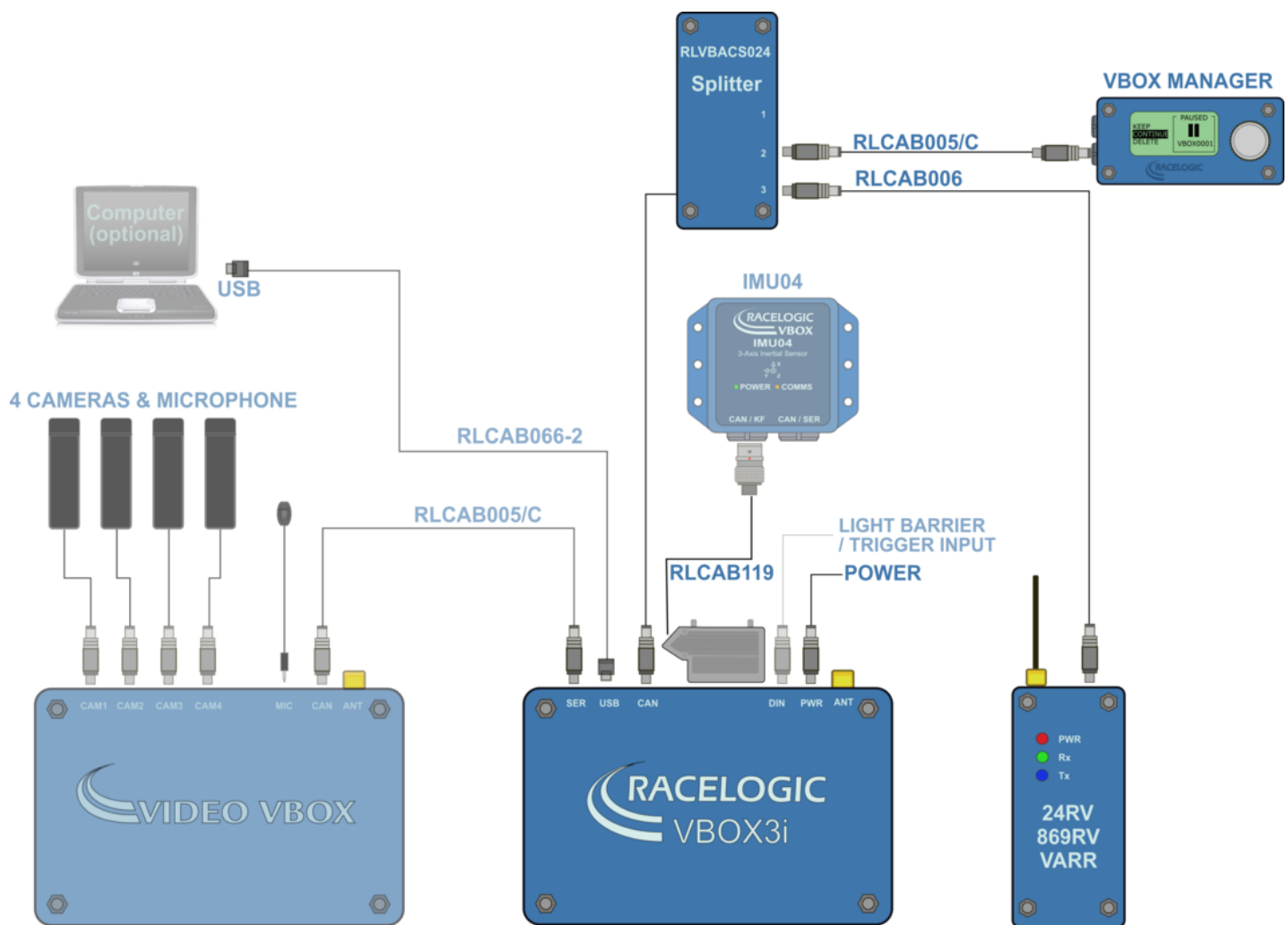

---

## VBOX Configuration

### Subject Vehicle

1. Connect VBOX Manager to the VBOX in the Subject Vehicle.
2. Enter the setup menu of VBOX Manager.
3. Select the '**VBOX**' option.
4. Select '**LOG RATE**' and set the rate to '**100 Hz**', then select '**BACK**' to return to the '**VBOX**' setup menu.

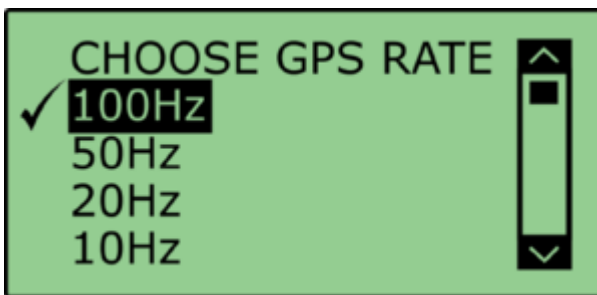

5. Select '**DYNAMICS**' and set the dynamic mode to '**NORMAL**', this Dynamics mode is best for ADAS tests, return to the '**VBOX**' setup menu.

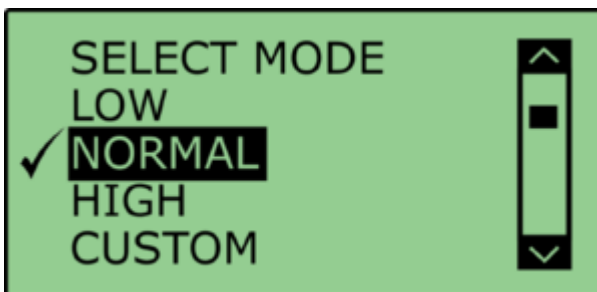

6. Select '**DGPS**' and set the DGPS mode to the same 2 cm mode that the Base Station is set to, return to the '**VBOX**' setup menu.

For further info on RTK modes see [RTK Configuration](#).

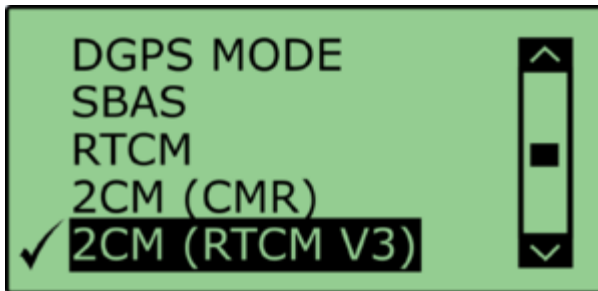

7. Select '**DGPS RS232 Rate**' and select the appropriate settings for your radios, return to the VBOX setup menu.

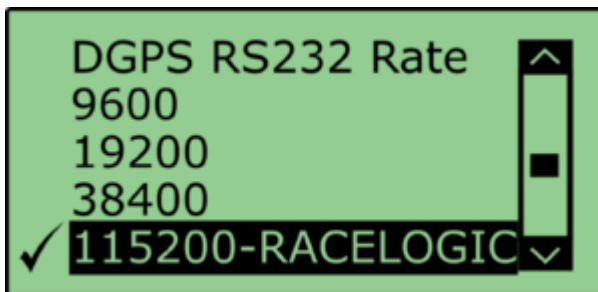

**Note:** To ensure that the VBOX receives the DGPS correction signal, the correct RS232 rate must be set. All Racelogic blue boxed radios use 115200 kbit/s, Satel grey boxed radios use either 19200 kbit/s or 38400 kbit/s.

8. Return to the main setup menu and select the '**ADAS**' option, then select '**STATIC POINT**' mode.

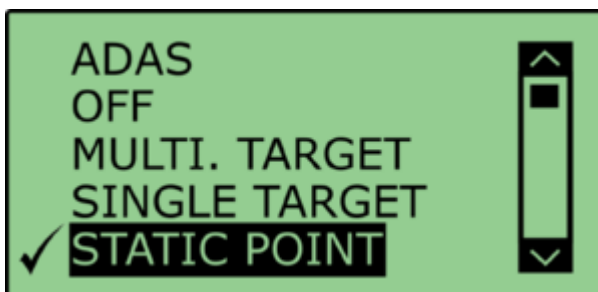



## Base Station

A static Base Station must be used for the VBOX to gain the RTK 2 cm positional accuracy. Moving Base cannot be used because a static Base Station is the only way to create a reference to a fixed point like a nominated static point.

See the [Base Station user guide](#) for Base Station installation.

**Important Note: The Base Station GPS antenna must be in exactly the same location for marking the static point and for subsequent testing. It is also good practice to save the location into the Base Station memory.**

The VBOX front panel will indicate the required RTK Fixed status, with the illumination in green of the 'DIFF' light.



## Pre-test Configuration

### Setting the 'Static Point'

1. Position the vehicle touching the desired location of the Static Point.
2. Within the '**STATIC POINT**' menu select the '**SET**' option. This sets the location of the Static Point.

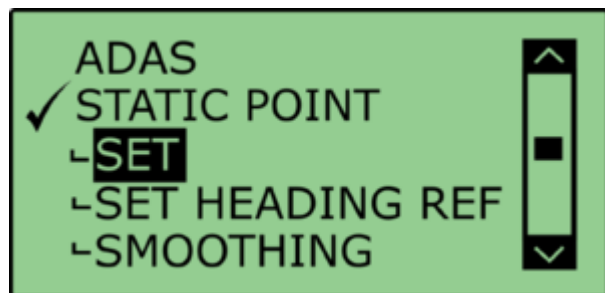

3. Once the Static Point has been set, drive the vehicle away in a straight line along the test track to a distance of over 100 m. Select '**SET HEADING REF**'.

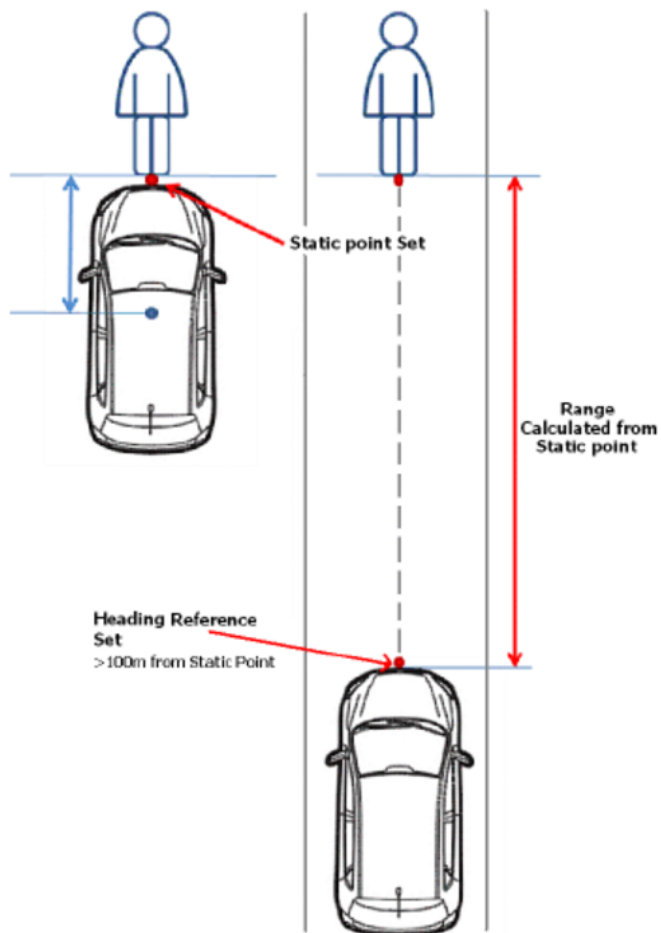
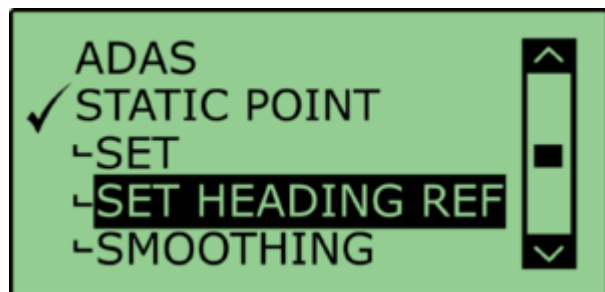

### Smoothing Levels

There are two configurable variables linked to heading smoothing; 'Smoothing Distance' and 'Speed Threshold'. Due to the nature of the vehicle separation measurement and calculation process many channel are derived using the heading of the vehicle which can be noisy. To overcome this the heading can be smoothed with a dynamic smoothing routine.



Using VBOX Manager, go to the 'ADAS' menu and go to the 'STATIC POINT' menu and select 'SMOOTHING'.

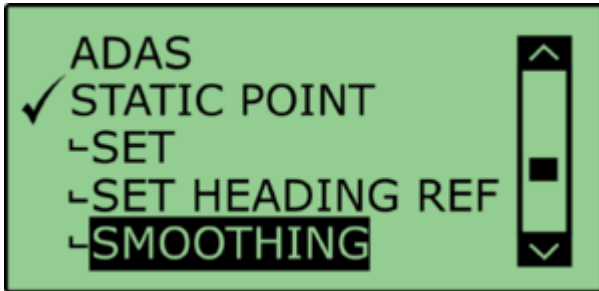

### Smoothing Distance

The smoothing routine is calculated between the current and previous samples. The previous sample to be used is determined using a Smoothing Distance, this results in a variable number of samples used to determine the smoothing level on the heading; the lower the speed the more samples that are used. With 100 Hz logging and a smoothing distance of 1.1 m at 80 km/h the heading is calculated over the previous 5 samples whilst at 15 km/h the heading is calculated over the previous 26 samples.

Select '**SMOOTHING DIST**' and enter the smoothing option between 0.00 m and 2.00 m. **A smoothing distance of 1.00 m is recommended.**

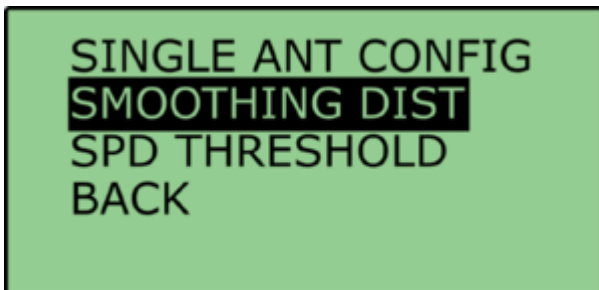

## Speed Threshold

Due to the large number of sample in a small distance when travelling at low speed the heading channel can become very noisy, this in turn results in many of the Vehicle Separation channels becoming noisy at low speed. When the speed threshold is set to a certain speed the heading is locked when the vehicle travels under that speed.

1. To set the speed threshold repeat steps above in 'Smoothing Levels', then select '**SPD THRESHOLD**' and enter the speed threshold option.

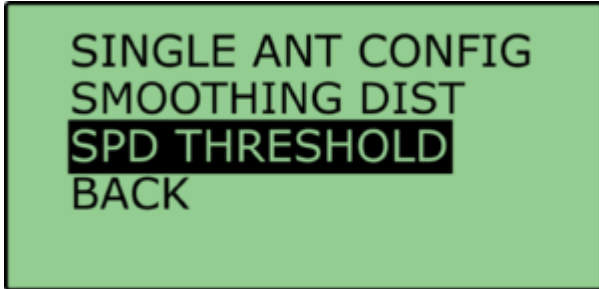

2. We recommend a Speed Threshold of 5 km/h.



## LDWS - Curved Lane

Our Lane Departure system allows for accurate measurement of range and speed with a defined lane edge. It's ideal for testing vehicle Lane Departure Warning Systems (LDWS).

Combining the VB3iSL-RTK with the Video VBOX and vehicle CAN data provides a complete vehicle testing package. Lane Departure Warning testing consists of two stages:

1. **Lane Survey**

During this stage curved line edges can be surveyed using the Lane Survey trolley (RLACS173-XXX\*) to provide an accurate survey of the lane under test. \*XXX denotes the type radio frequency – please refer to your distributor for further information.

2. **Measurement Tests**

In this stage the surveyed line edges are loaded into the test VBOX to act as a measurement reference. Then the Lane Departure test can be conducted with the VBOX measuring all of the parameters listed below with respect to the surveyed lane edge.

---

## Hardware Configuration

The following diagrams show the recommended hardware configuration for each vehicle. The items greyed out are not essential but many customers may find them beneficial.

Connection between the VB3i and computer should be made via USB or Bluetooth to ensure optimum performance.

**Please ensure that all vehicle antennas are correctly positioned and connected.**



# Lane Survey Configuration

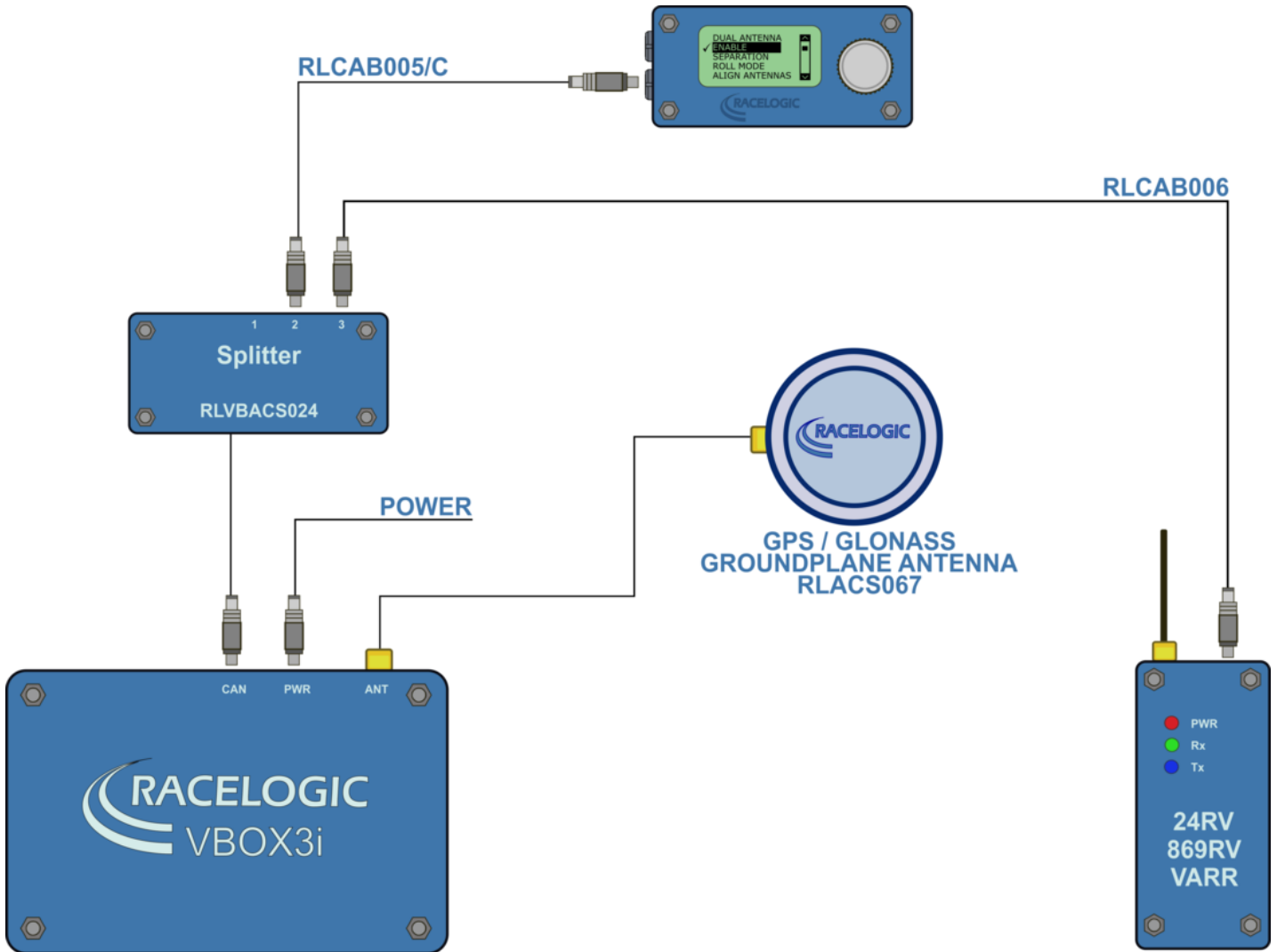

## Lane Departure Test Schematic

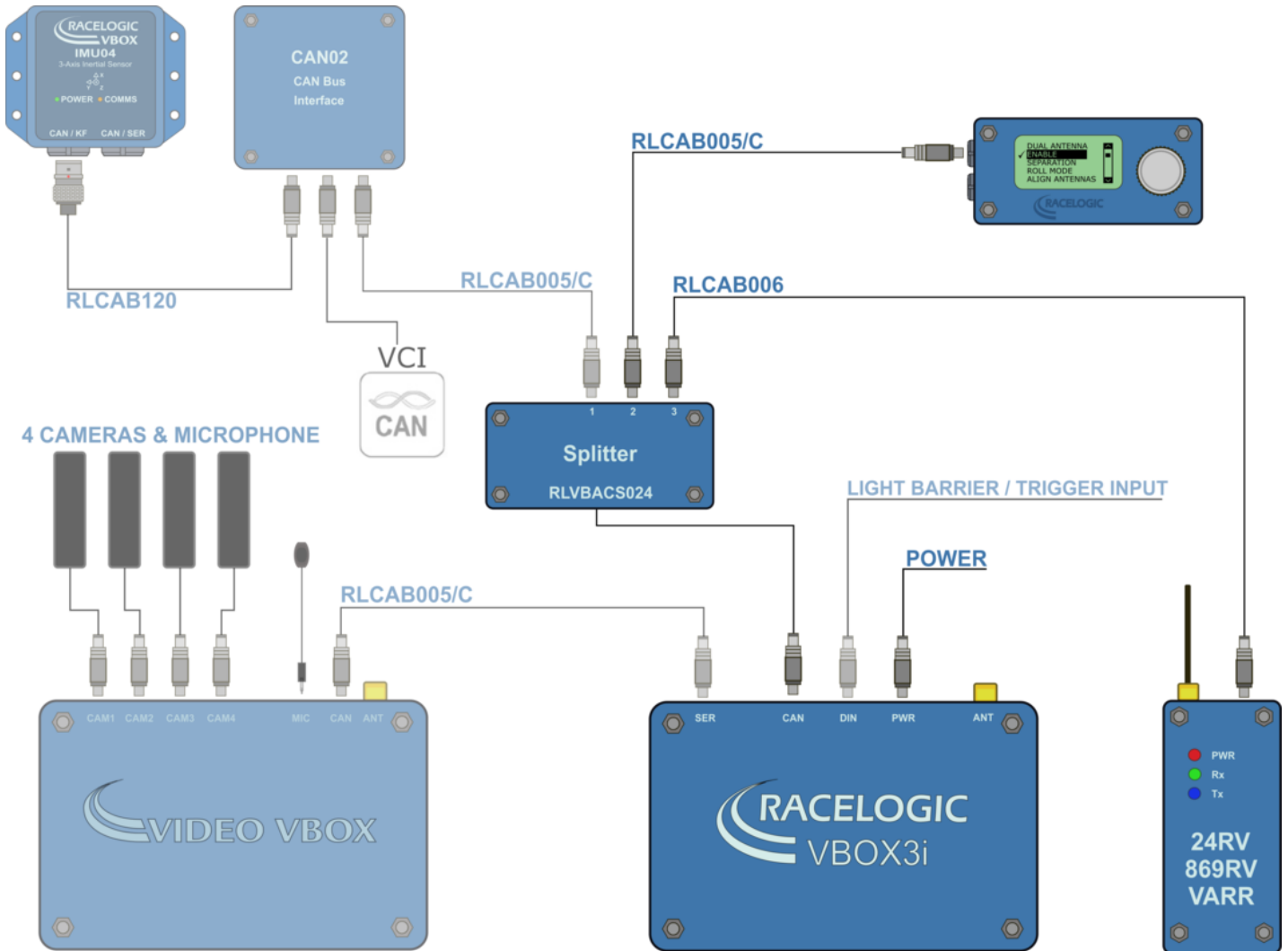

## VBOX Configuration

### Base Station

A static Base Station must be used for the VBOX to gain the RTK 2 cm positional accuracy. This is required for the lane survey as well as during testing.

Moving Base cannot be used because a static Base Station is the only way to create a reference to a static location, which then allows measurement to other static objects like lane edges.

See the [Base Station user guide](#) for Base Station installation.



**Important Note: The Base Station GPS antenna must be in exactly the same location for lane survey and for subsequent testing. It is also good practice to save the location into the Base Station memory.**

Confirm that the VBOX unit is in RTK 'Fixed' DGPS status, indicated by the following:



'DIFF' LED on the VBOX front panel is illuminated green.

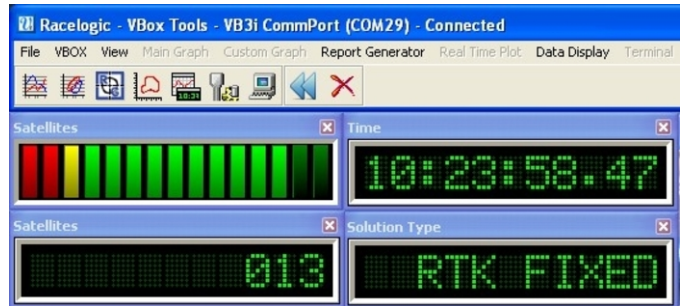

A VBOX Tools live window set to Solution Type shows 'RTK FIXED'.

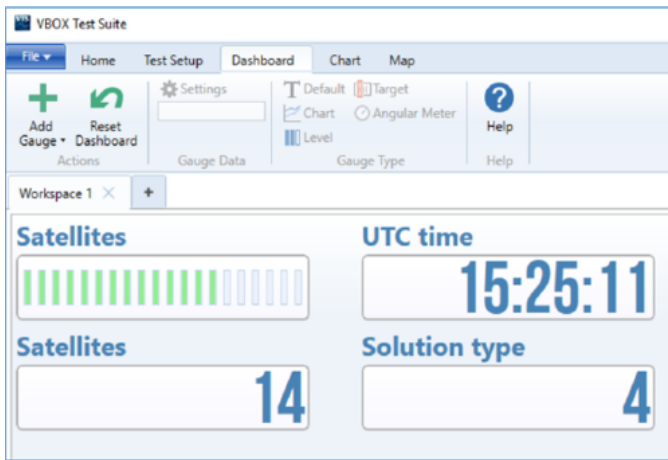

A VBOX Test Suite live Workspace window set to Solution type shows '4' (RTK fixed).

## Process Summary

Using Racelogic ADAS systems, there are two setup methods dependent on the straightness of the test lane edge. The following schematic shows the options for determining Lane Departure Warning parameters.





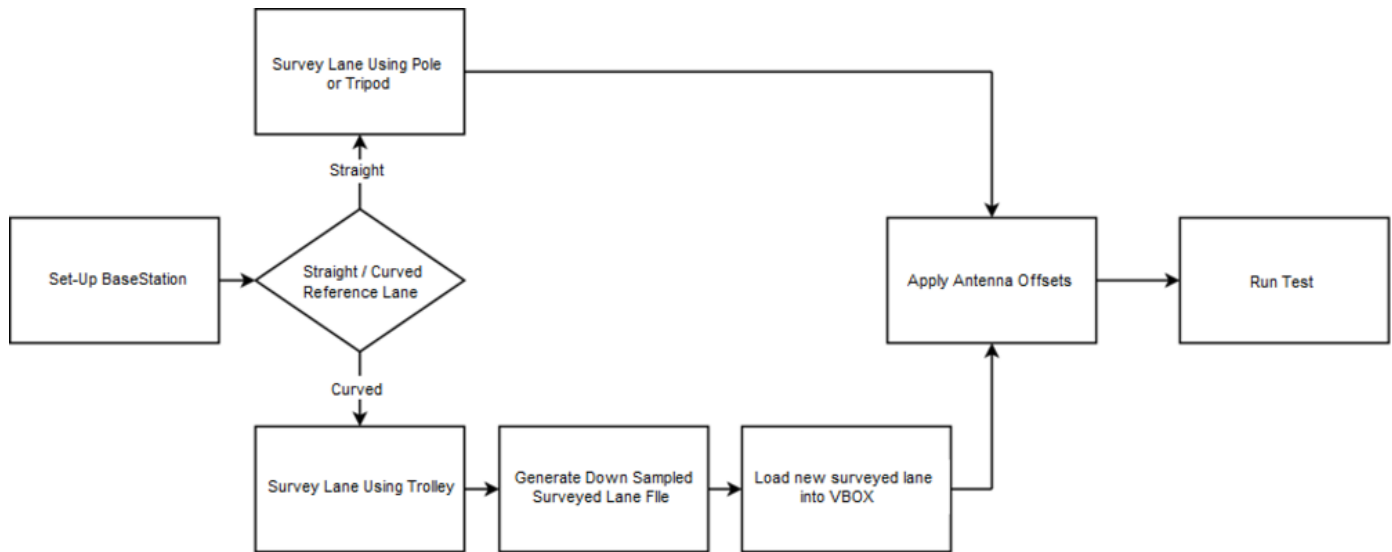

## Hardware Configuration – Lane Survey

1. Connect the VBOX equipment as shown in [Lane Survey Configuration](#) with the GPS antenna mounted on top of a survey pole (RLACS168).
2. Enter the setup menu of VBOX Manager.
3. Select the '**VBOX**' option.
4. Select '**LOG RATE**' and set the rate to 100 Hz, then select '**BACK**' to return to the '**VBOX**' setup menu.

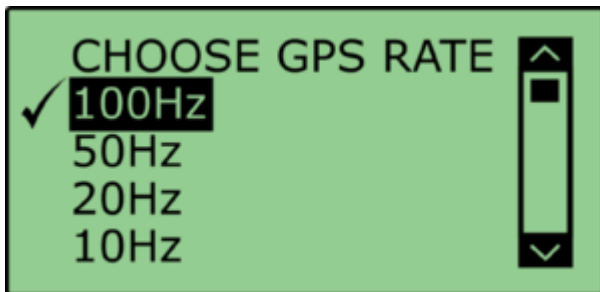

5. Select '**DYNAMICS**' and set the dynamic mode to '**NORMAL**', this Dynamics mode is best for ADAS tests, return to the '**VBOX**' setup menu.



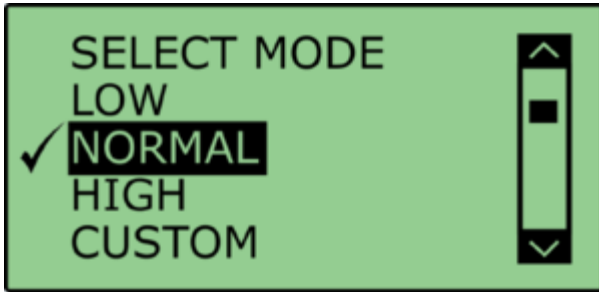

6. Select '**DGPS**' and set the DGPS mode to the same 2 cm mode that the Base Station is set to, return to the '**VBOX**' setup menu.

For further info on RTK modes see [RTK Configuration](#).

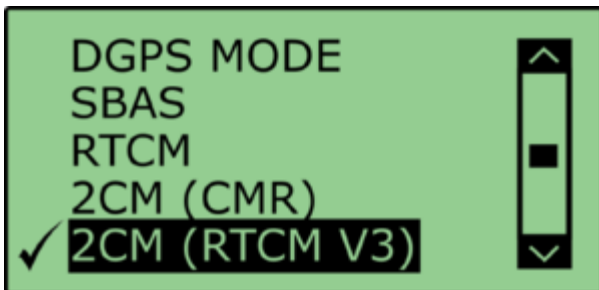

7. Select '**DGPS RS232 Rate**' and select the appropriate settings for your radios, return to the '**VBOX**' setup menu.

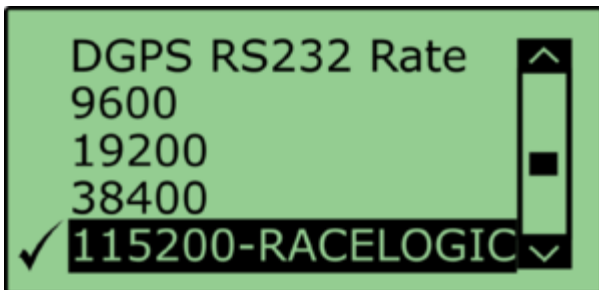

**Note:** To ensure that the VBOX receives the DGPS correction signal, the correct RS232 rate must be set. All Racelogic blue boxed radios use 115200 kbit/s, Satel grey boxed radios use either 19200 kbit/s or 38400 kbit/s.

## Lane Survey

If the test lane is curved then this method can be used to obtain the reference lane data. This method requires the use of a Survey Trolley (RLACS173-XXX where XXX represents the frequency of the Base Station).



When using the Survey Trolley data is recorded at 10 Hz and provides a more accurate representation of a lane on a curved road.

Please see the Survey Trolley instruction manual for instructions on how to assemble the equipment.

## Multiple Lanes

It is possible to load three surveyed lanes into the VBOX which can then be individually selected via VBOX Manager.

It is **NOT** possible for the VBOX to make measurements to more than 1 lane edge at a time.

For 2 cm positional accuracy during the Lane Departure Warning Test, an RTK Base Station is required.

## Curved Line

1. Assemble the Survey Trolley and mount the VBOX, radio modem, ACS112L Li-Ion battery and VBOX Manager into the surveying back pack.

*Assembly instructions can be found [here](#)*

2. Select '**LANE DEP**' and then select '**SURVEY MODE**'.

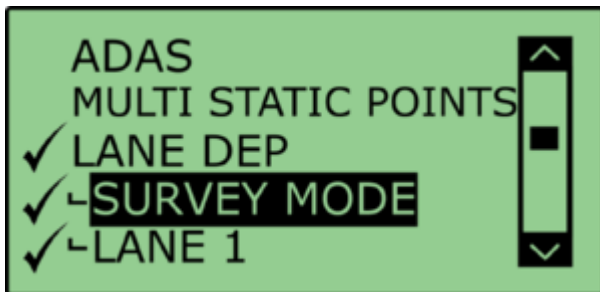

3. Exit the '**ADAS**' menu and return to the VBOX Manager home screen. This presents a new display designed for controlling the survey mode function.



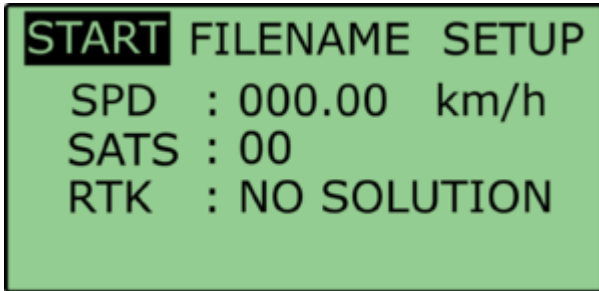

4. When the VBOX displays 'RTK Fixed' you can start to survey the lane.

5. Place the centre line of the Survey Trolley over the lane edge to be surveyed and select '**START**' on VBOX Manager to start the logging before moving.

6. When the lane surveying is completed stop the logging and revert the VBOX back to standard operating mode by de-selecting '**SURVEY MODE**' enabled in step 2.

7. Remove the CF card from the VBOX and download the recorded reference lane .vbo file from the VBOX onto a PC.

8. Run VBOX File Processor software, and using the '**Load Input File**' option select the recorded reference lane .vbo.

9. Expand the '**ADAS**' drop down menu and select the '**Lane Data Generation**' process block, either by double clicking or dragging and dropping it in to the 'Selected Process Blocks' window.

10. Click on the '**Process Output File**' at the bottom of the screen to create the required .VBC file.

*Note: The software will automatically append '\_Processed' on to the end of the reference lane file name (i.e. VBOX0005\_Processed.vbc). If you wish to change the filename to something more representative click on the three dot '...' icon at the bottom of the screen.*

*Note: Use a maximum of 8 characters to allow the full file name to be displayed on VBOX Manager.*

11. Copy the created .VBC file on to the root directory of the compact flash card being used in the VB3iSL-RTK unit.

12. Place the Compact Flash card back into the VB3iSL-RTK unit.



13. Enter the **'LANE DEP'** option within **'ADAS'** configuration on VBOX Manager.

14. Select the appropriate lane number and select **'SET LANE'**.



15. Select the **'LOAD'** option.

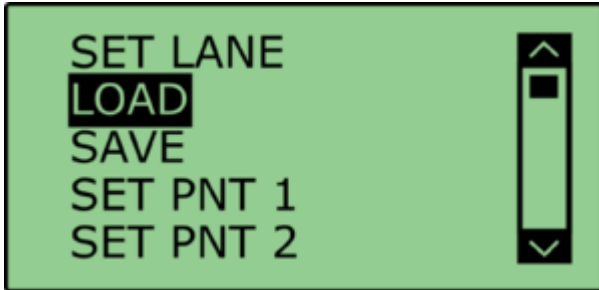

16. The VBOX will browse the CF card for .vbc files, select the appropriate .vbc file for the reference lane in question.



The lane is now loaded into the VBOX and is ready to be used to generate live Lane Departure values.



---

## Pre-Test Configuration

### Corner Position

In accordance with the NHTSA “Lane Departure Warning System NCAP Confirmation Test December 2008, “Lane departure is said to occur when any part of the two dimensional polygon used to represent the test vehicle breaches the in board lane line edge. In the Case of tests performed in this procedure, the outside front corner of the polygon will cross the line edge first”.

“The corners of the polygon are defined by the lateral and longitudinal locations where the plane of the outside edge of each tire makes contact with the road. This plane is defined by running a perpendicular line from the outer most edge of the tire to the ground.”

The following provides a guide to setting the two front left and right measurement positions.

### Manual Corner Position

When using the down sampled survey lane as a reference lane it is not possible to use the auto corner position function within the VBOX Manager. In this instance it is necessary to manually enter the offsets into VBOX Manager.

1. Within the '**LANE DEP**' option of VBOX Manager select '**CORNER POS**'.

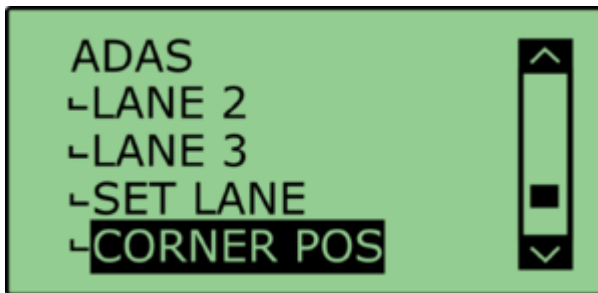

2. Select '**SET FL POS**'.

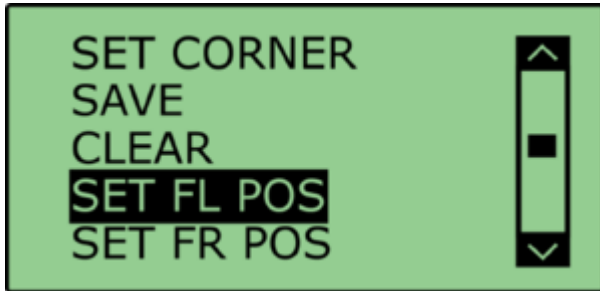

3. To manually set the corner position select '**LNG DIST**'.

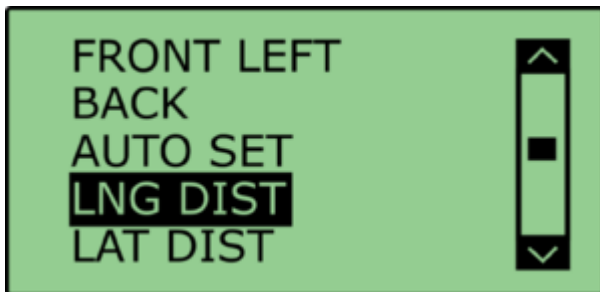

4. Enter the 'LNG DIST' value in accordance with the following orientation:



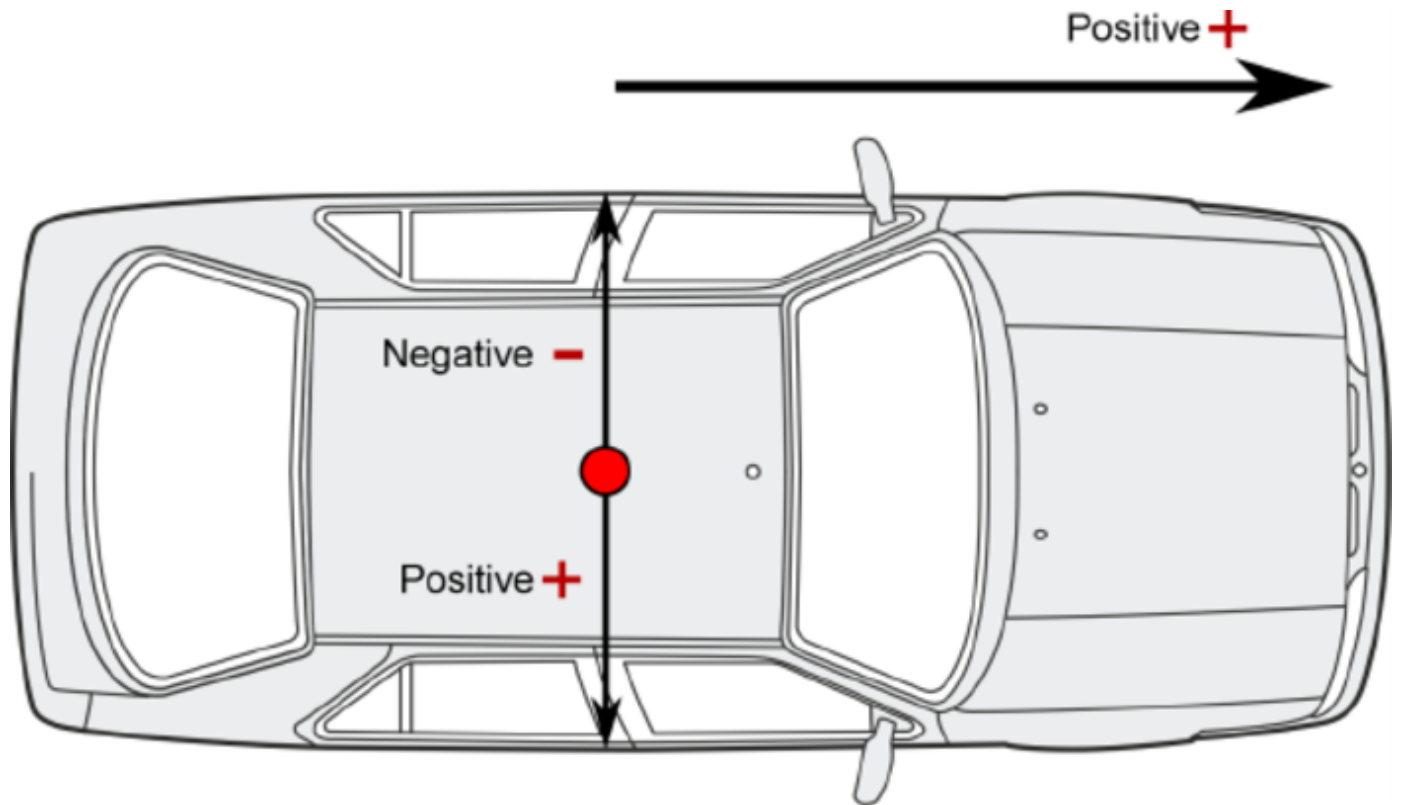

*Note: The corner position must be in-front of the GPS antenna, i.e. a positive longitude.*

5. Repeat step 4 but for the 'LAT DIST'.
6. Repeat steps 2-5 for FR, RL and RR as required.

### Saving and Loading Corner Positions

Once corner positions have been set in VBOX Manager, they can be saved as a .vbc file and recalled later for repeatability.

**If you have .vbc files saved using pre VBOX firmware version 1.2.5, you will need to load these back in, and re-save out to make them compatible with latest firmware.**

*Note: For corner positions to be recalled accurately, the GPS antenna location on the car and the location of the Base Station GPS antenna must be identical as when the data was recorded.*





1. Within the '**CORNER POS**' option of the '**ADAS**' menu select '**SAVE**'.

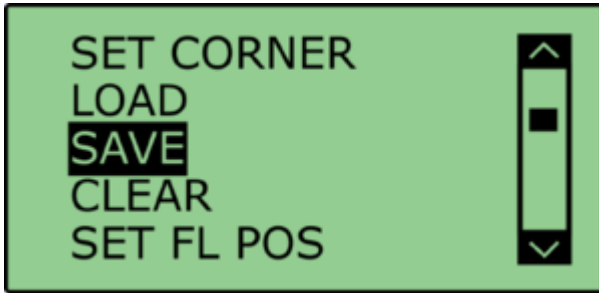

2. Within the '**SAVE**' menu select the appropriate file name. This will be saved onto the CF card as a .vbc file.

3. To load a .vbc file containing offset data, select the '**LOAD**' option from the '**CORNER POS**' menu. This will present a list of saved .vbc files containing corner position offsets. Selecting the appropriate file loads these values into the VB3iSL-RTK firmware and allows for range values to be calculated to these corner positions.

## Heading Smoothing

There are two configurable variables linked to heading smoothing; 'Smoothing Distance' and 'Speed Threshold'. Due to the nature of the vehicle separation measurement and calculation process many channels are derived using the heading of the vehicle which can be noisy. To overcome this heading can be smoothed with a dynamic smoothing routine.

Under the '**LANE DEP**' option within the '**ADAS**' menu, select '**SMOOTHING**'.

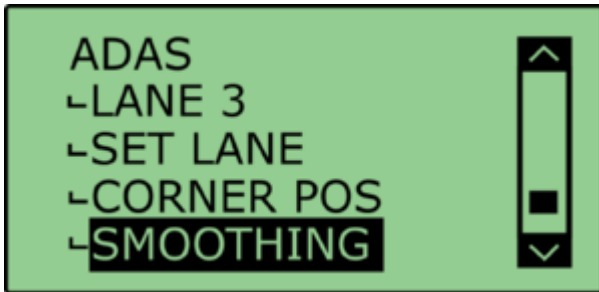

## Smoothing Distance

The smoothing routine is calculated between the current and previous samples. The previous sample to be used is determined using a Smoothing Distance, this results in a variable number of samples used to determine the smoothing level on the heading; the lower the speed the more samples that are used. With 100 Hz logging and a



smoothing distance of 1.1 m at 80 km/h, the heading is calculated over the previous 5 samples, whilst at 15 km/h the heading is calculated over the previous 26 samples.

Select '**SMOOTHING DIST**' and enter the smoothing option between 0.00 m and 2.00 m. **A smoothing distance of 2.00 m is recommended.**

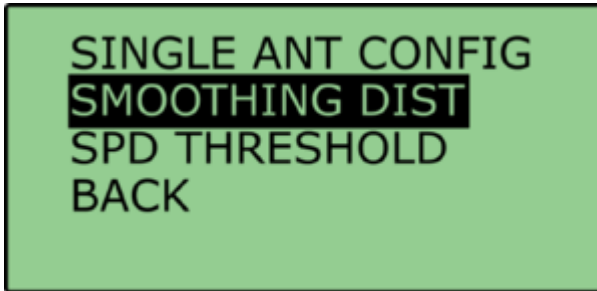

### Speed Threshold

Due to the large number of samples in a small distance when travelling at low speed the heading channel can become very noisy, this in turn results in many of the Vehicle Separation channels becoming noisy at low speed. When the speed threshold is set to a certain speed the heading is locked when the vehicle travels under that speed.

1. To set the speed threshold repeat steps above in 'Heading Smoothing', then select '**SPD THRESHOLD**' and enter the speed threshold option.

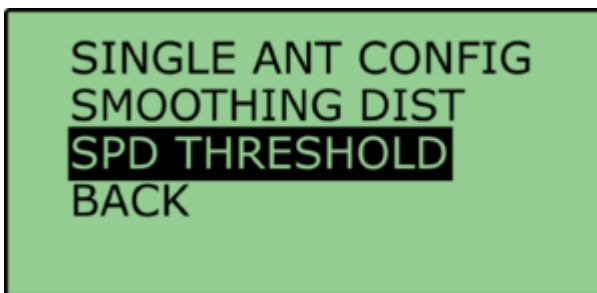

2. We recommend a Speed Threshold of 5 km/h.



## LDWS - Straight Lane

Our Lane Departure system allows for accurate measurement of range and speed with a defined lane edge. It's ideal for testing vehicle Lane Departure Warning Systems (LDWS).

Combining the VB3iSL-RTK with the Video VBOX and vehicle CAN data provides a complete vehicle testing package. Lane Departure Warning testing consists of two stages:

1. **Lane Survey**

During this stage line edges are surveyed by marking 2-8 points along the straight line edge.

2. **Measurement Tests**

In this stage the surveyed line edges are loaded into the test VBOX to act as a measurement reference. Then the Lane Departure test can be conducted with the VBOX measuring all of the parameters listed below with respect to the surveyed lane edge.

---

## Hardware Configuration

The following diagrams show the recommended hardware configuration for each vehicle. The items greyed out are not essential but many customers may find them beneficial.

Connection between the VB3i and computer should be made via USB or Bluetooth to ensure optimum performance.

**Please ensure that all vehicle antennas are correctly positioned and connected.**



# Lane Survey Configuration

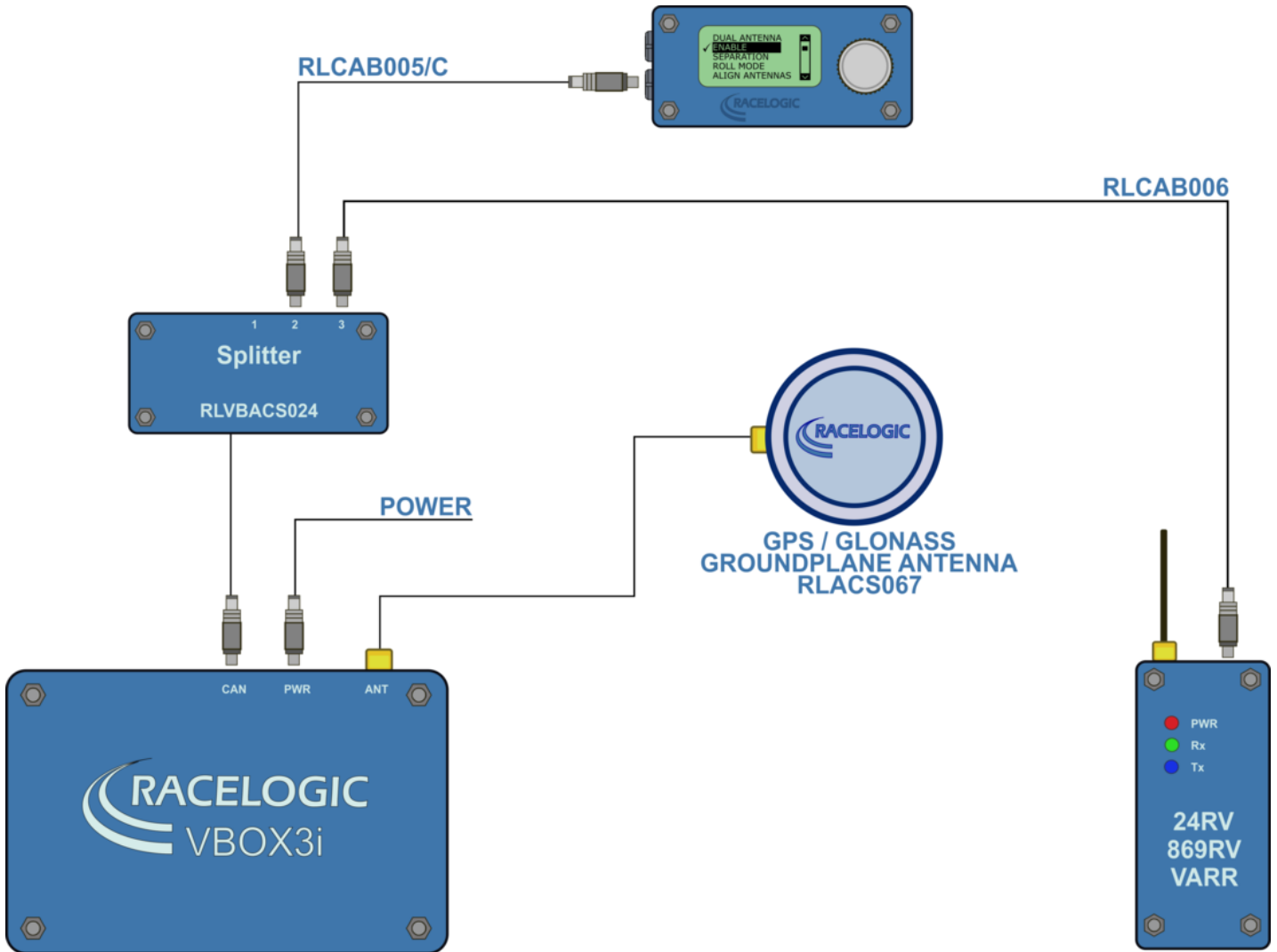

## Lane Departure Test Schematic

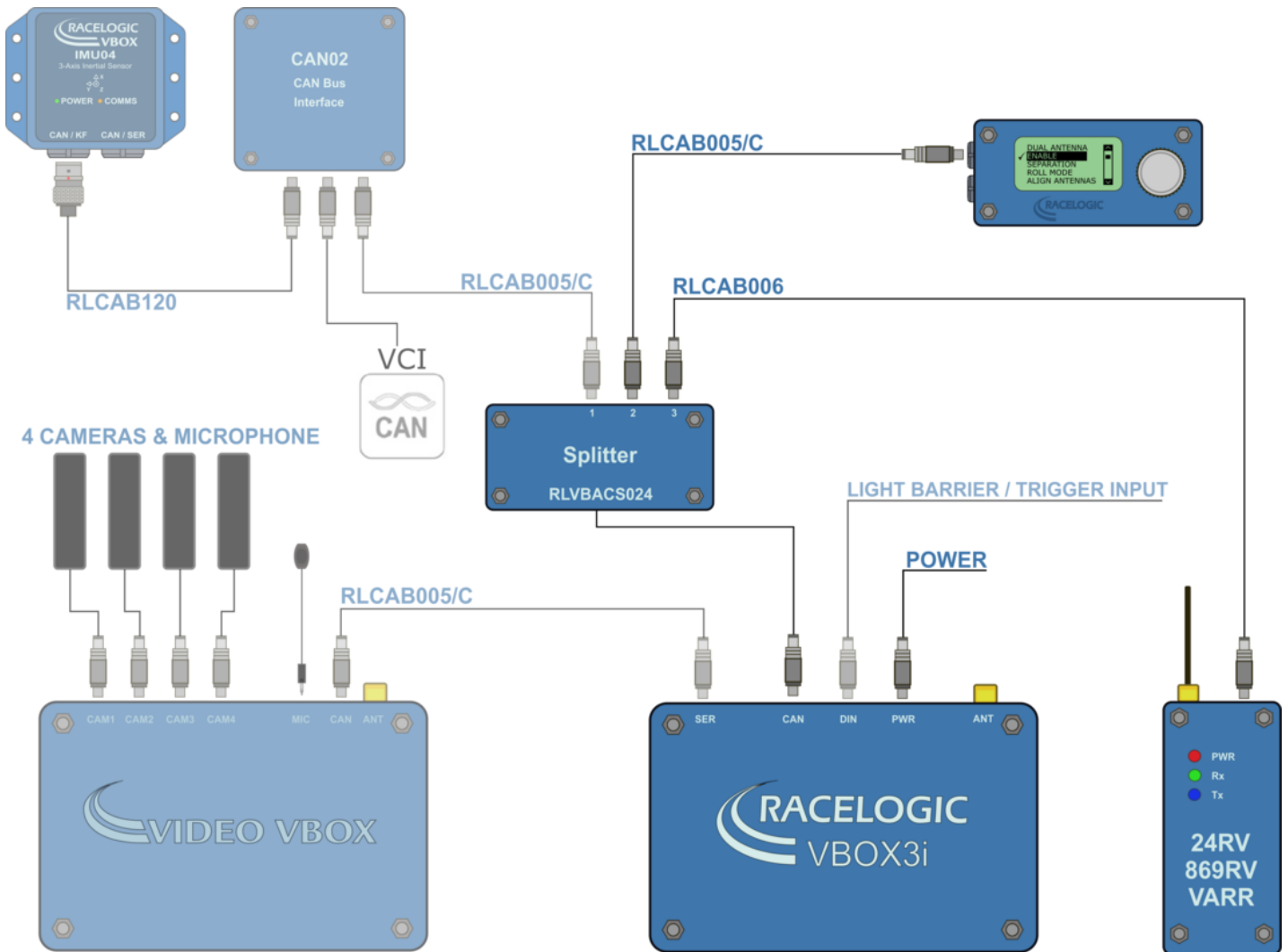

## VBOX Configuration

### Base Station

A static Base Station must be used for the VBOX to gain the RTK 2 cm positional accuracy. This is required for the lane survey as well as during testing.

Moving Base cannot be used because a static Base Station is the only way to create a reference to a static location, which then allows measurement to other static objects like lane edges.

See the [Base Station user guide](#) for Base Station installation.



**Important Note:** The Base Station GPS antenna must be in exactly the same location for lane survey and for subsequent testing. It is also good practice to save the location into the Base Station memory.

Confirm that the VBOX unit is in RTK 'Fixed' DGPS status, indicated by the following:



'DIFF' LED on the VBOX front panel is illuminated green.

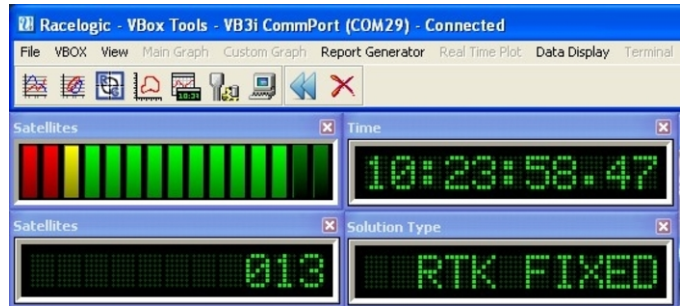

A VBOX Tools live window set to Solution Type shows 'RTK FIXED'.

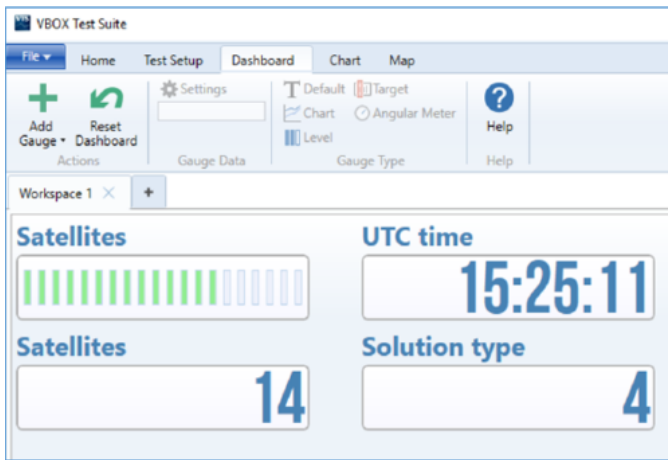

A VBOX Test Suite live Workspace window set to Solution type shows '4' (RTK fixed).



## Process Summary

Using the Racelogic ADAS systems there are two setup methods dependent on the straightness of the test lane edge. The following schematic shows the options for determining Lane Departure Warning parameters.

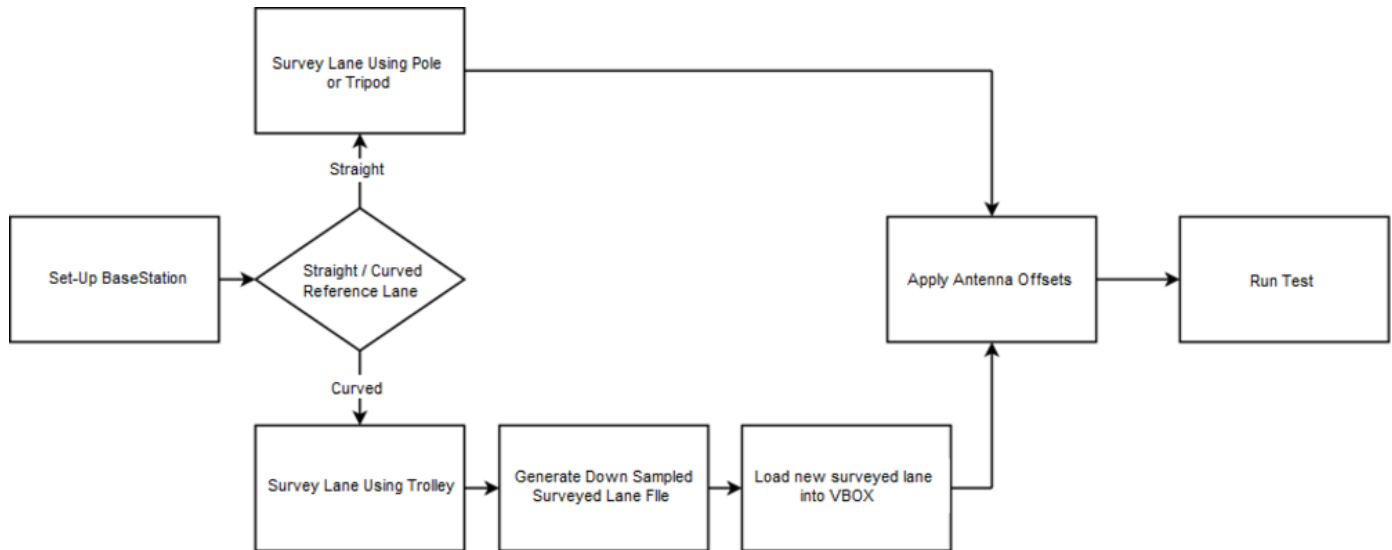

## Hardware Configuration – Lane Survey

1. Connect the VBOX equipment as shown in [Lane Survey Configuration](#) with the GPS antenna mounted on top of a survey pole (RLACS168).
2. Enter the setup menu of VBOX Manager.
3. Select the '**VBOX**' option.
4. Select '**LOG RATE**' and set the rate to 100 Hz, then select '**BACK**' to return to the '**VBOX**' setup menu.

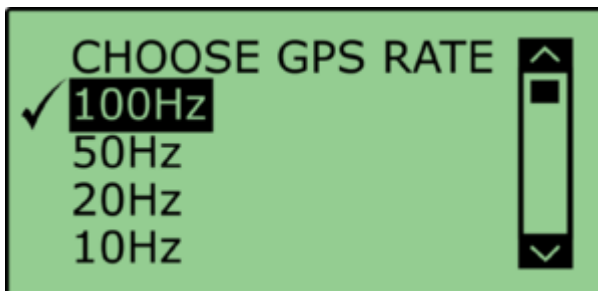

5. Select '**DYNAMICS**' and set the dynamic mode to '**NORMAL**', this Dynamics mode is best for ADAS tests, return to the '**VBOX**' setup menu.

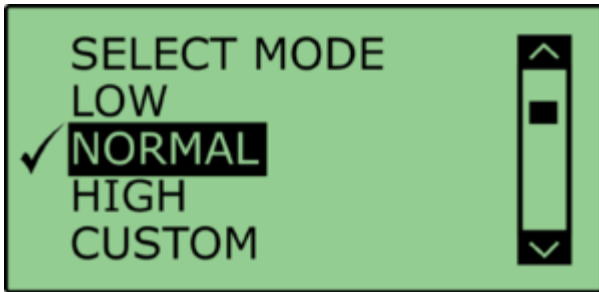

6. Select '**DGPS**' and set the DGPS mode to the same 2 cm mode that the Base Station is set to, return to the '**VBOX**' setup menu.

For further info on RTK modes see [RTK Configuration](#).

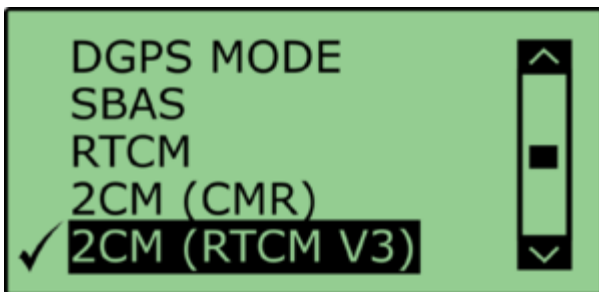

7. Select '**DGPS RS232 Rate**' and select the appropriate settings for your radios, return to the '**VBOX**' setup menu.

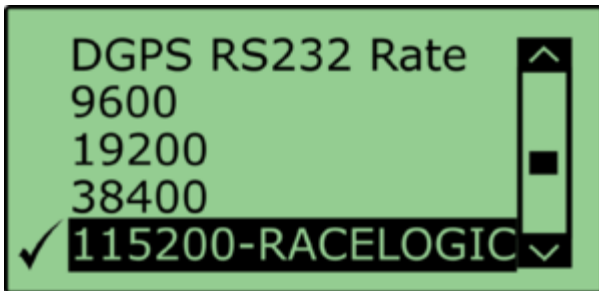

**Note:** To ensure that the VBOX receives the DGPS correction signal, the correct RS232 rate must be set. All Racelogic blue boxed radios use 115200 kbit/s, Satel grey boxed radios use either 19200 kbit/s or 38400 kbit/s.





## Lane Survey

Within the Racelogic ADAS firmware there are two ways for surveying a lane. If the test is intended for straight lanes only then a simple point-to-point lane (utilising up to 8 points along the lane) can be surveyed using a VBOX 3i RTK and a survey pole as described in 'Straight Line' section below.

If the test lane is not straight enough to be represented by 8 points then an alternative method can be used to obtain the reference lane data. This method requires the use of a Survey Trolley (RLACS173-XXX where XXX represents the frequency of the Base station). When using the Survey Trolley data is recorded at 10 Hz and provides a more accurate representation of a lane on a curved road. Please see the Survey Trolley instruction manual for instructions on how to assemble the equipment.

## Multiple Lanes

It is possible to load three surveyed lanes into the VBOX which can then be individually selected via VBOX Manager.

It is **NOT** possible for the VBOX to make measurements to more than 1 lane edge at a time.

For 2 cm positional accuracy during the Lane Departure Warning Test an RTK Base Station is required.

## Straight Line

1. Connect the VBOX equipment as shown in [Lane Survey Configuration](#).
2. Place the Vehicle near to the edge of the first lane that you plan to survey.
3. Place the GPS antenna connected to the vehicle system onto the supplied Tripod or a suitable Survey pole.
4. Place the supplied tripod over the Lane edge and use a Plumb line hanging from underneath the GPS antenna to ensure that the GPS antenna is directly over the road side edge of the lane edge.
5. Mark this point on the Ground with paint or Sticky tape, as you will need to come back to it if you wish to Auto set the Antenna offsets.





6. On VBOX Manager go to the '**LANE DEP**' menu options and select '**LANE 1**'.

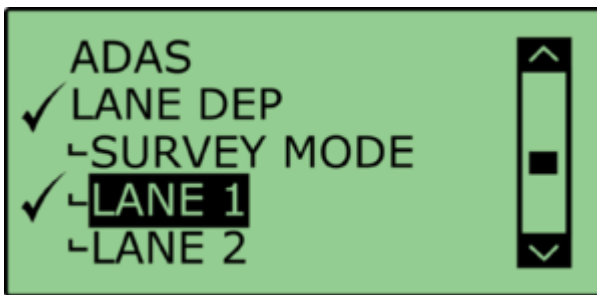

7. Then click on the '**SET LANE**' option.



8. Highlight and select the '**SET PNT 1**' option to mark this first point.

9. Move the Tripod and vehicle to another position point on the line, preferably >50 m (further apart is better) from the start position and click '**SET PNT 2**'.

**If you believe that the painted Lane edge has been painted perfectly then you can use just two points to describe the line. Go to point 11.**



**If you believe that the line does have some acceptable fluctuations but you want to survey these as best as possible, then you can set more than two points to accurately map the line. Go to point 10.**

10. Move the Tripod and vehicle to the another position point on the line preferably >50 m from the last position and enter this position as the next point, e.g '**SET PNT 3**'.

11. After setting the last point click on '**BACK**' to return to the main menu.  
**Repeat this procedure for any other test lines that you have up to a maximum of 3 lines.**

---

## Pre-Test Configuration

### Corner Position

In accordance with the NHTSA “Lane Departure Warning System NCAP Confirmation Test December 2008, “Lane departure is said to occur when any part of the two dimensional polygon used to represent the test vehicle breaches the in board lane line edge. In the case of tests performed in this procedure, the outside front corner of the polygon will cross the line edge first”.

“The corners of the polygon are defined by the lateral and longitudinal locations where the plane of the outside edge of each tire makes contact with the road. This plane is defined by running a perpendicular line from the outer most edge of the tire to the ground.”



The following provides a guide to setting the two front left and right measurement positions.

Connect the VBOX equipment within the vehicle as shown in [Lane Departure Test Schematic](#)

### Automatic Corner Position

1. Within the 'LANE DEP' option of VBOX Manager select '**CORNER POS**'.

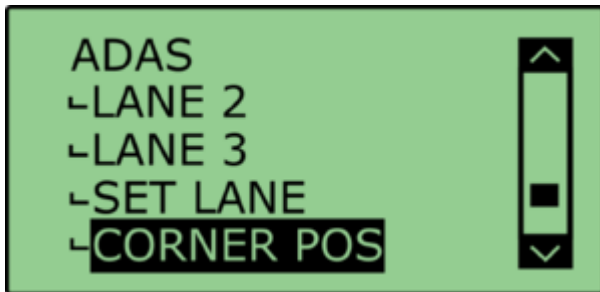

2. With the front left corner of the vehicle placed over the initial reference point of Lane 1 and facing in the same direction as the line was set, select '**SET FL POS**'.

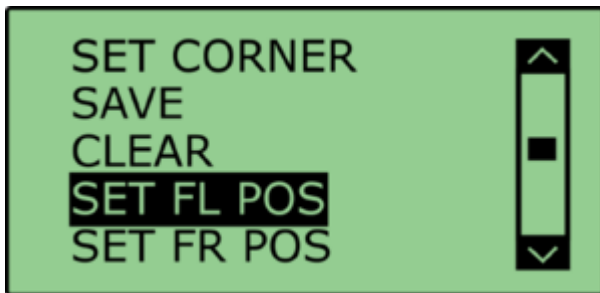

3. To automatically set the corner position, select '**AUTO SET**'.



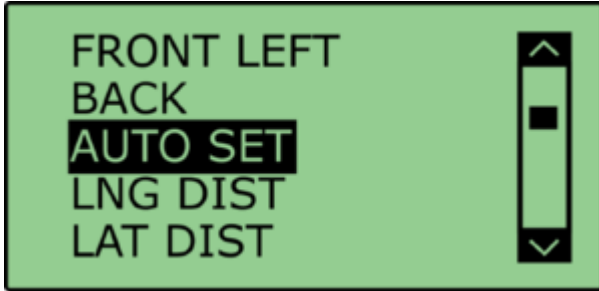

4. Repeat steps 2-3 for FR, RL and RR as required.

### Manual Corner Position

When using the down sampled survey lane as a reference lane it is not possible to use the auto corner position function within VBOX Manager. In this instance it is necessary to manually enter the offsets into VBOX Manager.

1. Within the 'LANE DEP' option of VBOX Manager select '**CORNER POS**'.

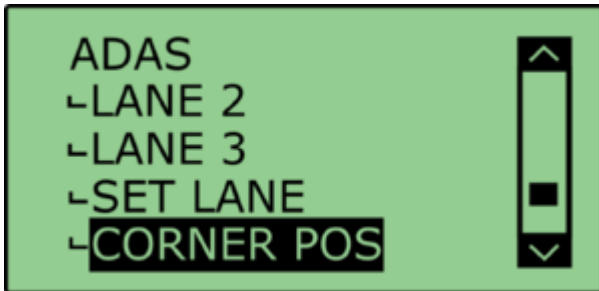

2. Select '**SET FL POS**'.

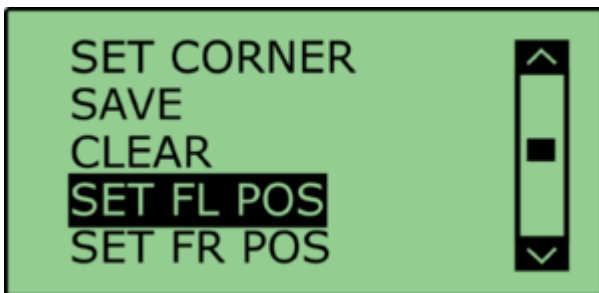

3. To manually set the corner position select 'LNG DIST'.

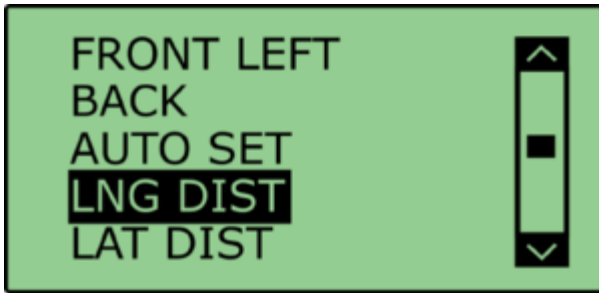

4. Enter the 'LNG DIST' value in accordance with the following orientation:

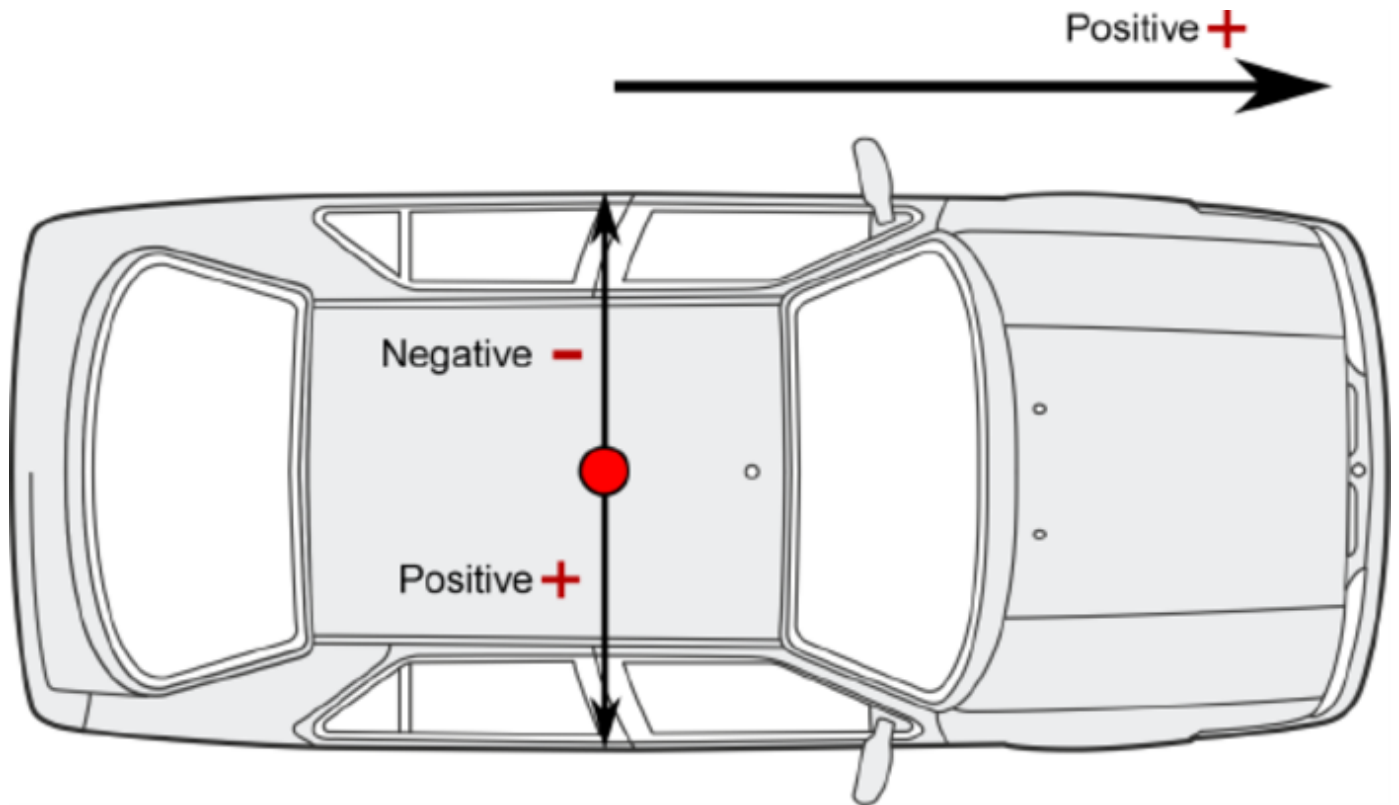

*Note: The corner position must be in-front of the GPS antenna, i.e. a positive longitude.*

5. Repeat step 4 but for the 'LAT DIST'.

6. Repeat steps 2-5 for FR, RL and RR as required.



## Saving and Loading Corner Positions

Once corner positions have been set in VBOX Manager, they can be saved as a .vbc file and recalled later for repeatability.

**If you have .vbc files saved using pre VBOX firmware version 1.2.5, you will need to load these back in, and re-save out to make them compatible with latest firmware.**

*Note: For corner positions to be recalled accurately, the GPS antenna location on the car and the location of the Base Station GPS antenna must be identical as when the data was recorded.*

1. Within the '**LANE DEP**' option of VBOX Manager, select '**CORNER POS**' and then select '**SAVE**'.

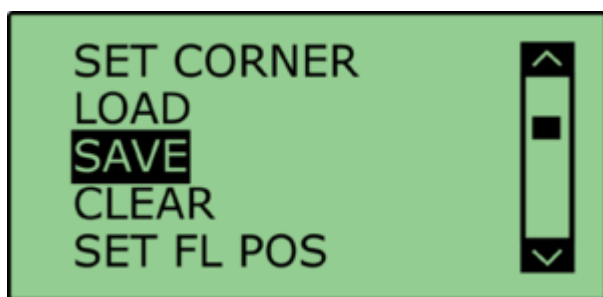

2. Within the '**SAVE**' menu select the appropriate file name. This will be saved onto the CF card as a .vbc file.

3. To load a .vbc file containing offset data, select the '**LOAD**' option from the '**CORNER POS**' menu. This will present a list of saved .vbc files containing corner position offsets. Selecting the appropriate file loads these values into the VB3iSL-RTK firmware and allows for range values to be calculated to these corner positions.

## Heading Smoothing

There are two configurable variables linked to heading smoothing; 'Smoothing Distance' and 'Speed Threshold'. Due to the nature of the vehicle separation measurement and calculation process many channels are derived using the heading of the vehicle which can be noisy. To overcome this heading can be smoothed with a dynamic smoothing routine.

Under the '**LANE DEP**' option within the '**ADAS**' menu, select '**SMOOTHING**'.





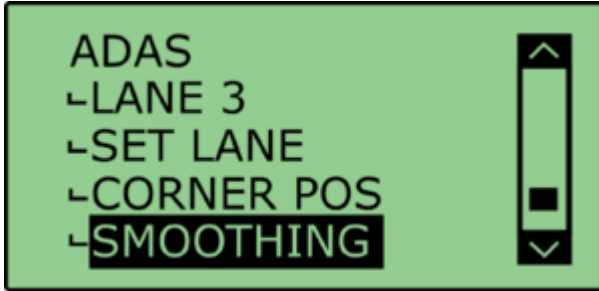

### Smoothing Distance

The smoothing routine is calculated between the current and previous samples. The previous sample to be used is determined using a Smoothing Distance, this results in a variable number of samples used to determine the smoothing level on the heading; the lower the speed the more samples that are used. With 100 Hz logging and a smoothing distance of 1.1 m at 80 km/h, the heading is calculated over the previous 5 samples, whilst at 15 km/h the heading is calculated over the previous 26 samples.

Select '**SMOOTHING DIST**' and enter the smoothing option between 0.00 m and 2.00 m. **A smoothing distance of 2.00 m is recommended.**

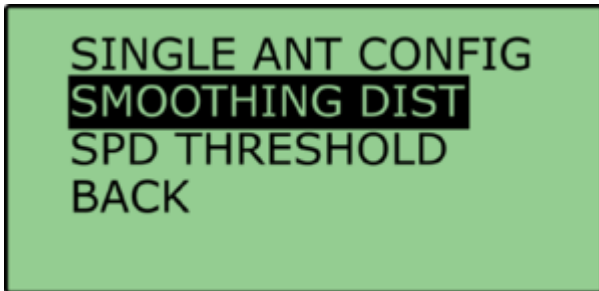

### Speed Threshold

Due to the large number of samples in a small distance when travelling at low speed the heading channel can become very noisy, this in turn results in many of the Vehicle Separation channels becoming noisy at low speed. When the speed threshold is set to a certain speed the heading is locked when the vehicle travels under that speed.

1. To set the speed threshold repeat steps above in 'Heading Smoothing', then select '**SPD THRESHOLD**' and enter the speed threshold option.





SINGLE ANT CONFIG  
SMOOTHING DIST  
**SPD THRESHOLD**  
BACK

2. We recommend a Speed Threshold of 5 km/h.



## LDWS - Video

The addition of the Video VBOX to the VB3i ADAS system adds synchronised video logging with the added benefit of overlaid data at static images.

Video is often required to be recorded as part of regulation requirements.

For Lane departure the ability to add static images offers the ability to visually gauge wheel to lane edge distances.



# Racelogic Lane Departure

Ruler graphic overlaid live onto the recorded video



This guide will explain the process to create accurate on-screen gauges for showing the distance from a vehicle front edge to the “road edge”.

## Example scene



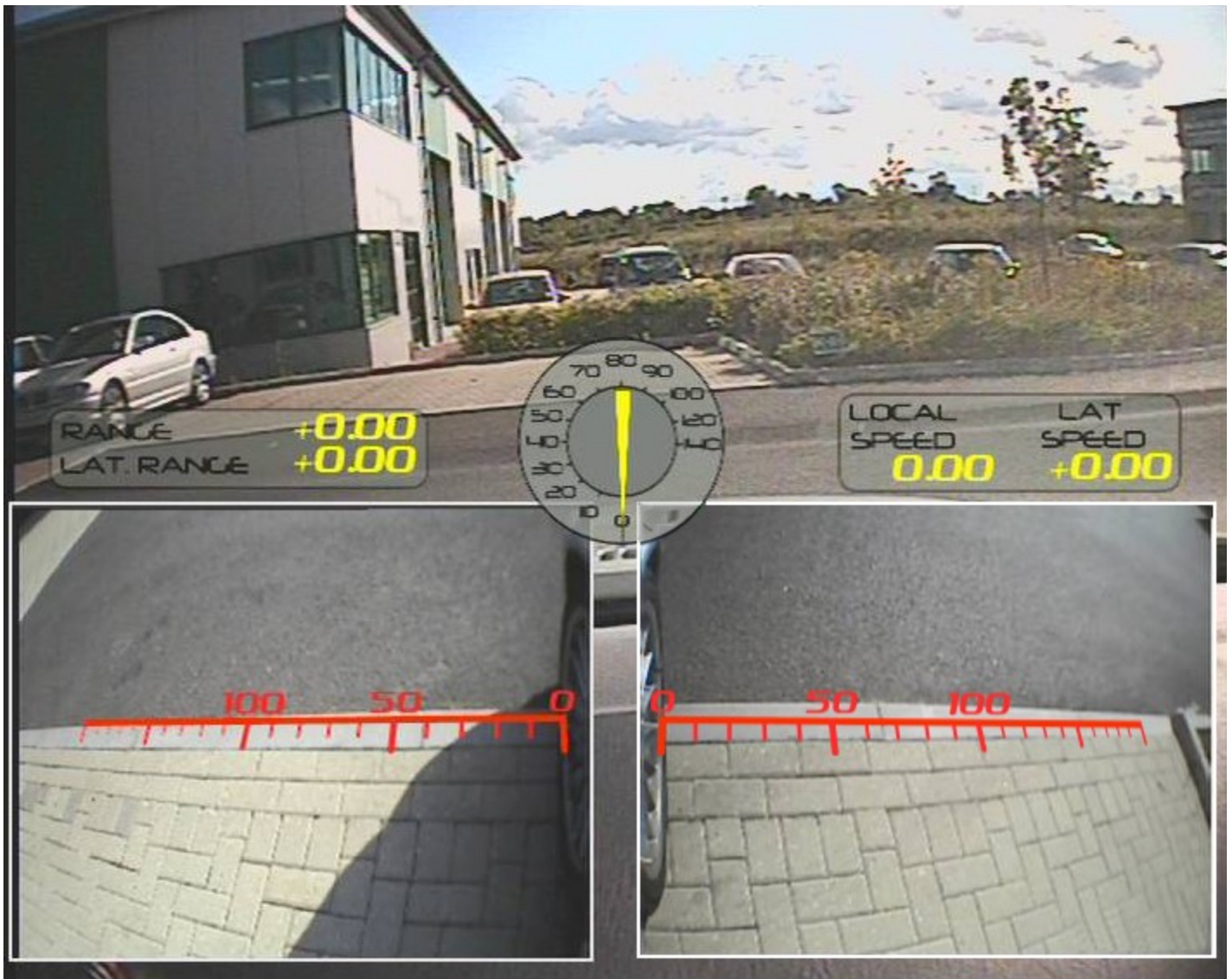

## Configuration procedure

- Set the Video VBOX up on the test vehicle, with both side mounted cameras aligned as required. Use the supplied Camera preview unit to ensure correct camera alignment, as shown above. The supplied extendable suction mounted camera mounts will allow the cameras to be mounted as shown in the picture below. Place your clearly marked calibration rods at the front wheel positions at exact 90 degrees to the body of the car. These will act as the proof of distance measurement.

**Do not move the vehicle, the cameras or the marked rulers until the end of the following process.**







- Connect your Laptop computer via USB to the Video VBOX, run Video VBOX setup software on the laptop.



- Select the software option “Download preview into background”, the software will then take a snap shot from each camera and save it into the background of the Video VBOX software screen.
- Now, a ruler image can be created using the line style simple shape elements within VVB Setup.

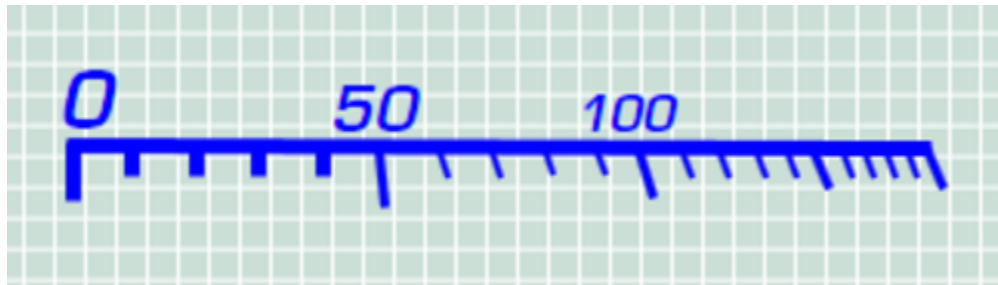
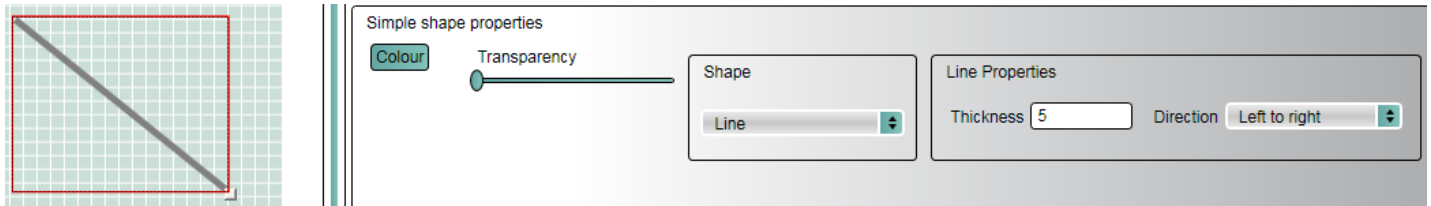

- Alternatively, take a “print screen” image of your Video VBOX software screen to use in a third party image manipulation software.
- Paste the captured “print screen” image into a suitable graphics package like Photoshop or Inkscape, ensuring that pixel ratios are maintained.
- Then draw the new ruler image over the top of the ruler line in the captured video image.
- You will then be able to create a custom ruler image calibrated to the camera positions on your test vehicle like the right hand gauge shown below.



- Save these new gauges in a PNG format.
- Go back into the Video VBOX setup software and select the option Elements – New - Static image.
- This will create space for a new Static image in your scene
- Got to the ‘Static Image properties’ section of the software and click load to load in one of your new gauge images.
- Then move this gauge into position in your corresponding picture in picture, aligning it with the video image of the ruler line.
- Repeat this process for the other camera picture in picture position.



- Then save this scene.
- Reconnect to your Video VBOX in the test car and download the new scene into the video VBOX.
- Without moving the vehicle or the rulers record a few seconds of video to confirm that the on screen gauges and the markings on the Rulers line up. As shown in the single camera image below.

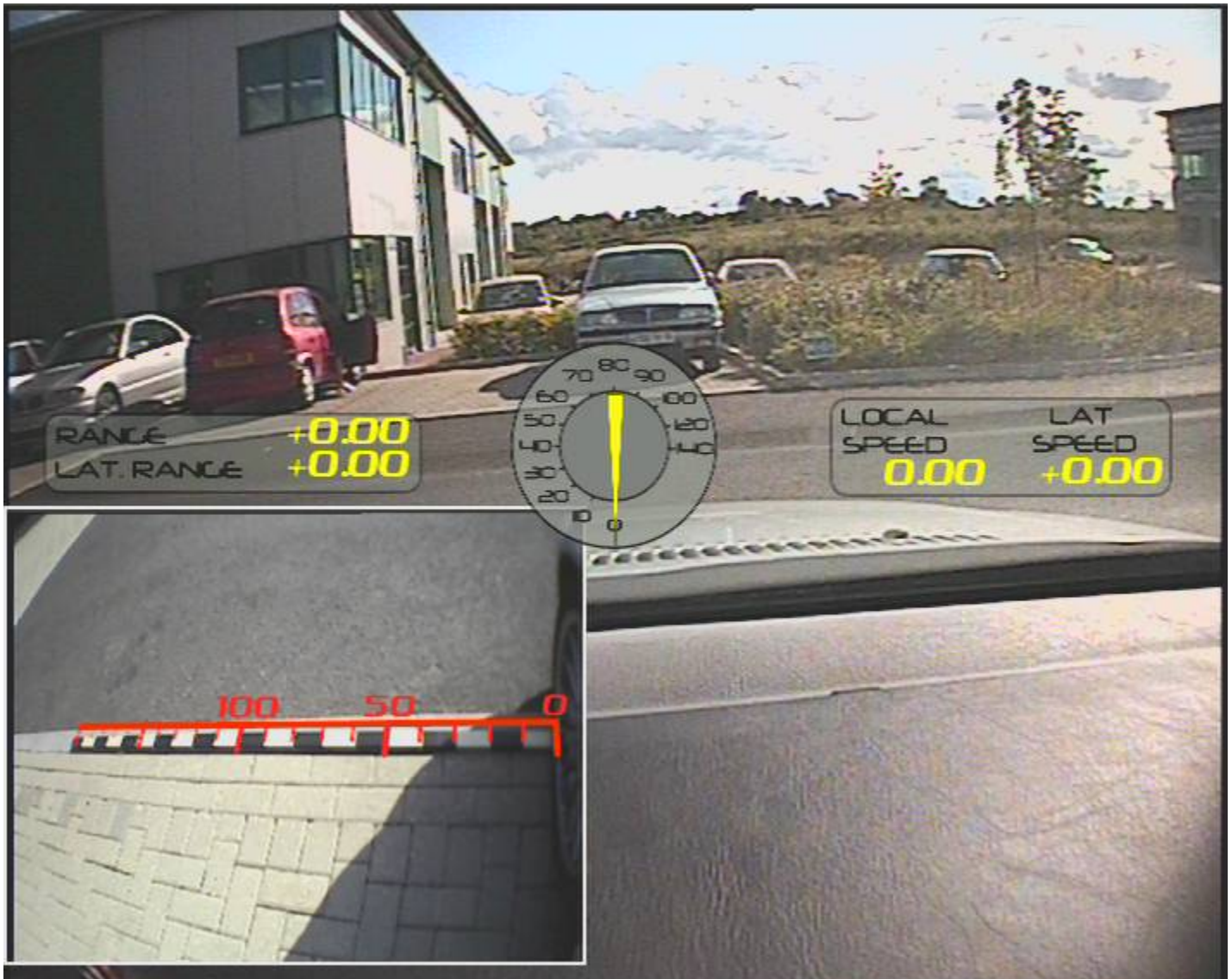

- Once confirmed, the marked rulers can be removed and the lane departure test conducted.



## Park Assist - Straight Lane

---

### Hardware Configuration

The following diagrams show the recommended hardware configuration for each vehicle. The items greyed out are not essential but many customers may find them beneficial.

**Please ensure that all vehicle antennas are correctly positioned and connected.**





# Lane Survey Configuration

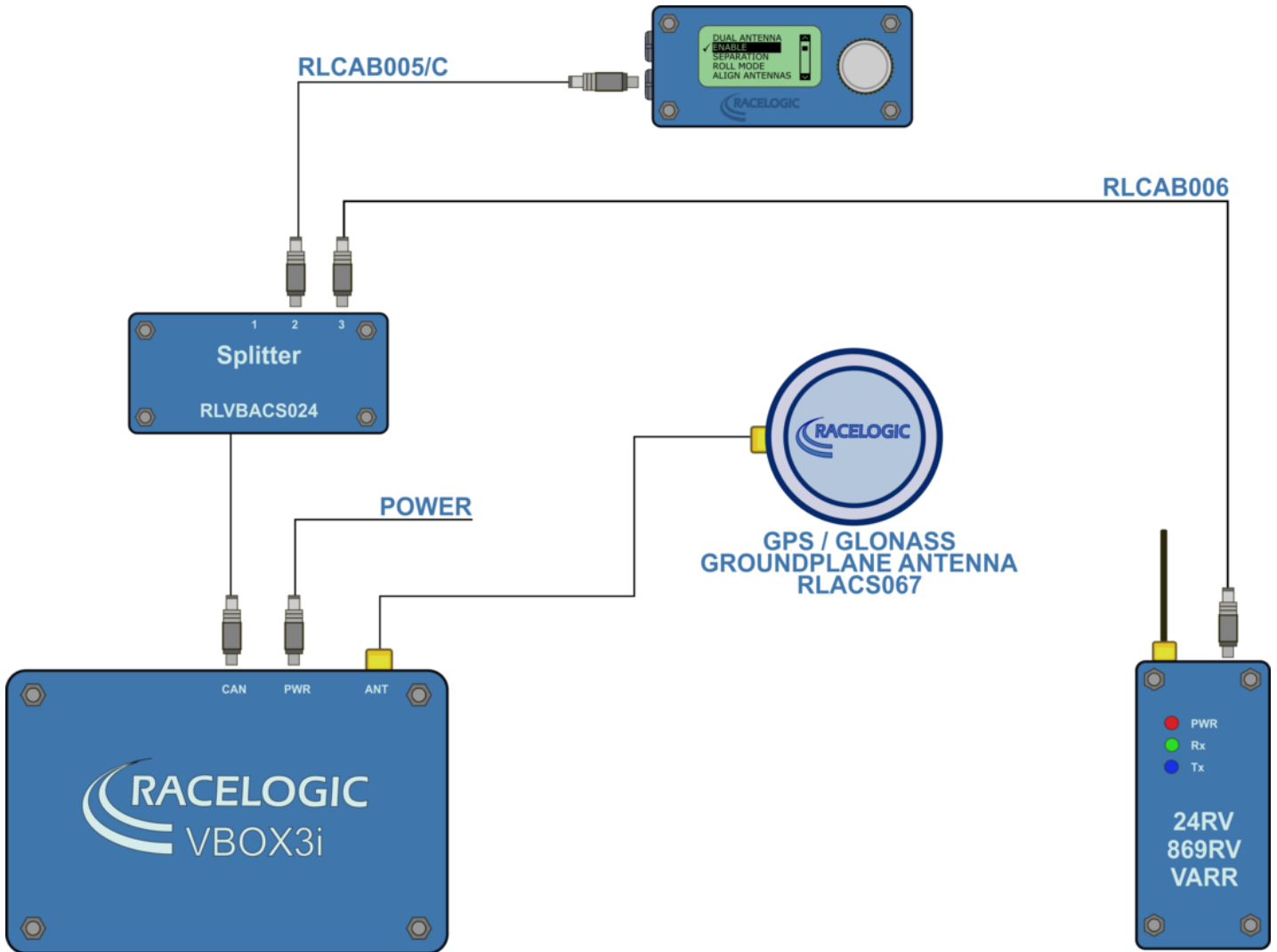

# Park Assist Test Schematic

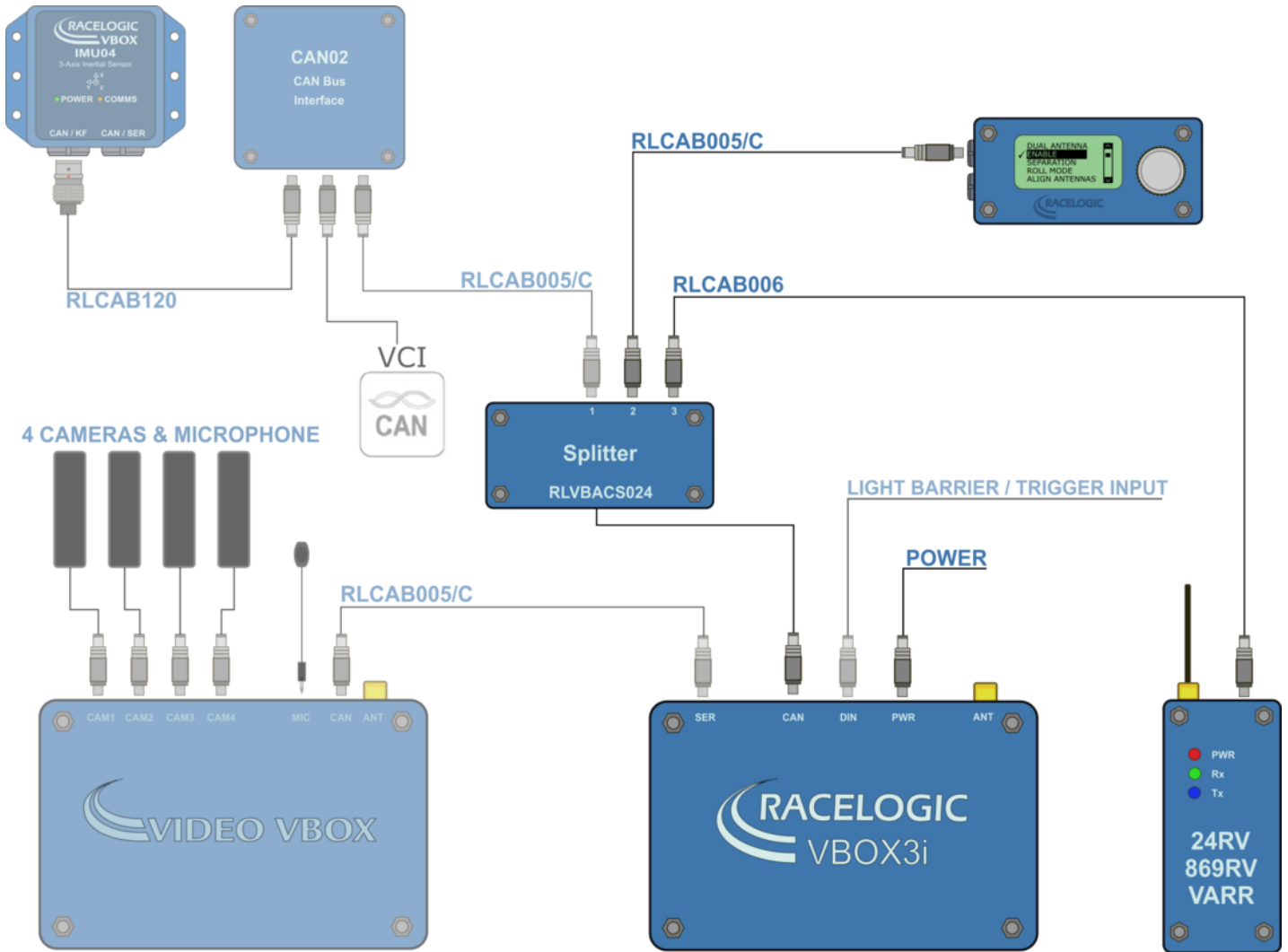

---

## VBOX Configuration

### Base Station

A static Base Station must be used for the VBOX to gain the RTK 2 cm positional accuracy. This is required for the lane survey as well as during testing.

Moving Base cannot be used because a static Base Station is the only way to create a reference to a static location, which then allows measurement to other static objects like lane edges.

See the [Base Station user guide](#) for Base Station installation.

**Important Note: The Base Station GPS antenna must be in exactly the same location for lane survey and for subsequent testing. It is also good practice to save the location into the Base Station memory.**

Confirm that the VBOX unit is in RTK 'Fixed' DGPS status, indicated by the following:



The VBOX front panel will indicate the required RTK Fixed status, with the illumination in green of the diff light.



A VBOX Tools live window set to Solution Type shows 'RTK Fixed'.



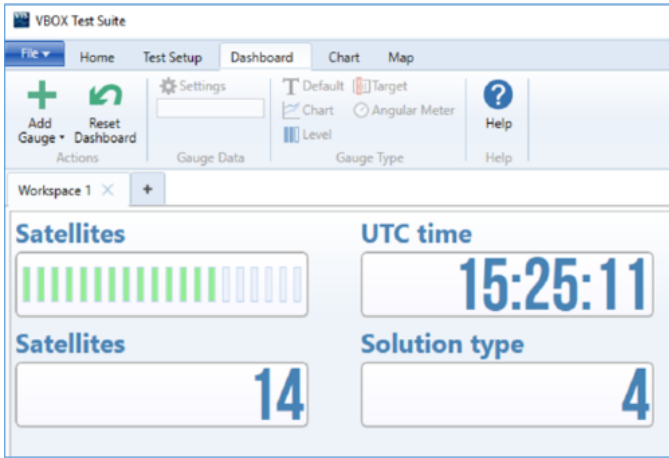

A VBOX Test Suite live Workspace window set to Solution type shows '4' (RTK fixed).

## Process Summary

Using the Racelogic ADAS systems there are two setup methods dependent on the straightness of the test lane edge. The following schematic shows the options for determining Lane Departure Warning parameters.

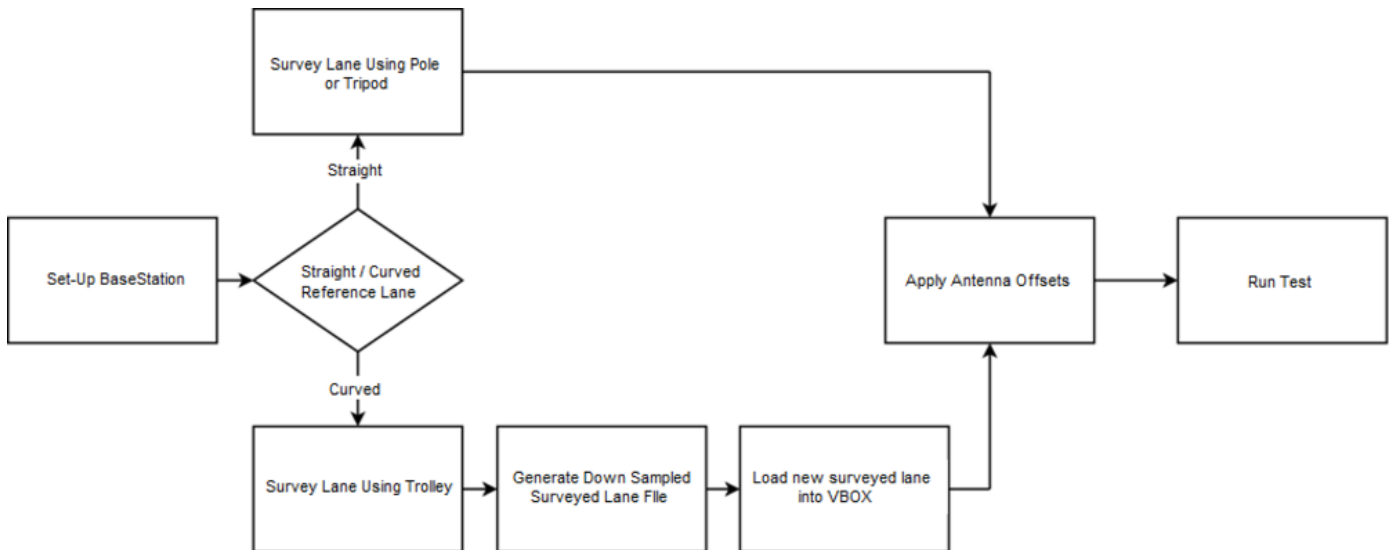

## Hardware Configuration – Lane Survey

1. Connect the VBOX equipment as shown in [Lane Survey Configuration](#) with the GPS antenna mounted on top of a survey pole (RLACS168).
2. Enter the setup menu of VBOX Manager.
3. Select the '**VBOX**' option.
4. Select '**LOG RATE**' and set the rate to 100 Hz, then select '**BACK**' to return to the '**VBOX**' setup menu.

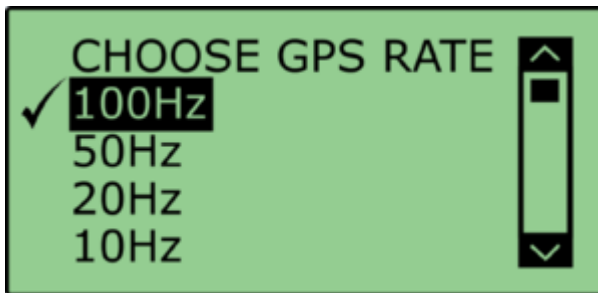

5. Select '**DYNAMICS**' and set the dynamic mode to '**NORMAL**', this Dynamics mode is best for ADAS tests, return to the '**VBOX**' setup menu.

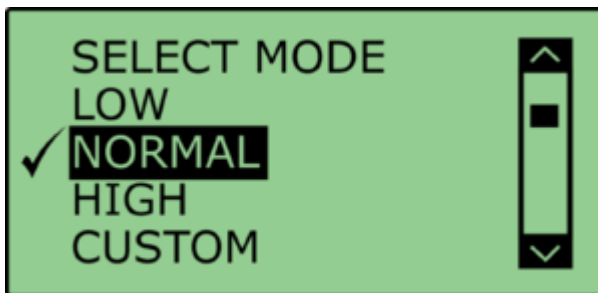

6. Select '**DGPS**' and set the DGPS mode to the same 2 cm mode that the Base Station is set to, return to the '**VBOX**' setup menu.

For further info on RTK modes see [RTK Configuration](#).

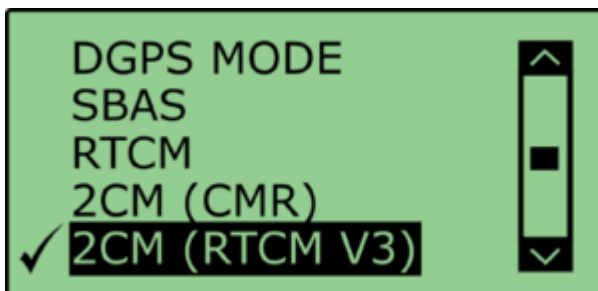

7. Select 'DGPS RS232 Rate' and select the appropriate settings for your radios, return to the VBOX setup menu.

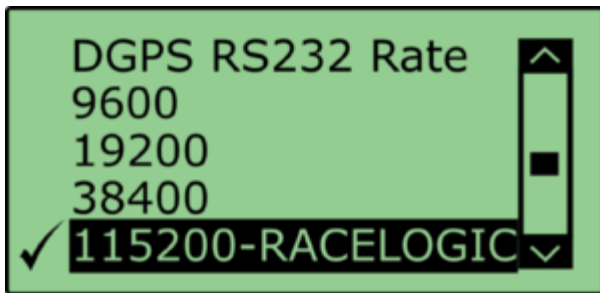

**Note:** To ensure that the VBOX receives the DGPS correction signal, the correct RS232 rate must be set. All Racelogic blue boxed radios use 115200 kbit/s, Satel grey boxed radios use either 19200 kbit/s or 38400 kbit/s.

## Lane Survey

Within the Racelogic ADAS firmware there are two ways for surveying a lane. If the test is intended for straight lanes only then a simple point-to-point lane (utilising up to 8 points along the lane) can be surveyed using a VBOX 3i RTK and a survey pole as described in 'Straight Line' section below.

If the test lane is not straight enough to be represented by 8 points then an alternative method can be used to obtain the reference lane data. This method requires the use of a Survey Trolley (RLACS173-XXX where XXX represents the frequency of the Base station). When using the Survey Trolley data is recorded at 10 Hz and provides a more accurate representation of a lane on a curved road. Please see the Survey Trolley instruction manual for instructions on how to assemble the equipment.

## Multiple Lanes

It is possible to load three surveyed lanes into the VBOX which can then be individually selected via VBOX Manager.

It is **NOT** possible for the VBOX to make measurements to more than 1 lane edge at a time.

For 2 cm positional accuracy during the Lane Departure Warning Test an RTK Base Station is required.



## Straight Line

1. Connect the VBOX equipment as shown in [Lane Survey Configuration](#).
2. Place the Vehicle near to the edge of the first lane that you plan to survey.
3. Place the GPS antenna connected to the vehicle system onto the supplied Tripod or a suitable Survey pole.
4. Place the supplied tripod over the Lane edge and use a Plumb line hanging from underneath the GPS antenna to ensure that the GPS antenna is directly over the road side edge of the lane edge.
5. Mark this point on the Ground with paint or Sticky tape, as you will need to come back to it if you wish to Auto set the Antenna offsets.



6. On VBOX Manager go to the '**LANE DEP**' menu options and select '**LANE 1**'.

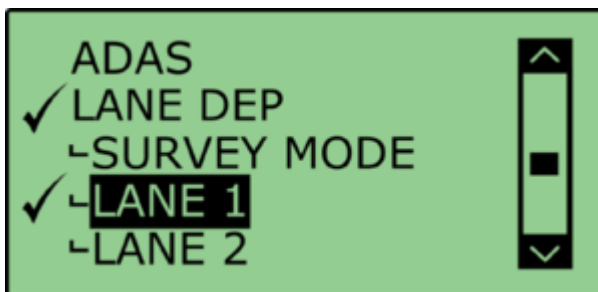



7. Then click on the 'SET LANE' option.



8. Highlight and select the 'SET PNT 1' option to mark this first point.

9. Move the Tripod and vehicle to another position point on the line, preferably >50 m (further apart is better) from the start position and click 'SET PNT 2'.

**If you believe that the painted Lane edge has been painted perfectly then you can use just two points to describe the line. Go to point 11.**



**If you believe that the line does have some acceptable fluctuations but you want to survey these as best as possible, then you can set more than two points to accurately map the line. Go to point 10.**

10. Move the Tripod and vehicle to the another position point on the line preferably >50 m from the last position and enter this position as the next point, e.g 'SET PNT 3'.

11. After setting the last point click on 'BACK' to return to the main menu.  
**Repeat this procedure for any other test lines that you have up to a maximum of 3 lines.**





---

## Pre-Test Configuration

### Corner Position

In accordance with the NHTSA “Lane Departure Warning System NCAP Confirmation Test December 2008, “Lane departure is said to occur when any part of the two dimensional polygon used to represent the test vehicle breaches the in board lane line edge. In the case of tests performed in this procedure, the outside front corner of the polygon will cross the line edge first”.

“The corners of the polygon are defined by the lateral and longitudinal locations where the plane of the outside edge of each tire makes contact with the road. This plane is defined by running a perpendicular line from the outer most edge of the tire to the ground.”

The following provides a guide to setting the two front left and right measurement positions.

### Automatic Corner Position

1. Within the '**LANE DEP**' option of VBOX Manager select '**CORNER POS**'.

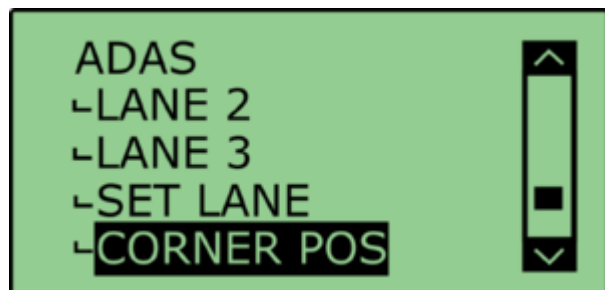

2. With the front left corner of the vehicle placed over the initial reference point of Lane 1 select '**SET FL POS**'.

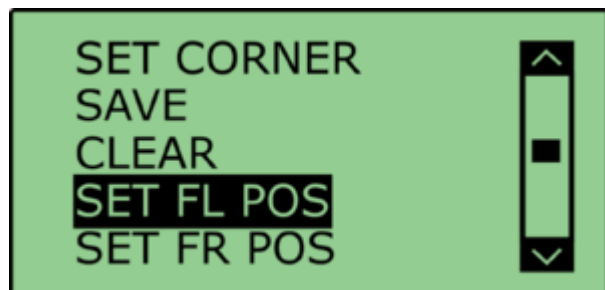

3. To automatically set the corner position, select '**AUTO SET**'.

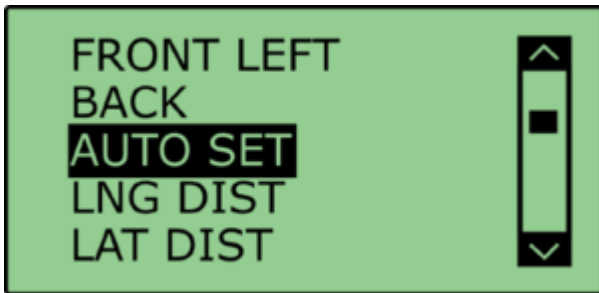

4. Repeat steps 2-3 for FR, RL and RR as required.

### Manual Corner Position

When using the down sampled survey lane as a reference lane it is not possible to use the auto corner position function within VBOX Manager. In this instance it is necessary to manually enter the offsets into the VBOX Manager.

1. Within the 'LANE DEP' option of VBOX Manager select '**CORNER POS**'.

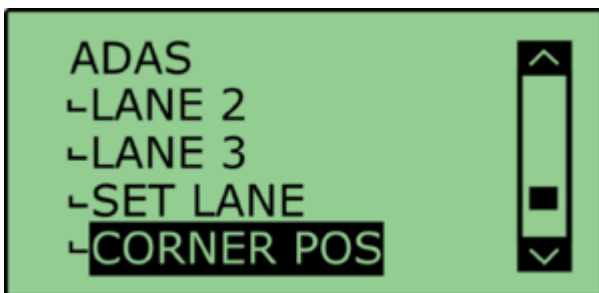

2. Select '**SET FL POS**'.

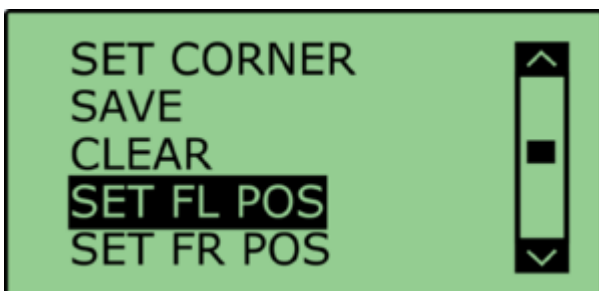

3. To manually set the corner position select '**LNG DIST**'.

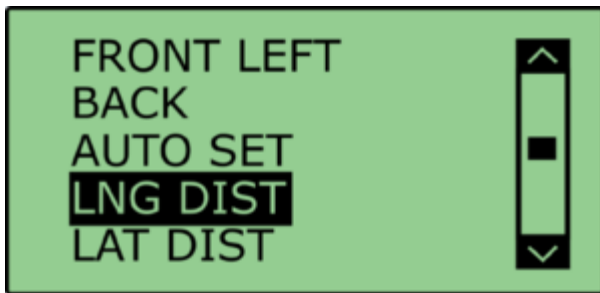

4. Enter the 'LNG DIST' value in accordance with the following orientation:

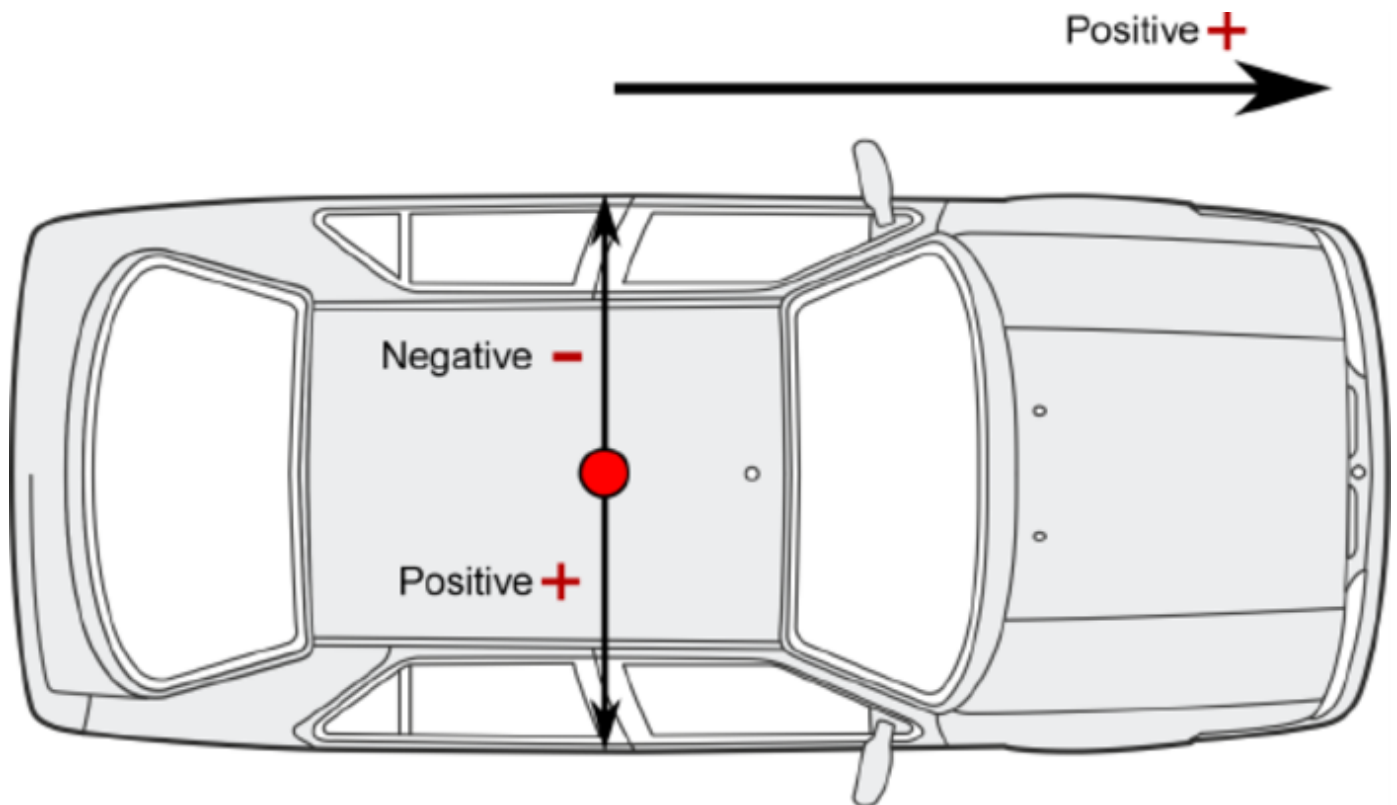

*Note: The corner position must be in-front of the GPS antenna, i.e. a positive longitude.*

5. Repeat step 4 but for the 'LAT DIST'.

6. Repeat steps 2-5 for FR, RL and RR as required.



## Saving and Loading Corner Positions

Once corner positions have been set in VBOX Manager they can be saved as a .vbc file and recalled later for repeatability.

*Note: For corner positions to be recalled accurately, the GPS antenna location on the car and the location of the Base Station GPS antenna must be identical as when the data was recorded.*

1. Within the '**CORNER POS**' option of the '**ADAS**' menu select '**SAVE**'.

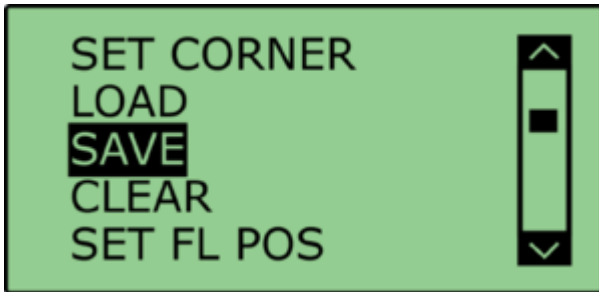

2. Within the '**SAVE**' menu select the appropriate file name. This will be saved onto the CF card as a .vbc file.

3. To load a .vbc file containing offset data, select the '**LOAD**' option from the '**CORNER POS**' menu. This will present a list of saved .vbc files containing corner position offsets. Selecting the appropriate file loads these values into the VB3iSL-RTK firmware and allows for range values to be calculated to these corner positions.

## Heading Smoothing

There are two configurable variables linked to heading smoothing; 'Smoothing Distance' and 'Speed Threshold'. Due to the nature of the vehicle separation measurement and calculation process many channels are derived using the heading of the vehicle which can be noisy. To overcome this heading can be smoothed with a dynamic smoothing routine.

Under the '**LANE DEP**' option within the '**ADAS**' menu, select '**SMOOTHING**'.

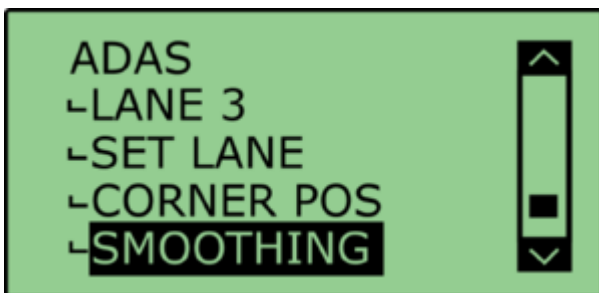

## Smoothing Distance

The smoothing routine is calculated between the current and previous samples. The previous sample to be used is determined using a Smoothing Distance, this results in a variable number of samples used to determine the smoothing level on the heading; the lower the speed the more samples that are used. With 100 Hz logging and a smoothing distance of 1.1 m at 80 km/h, the heading is calculated over the previous 5 samples, whilst at 15 km/h the heading is calculated over the previous 26 samples.

Select '**SMOOTHING DIST**' and enter the smoothing option between 0.00 m and 2.00 m. **A smoothing distance of 2.00 m is recommended.**

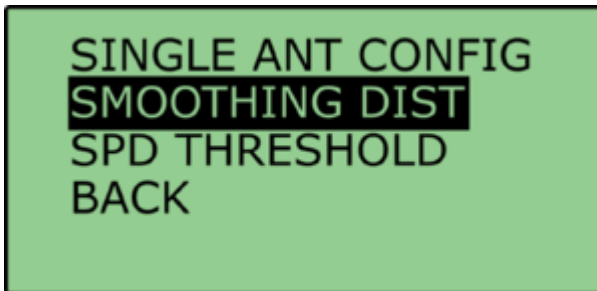

## Speed Threshold

Due to the large number of sample in a small distance when travelling at low speed the heading channel can become very noisy, this in turn results in many of the Vehicle Separation channels becoming noisy at low speed. When the speed threshold is set to a certain speed the heading is locked when the vehicle travels under that speed.

1. To set the speed threshold repeat steps above in 'Heading Smoothing', then select '**SPD THRESHOLD**' and enter the speed threshold option.

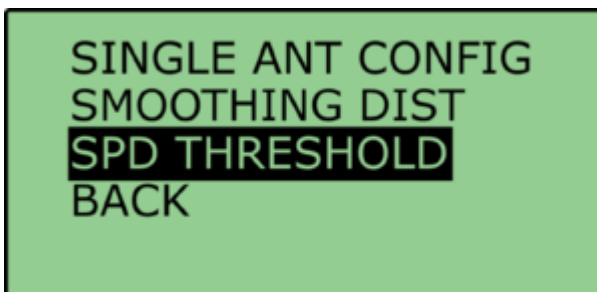

2. We recommend a Speed Threshold of 5 km/h.



## VBOX File Processor - Park Assist

VBOX File Processor Parking Plugin is designed to meet ISO regulation **204/WG14 ISO16787** 'Assisted Parking Systems (APS) — parking with reference to other parked vehicles'.

The screenshot displays the VBOX File Processor Parking Plugin interface. Key components include:

- Available Process Blocks:** A sidebar on the left with options like ADAS, Parking Assist, Interruption, Intersection, Lane Data Generation, Lane Departure, and Vehicle Separation.
- Input File:** Located at the top, showing the path 'C:\Users\User\Desktop\VBOX0015.vbo'.
- Selected Process Blocks:** The main workspace containing:
  - Add measurements to:** Checkboxes for 'All sides', 'Nearest side', 'Entrance Points', and 'Minimum distance'.
  - Bay Sides:** A table with columns for File Name, Colour, Dashed, Thickness, Filter, and Clear. It lists 'Load Side 1 (s1)', 'Load Side 2 (s2)', and 'Load Side 3 (s3)'.
  - Entrance Points:** A table with columns for Point ID, X, Y, and W. It lists 'e1' and 'e2'.
  - Vehicle Measurement Points:** A table with columns for Point ID, X Offset, Y Offset, and a color dropdown. It lists 'p1' through 'p5'.
  - Maps:** Two maps showing 'Bay Sides and Entrance Points Map' and 'Vehicle Measurement Points Map'.
  - Output:** A section for 'True Heading Smoothing Level' and a grid of checkboxes for various range and entrance point options.
  - Output File:** A field at the bottom showing the processed file path 'C:\Users\User\Desktop\VBOX0015\_Processed.vbo'.

## Requirements

Input source files must contain true heading information in order to be compatible. This means that the Parking Assist plugin will work with files from VB3i SL RTK units only.

An error message will show if the true heading channel is missing from input file, and the software won't allow the user to process a file.



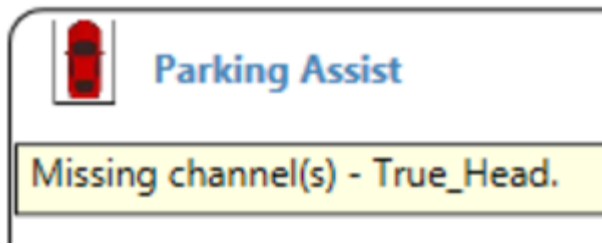

Smoothing can be added to the true heading channel if the raw input data is noisy. Here the user can set the number of samples the data channel is smoothed over – the default value is 5.

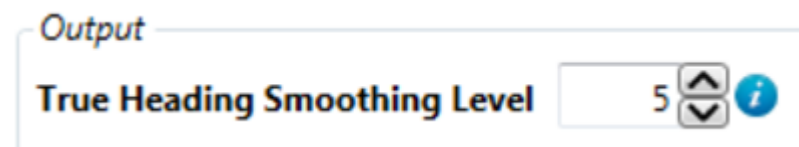

## Add measurements to

This section selects which channels are included in the resulting output file.

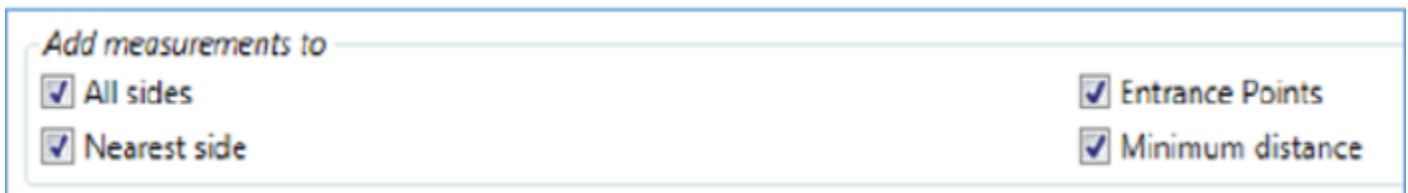

- All sides - Denotes that a measurement to each bay side should be added for each point on the vehicle.
- Nearest side - Denotes that a measurement to the nearest side should be added for each point on the vehicle.  
*Note: If all sides is also ticked, one of the sides will contain the same data as the nearest side channel for a given vehicle point.*
- Entrance points - Includes a measurement to both entrance points from each vehicle point.
- Minimum distance - Denotes that a single channel should be added containing the minimum vehicle point to bay side measurement (effectively the minimum distance from the vehicle to any side).

## Bay side configuration

Parking assist can be used to create any virtual 3 sided parking bay, for use with reverse or parallel parking tests.

A bay must be configured from 3 separate files that have to be plotted by the user. The user cannot create a bay from a single logged file.



Input files can be .vbo (VBOX), .vbc (lane departure), or .dbn (PB/DB/VBM).

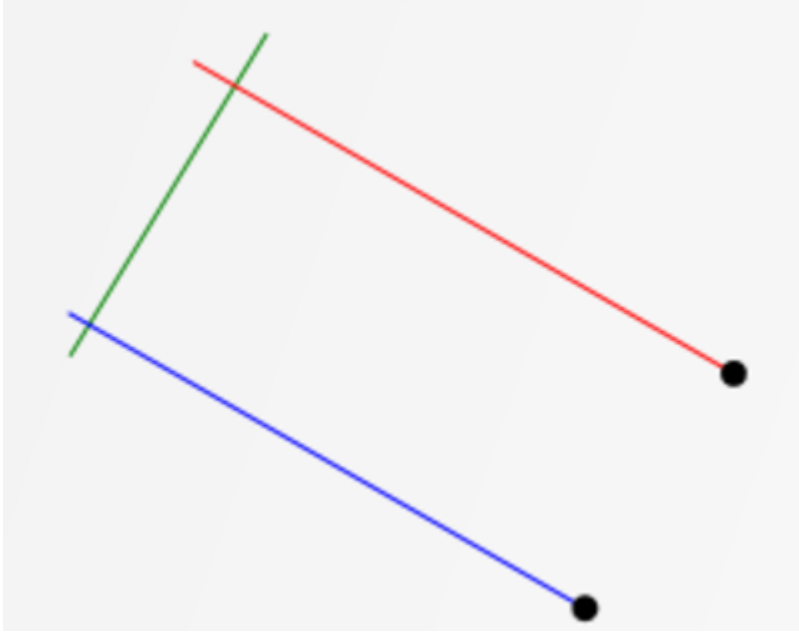

When a file with more than two position points is loaded, parking assist plugin will produce a line of best fit through the position points within the loaded file. This ensures the bay sides are straight.





When plotting (recording) a bay side, the user is required to extend the plot of the bay side past the corner point, so that there is a clear overlap. When configuring the sides of a bay, ensure the plotting of the bay starts from the entry point, and finishes past the intersection of the 'base' bay line.

The overlap of plotted lines is required as the software determines the 'base' of the bay as the side with 2 overlapping lines/intersections (green line in case picture to the right).

Once there are 3 overlapping lines the software will automatically determine 2 entry points for the lane, taking the furthest point from intersection. For this reason the customer should ensure they do not plot too far past the corner point of the lane.

Customers can use the 'bay sides and entrance points map' to visualise (check) the configured bay. Within here, the user is able to change the colour, appearance and define thickness of the visual representation. This is only a visual representation, and has no bearing on the actual result (i.e. thickness of line does not alter result).

*Bay Sides*

	File Name	Colour	Dashed	Thickness	Clear
<b>Load Side 1 (s1)</b>	B.VBC	<span style="color: green;">█</span>	<input type="checkbox"/>	1.0	<input type="checkbox"/>
<b>Load Side 2 (s2)</b>	L.VBC	<span style="color: red;">█</span>	<input type="checkbox"/>	1.0	<input type="checkbox"/>
<b>Load Side 3 (s3)</b>	R.VBC	<span style="color: blue;">█</span>	<input type="checkbox"/>	1.0	<input type="checkbox"/>

*Entrance Points*

e1 X -0.991450732051608 Y 51.989428239517 █

e2 X -0.991469321915346 Y 51.9894101451155 █

*Bay Sides and Entrance Points Map*



---

## Complex Shape configuration

In software version 1.13.19.853 and later it is possible to add complex shapes instead of straight lines for bay sides. This allows for testing when there are no parking bay lines and perhaps only vehicles.

In the example, 2 vehicles sides were surveyed and are located either side of the parking space of interest. It is important to turn the filter off so that details such as the wing mirrors can be included in the measurement distance calculations.

Please note that as there are no longer Entrance points, these channels will not be output in the processed files.

Bay Sides	File Name	Colour	Dashed	Thickness	Filter	Clear
Load Side 1 (s1)	VBOX0001.VBO	Red	<input type="checkbox"/>	1.0	<input type="checkbox"/>	<input type="checkbox"/>
Load Side 2 (s2)	VBOX0002.VBO	Blue	<input type="checkbox"/>	1.0	<input type="checkbox"/>	<input type="checkbox"/>
Load Side 3 (s3)						

Entrance Points

e1  
e2

Bay Sides and Entrance Points Map

---

## Vehicle measurement point configuration

The vehicle measurement points section allows the user to configure required vehicle measurement points.

There is no limit to the number of vehicle measurement points that can be set.

Points should be measured from the primary antenna as shown below.



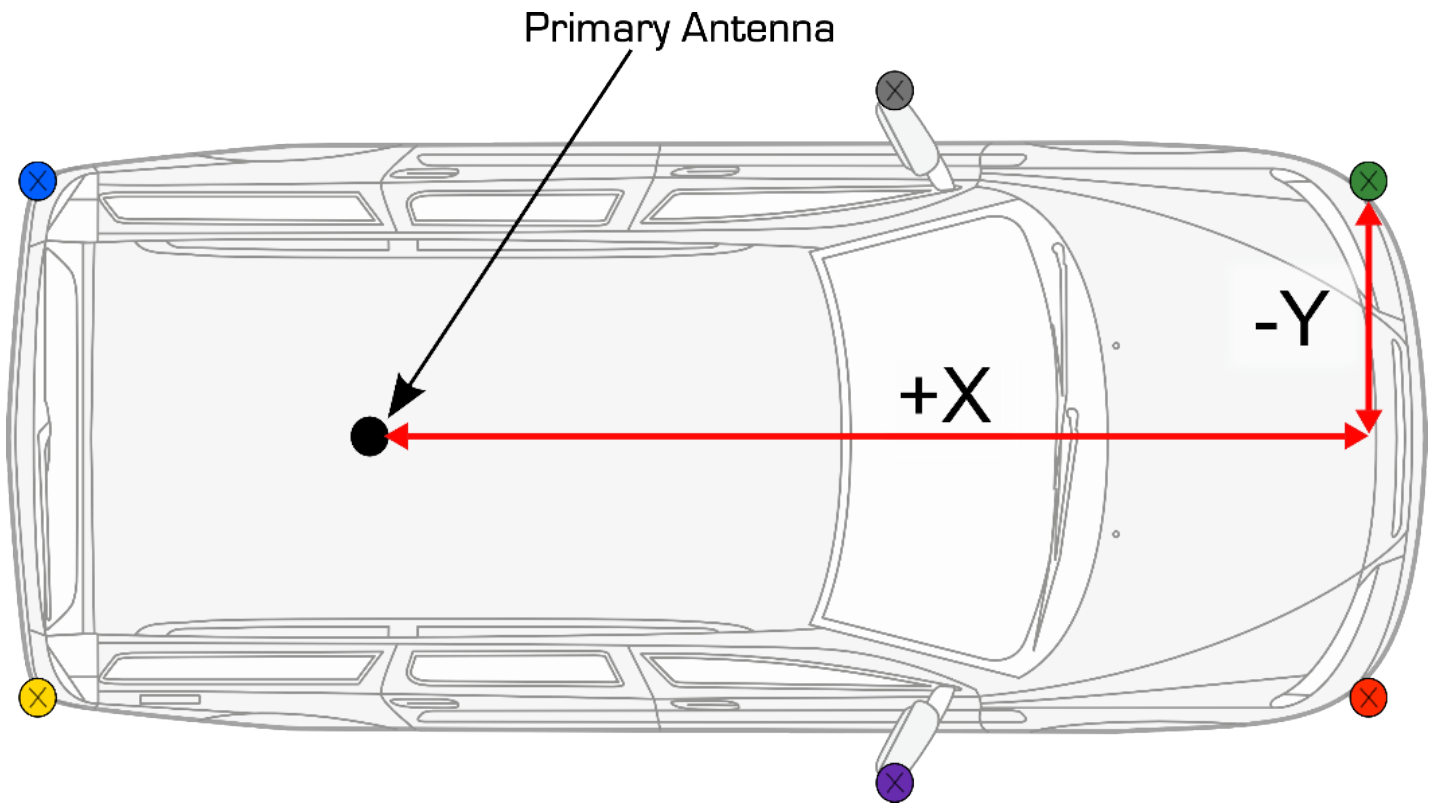

There is a 'vehicle measurement points' map to visualise the defined measurement points. As with bay sides the visual lines can be altered by colour to make it clear which point of the car the data (i.e. p1) is referencing in the processed result.

Each configured point will produce 5 range channels, two relative to entry points, and three relative to the bay sides.



Vehicle Measurement Points

Add

p1	X Offset	3.38	m	Y Offset	0.88	m		
p2	X Offset	-1.60	m	Y Offset	-0.88	m		
p3	X Offset	3.38	m	Y Offset	-0.88	m		
p4	X Offset	-1.60	m	Y Offset	0.88	m		
p5	X Offset	1.80	m	Y Offset	-1.15	m		



## Results

### e1 and e2 measurements

The 2 range measurements to bay side entrance points are direct straight line ranges between vehicle and entry point. The created channels will be labelled e1 and e2 relative to what is shown in the 'bay sides and entrance points' map. Two measurements in relation to the bay side entrance points will exist for every vehicle measurement point. For example, the p1\_e2 measurement is the distance between the second entry point and the first defined vehicle measurement point.

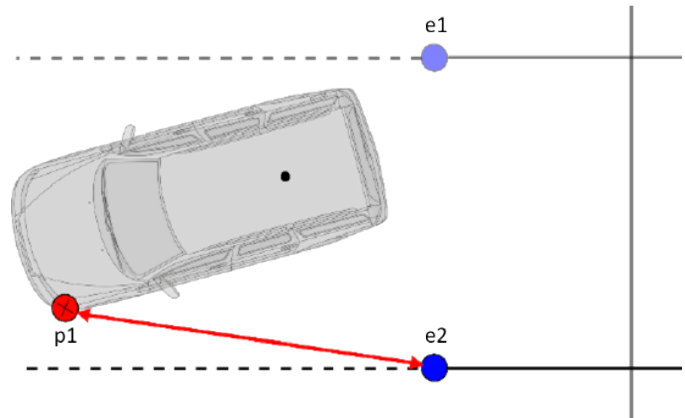

### s1, s2 and s3 measurements

The 3 bay side range measurements are calculated perpendicular to the bay side headings. The created channels will be labelled s1, s2 and s3 relative to what is shown in the 'bay side and entrance points' map. Three points in relation to the bay sides will exist for every vehicle measurement point. For example, the p1\_s3 measurement is the range of the first defined vehicle measurement point to bay side 3.

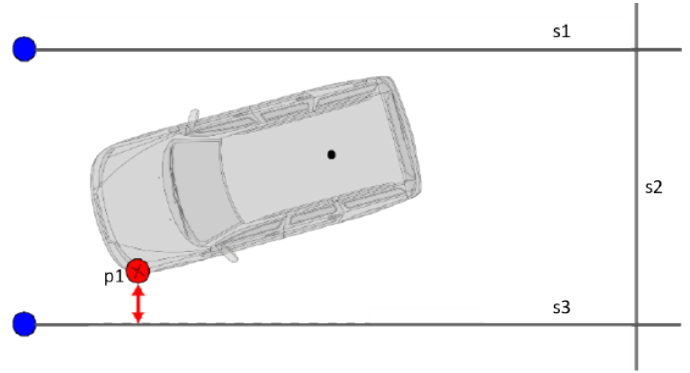

### Pre Software version 1.13.19.853

If the vehicle is outside of the configured bay, the bay side range measurements are calculated perpendicular to the extended bay side headings. Please note that as all range values are absolute values, they have no signing.

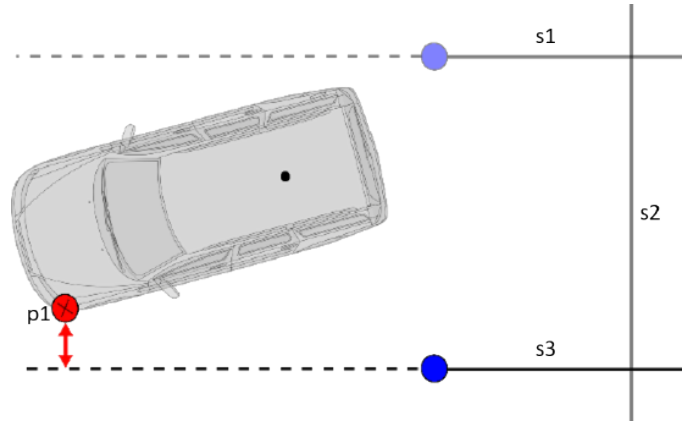

### Software version 1.13.19.853 and later

If the vehicle is outside of the configured bay, the bay side range measurements are calculated to the closest bay side point (i.e. the entrance point).

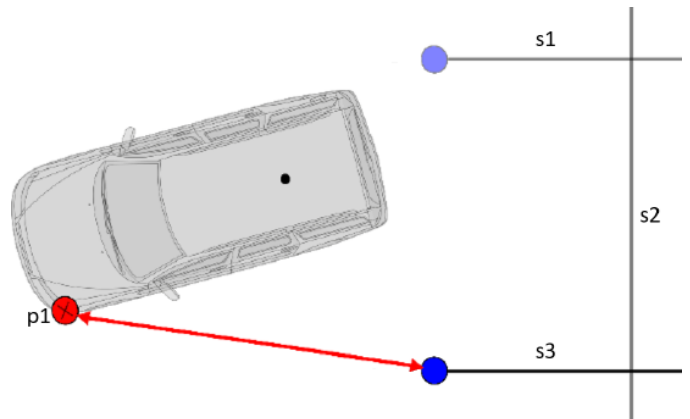

*Note: As all range values are absolute values, they have no signing.*



## Configuration and Processing

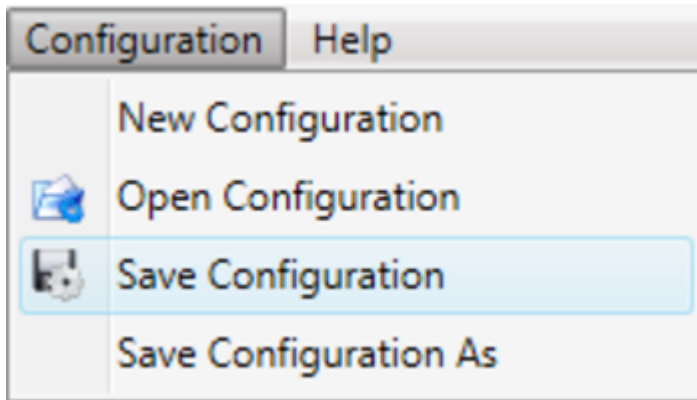

Combined bay sides and vehicle measure point configuration can be saved and reloaded at later date, using configuration/save configuration. Note that plugin settings are saved as a whole file, so separated vehicle measurement points and bay side profiles cannot be loaded.

As the plugin uses true heading, all range reference values will remain valid whether the vehicle is driving towards, or moving away from the bay.

Prior to processing the files, the user is able to alter what channels are processed, along with changing the naming conventions to make them suit their own needs.

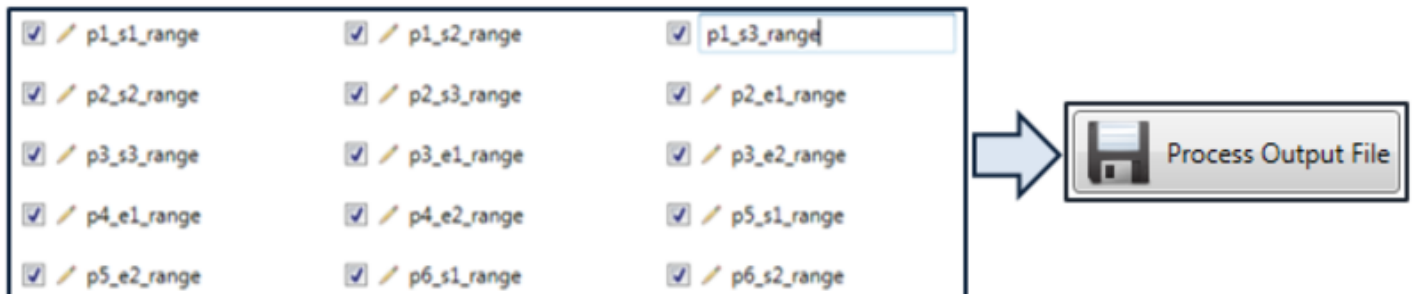

---

## Licensing

All process blocks within VBOX File Processor are free of charge. However, ADAS plugins require 'free' registration.



## TSR - Traffic Sign Recognition Testing (Multi Static Point)

The VBOX can track up to 100 static points and report precise positions and angles to these targets which is used when validating Traffic Sign Recognition systems.

---

### Enabling Multi Static Point Mode

1. Using 'VBOX Manager' enter the '**SETUP**' menu.

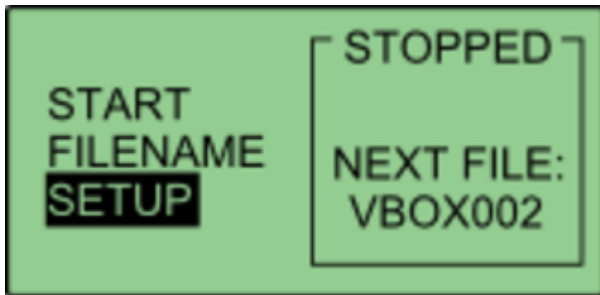

2. Then select '**ADAS**'.

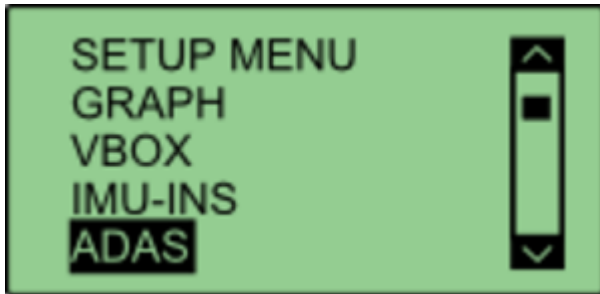

3. Select '**MULTI STATIC POINTS**'.



4. Once selected, a 'tick' icon will be displayed next to the '**MULTI STATIC POINTS**' menu and it would have expanded to include:

- Survey Mode
- Field of View
- Smoothing

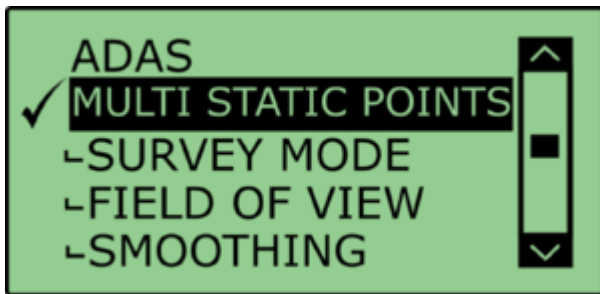

The VBOX is now set to '**MULTI STATIC POINTS**' mode.





---

## Setting the 'Field of View'

The Field of view is a circular arc that defines when a feature should be referenced, represented as the orange area in the diagram below. If a static point lies outside of this area, it will be ignored until it enters the field of view.

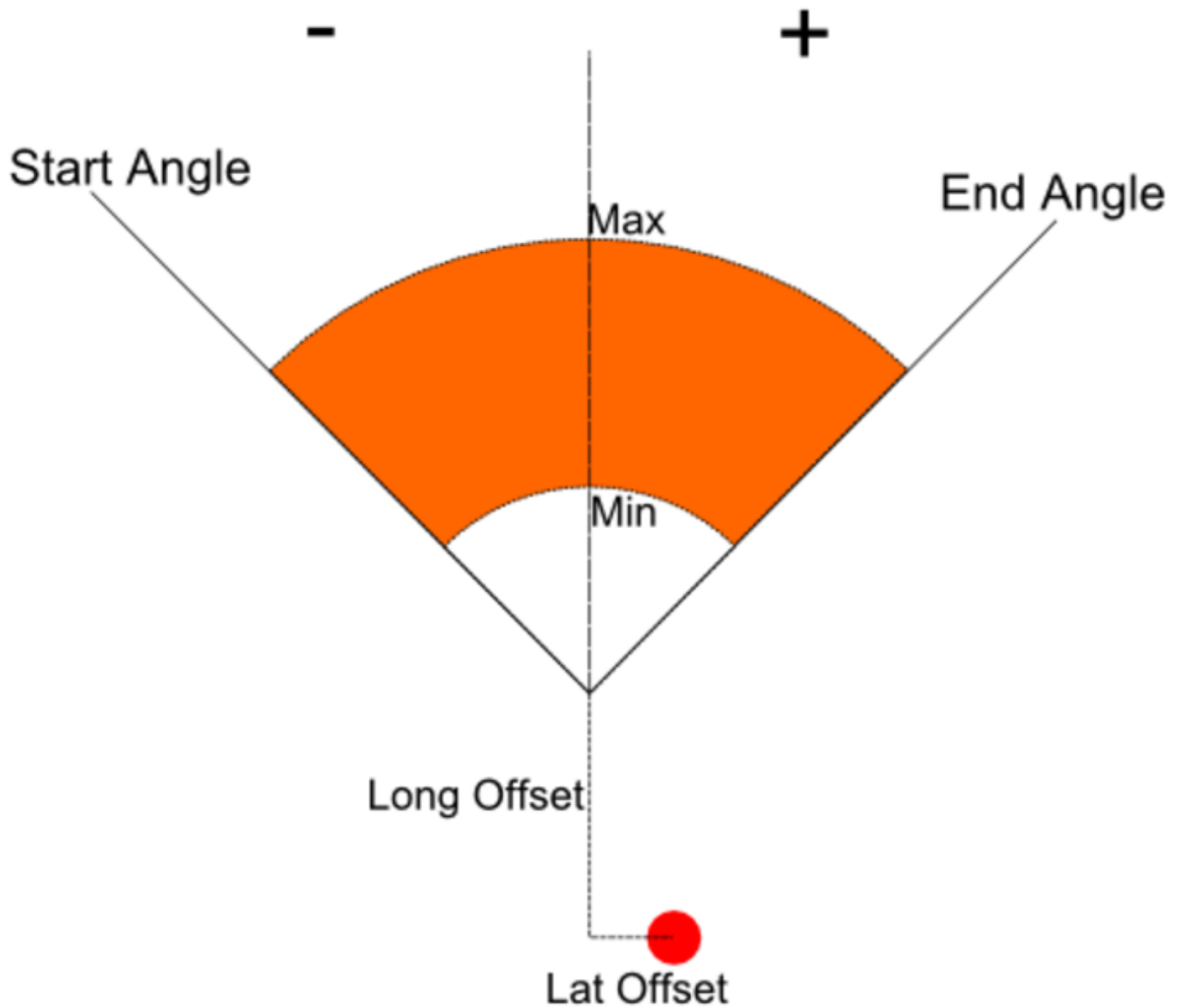

## Defining the Field of View using VBOX Manager

1. Under the '**MULTI STATIC POINT**' menu, enter the '**FIELD OF VIEW**' menu.

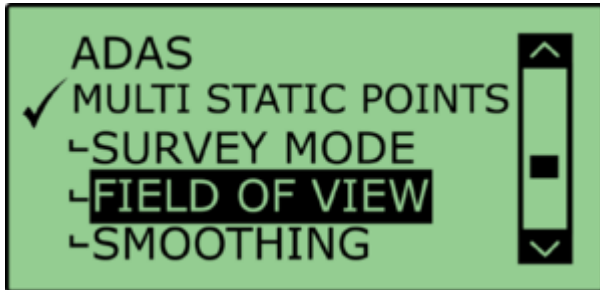

2. Enter the '**OFFSET**' menu. This menu allows the user to translate the antenna position to another position on the vehicle (usually the sensor position).

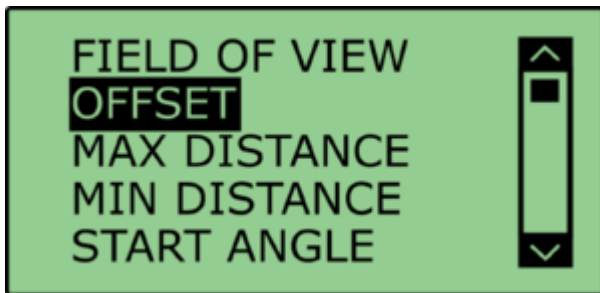

3. The offset point will be the start of the field of view. This is done by entering either a '**LNG RANGE**' and '**LAT RANGE**' offset, with forwards and right directions being positive.



4. Enter the '**MAX DISTANCE**' menu. In this menu it is possible to define the distance, in metres, from the offset point that the field of view will end.



5. Once the distance has been set, press the '**APPLY**' button.

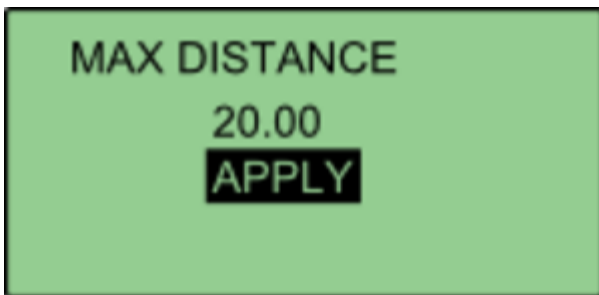

6. Enter the '**MIN DISTANCE**' menu. Similar to the 'MAX DISTANCE' menu, this allows the user to define the distance from the offset point that the field of view will start.



7. Once the distance has been set, press the '**APPLY**' button.

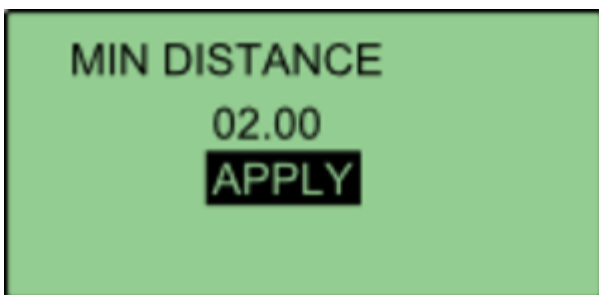

8. Enter the '**START ANGLE**' menu. This allows the user to define the angle from the centreline at which the field of view will start. Anything to the left of the centre line will be negative, anything to the right hand side will be positive.



9. Once the angle has been set, press the '**APPLY**' button.



10. Enter the '**END ANGLE**' menu. This allows the user to define the angle from the centreline at which the field of view will end. Anything to the left of the centre line will be negative, anything to the right hand side will be positive.

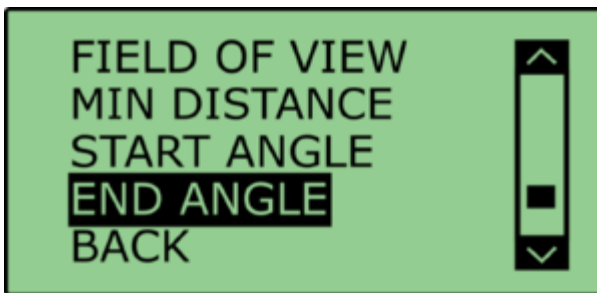

11. Once the angle has been set, press the '**APPLY**' button.



---

## Setting Static Points

1. Under the '**MULTI STATIC POINTS**' menu, enter the '**SURVEY MODE**' menu.

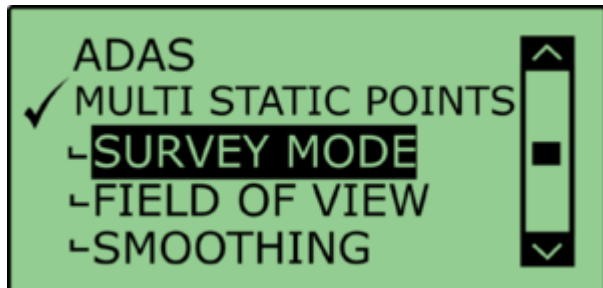

2. Select the '**EDIT POINTS**' menu.

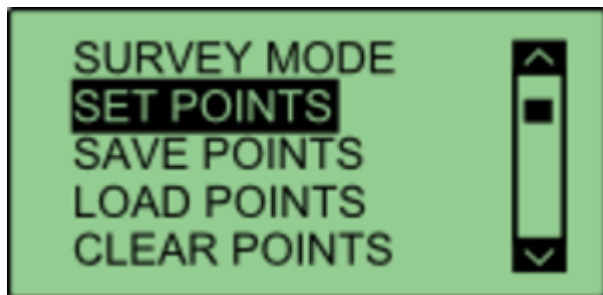

3. To define the first point of a feature, move the antenna to the required position and press '**POINT 1**'.  
If successfully saved, VBOX Manager will display the 'OK' message.

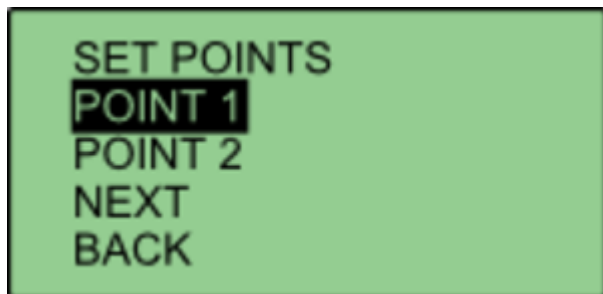

To define the second point of a feature, move the antenna to the required position and press '**POINT 2**'.  
If successfully saved, VBOX Manager will display the 'OK' message.

*Note: This step can be skipped if the user requires the feature to only have one point.*



4. Once one/both points have been surveyed, select '**NEXT**'.

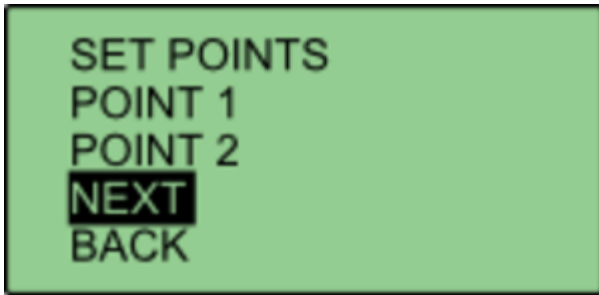

5. VBOX Manager will then display a 'FEATURE 1 SAVED' message.



Repeat this process as required.

The saved features can be cleared at any time using the '**CLEAR POINTS**' option under the '**SURVEY MODE**' menu.

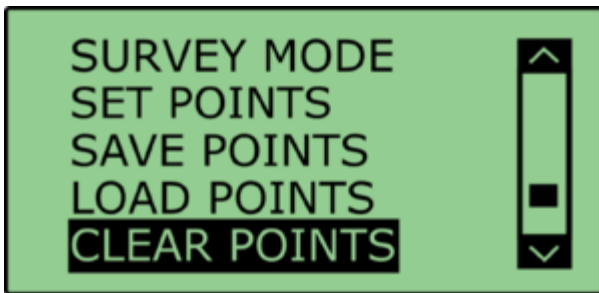

---

## Saving Static Points

Once the static points have been surveyed, it is possible to save all surveyed static points.

1. Under the '**SURVEY MODE**' menu, select '**SAVE POINTS**'. This allows the user to either create a new save file, or replace an existing file.

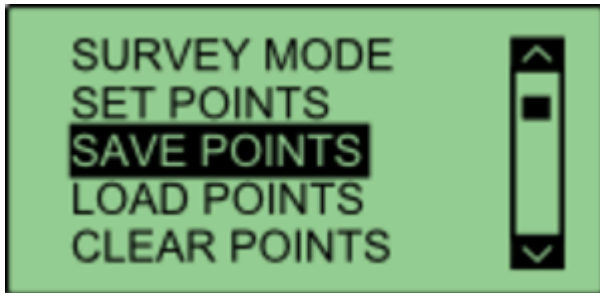

2. To replace a file, simply select the file name you wish to replace, in this case, the file called 'EXAMPLE'.



3. To create a new file, select '{CREATE NEW}'. This will bring up an alpha numeric scroll wheel where the user can enter the desired file name.

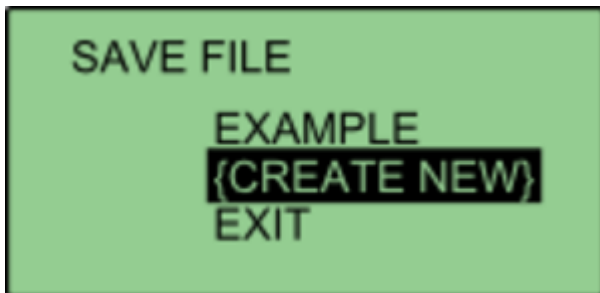

4. Once saved, VBOX Manager will display a '**SAVE SUCCESSFUL**' message.



---

## Loading Static Points

If a previously saved file is present on the compact flash card, it is possible to load those points.

1. Under the '**SURVEY MODE**' menu, select '**LOAD POINTS**'. This will bring up a list of all previously saved files that are present on the compact flash card.

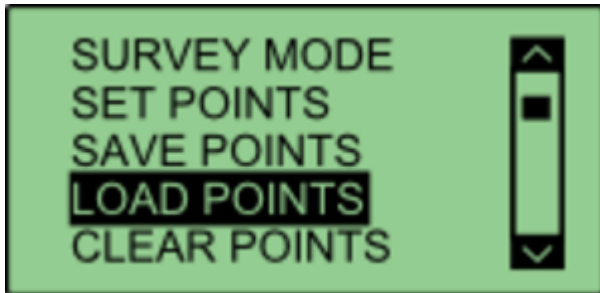

2. Selecting a file name will load that file into the VBOX.

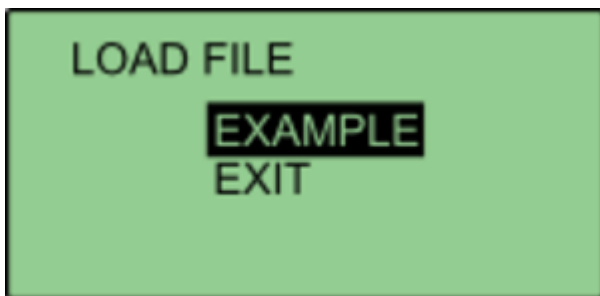

## Smoothing

If the box is set into twin antenna mode, the smoothing menu will not be present as the calculations will run off of the True heading provided by the twin antenna lock.

It is recommended that if user intends to set multiple points on the car, they enable the dual antenna.

There are two configurable variables linked to heading smoothing; 'Smoothing Distance' and 'Speed Threshold'. Due to the nature of the vehicle separation measurement and calculation process many channels are derived using the heading of the vehicle which can inherently be noisy. To overcome this heading can be smoothed with a dynamic smoothing routine.





## Smoothing Distance

The vehicle heading is normally calculated between the current and previous sample. Even with the stability of RTK position GPS position can vary by a few millimetres with respect to the original. When the travelled distance between subsequent samples is short (low speeds) this leads to a potential larger potential error in the calculated heading.

This smoothing routine allows the user to force a 'Smoothing Distance' over which heading is calculated. This is therefore dynamic, resulting in a variable number of samples used to determine the smoothing level on the heading; the lower the speed the more samples that are used. With 100 Hz logging and a smoothing distance of 1 m at 72 km/h, the heading is calculated over the previous 5 samples, whilst at 15 km/h the heading would be calculated over the previous 26 samples.

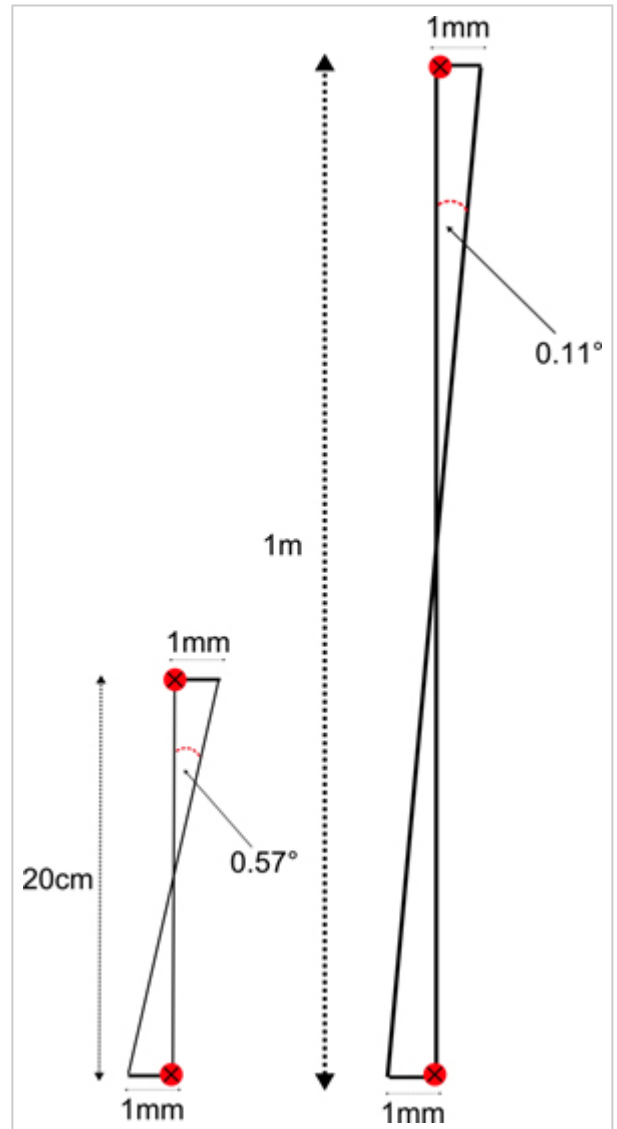

Vehicle travelling at 20 km/h in a straight path (not to scale)

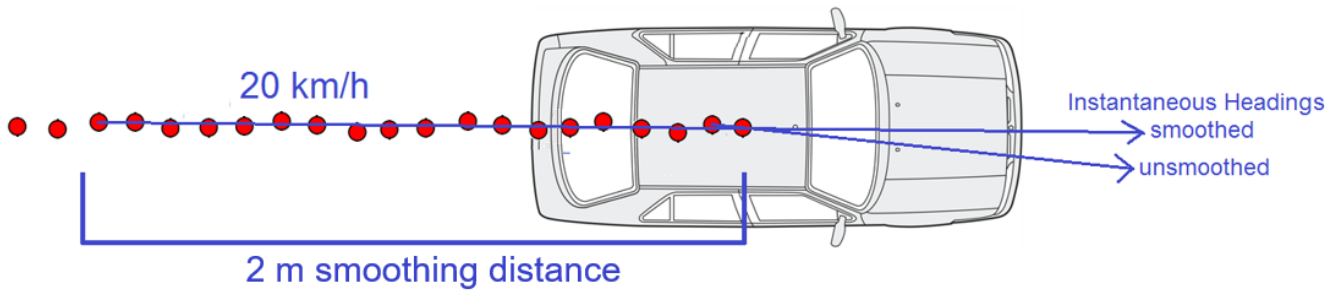

Above: Shows the improvement on vehicle heading from using smoothing distance

### Setting A Smoothing Distance

1. Select '**SMOOTHING**' from the '**MULTI STATIC POINTS**' menu.
2. Select '**SMOOTHING DIST**' and enter the smoothing option for the Subject Vehicle, from the options between 0.00 m and 2.00 m.

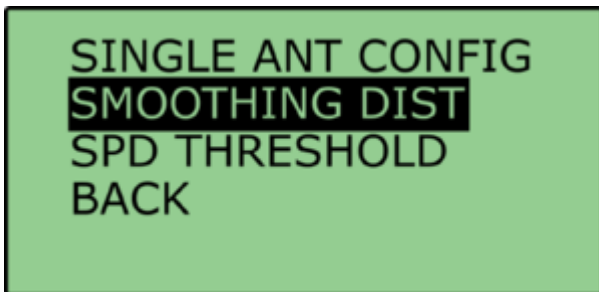

3. For typical Vehicle Separation applications we recommend a smoothing distance of 1 m.



## Speed Threshold

Due to the nature of how heading is calculated, even when Smoothing is applied at very low speeds and when the vehicle is stationary the heading channel can become very noisy and unusable, this in turn results in many of the Vehicle Separation channels becoming noisy at low speed and unusable when stationary. This is solved by fixing the heading below a configurable Speed Threshold.

1. To set the speed threshold repeat step 1 above, then select '**SPD THRESHOLD**' and enter the speed threshold option for the Subject Vehicle.

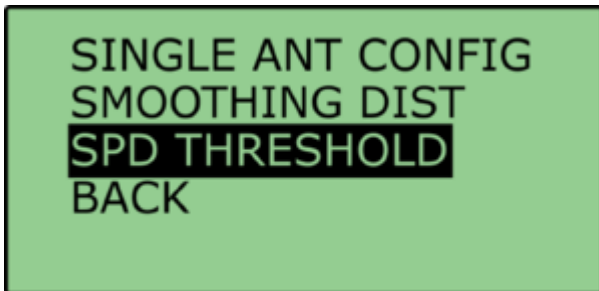

2. We recommend a Speed Threshold of 5 km/h.



## ADAS CAN Input Configurations

The following diagrams all assume the use of a static base station. If a moving base station is used, different radio setups will be needed. Please refer to the individual test setup pages for details on moving base radio connections.

The items greyed out are not essential but many customers may find them beneficial.

### Single CAN bus connection

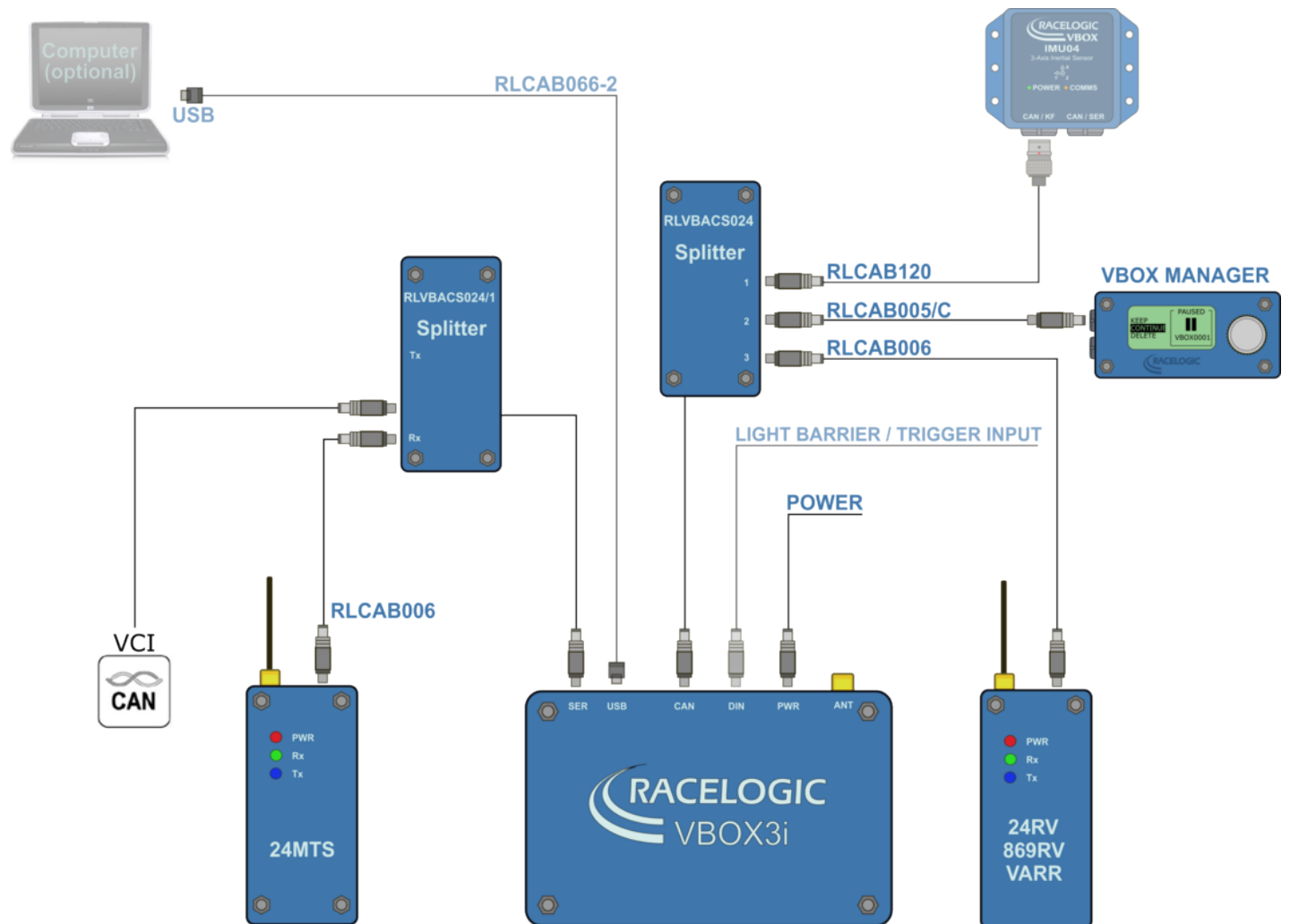

# With Video VBOX

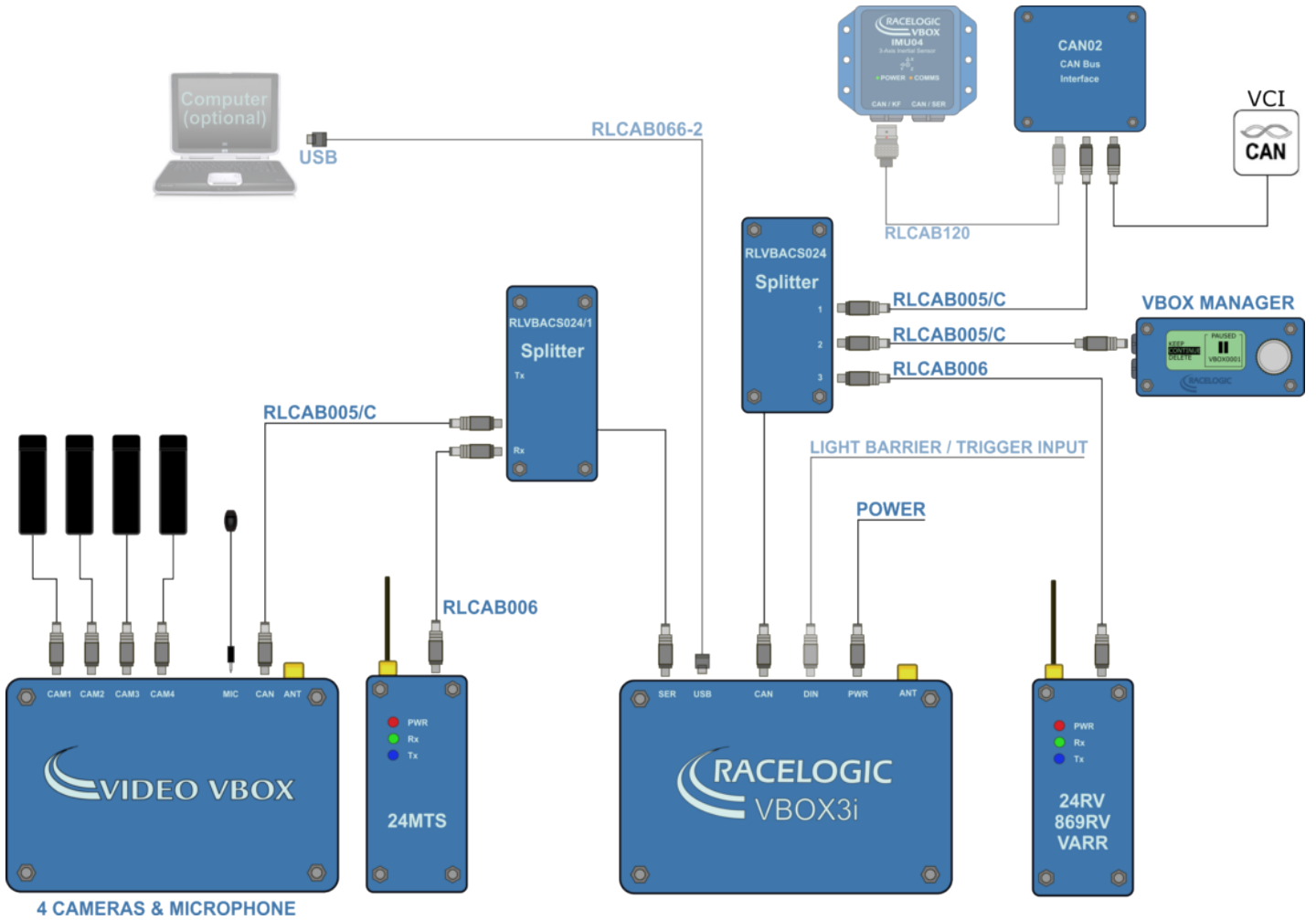

## Dual CAN bus connection

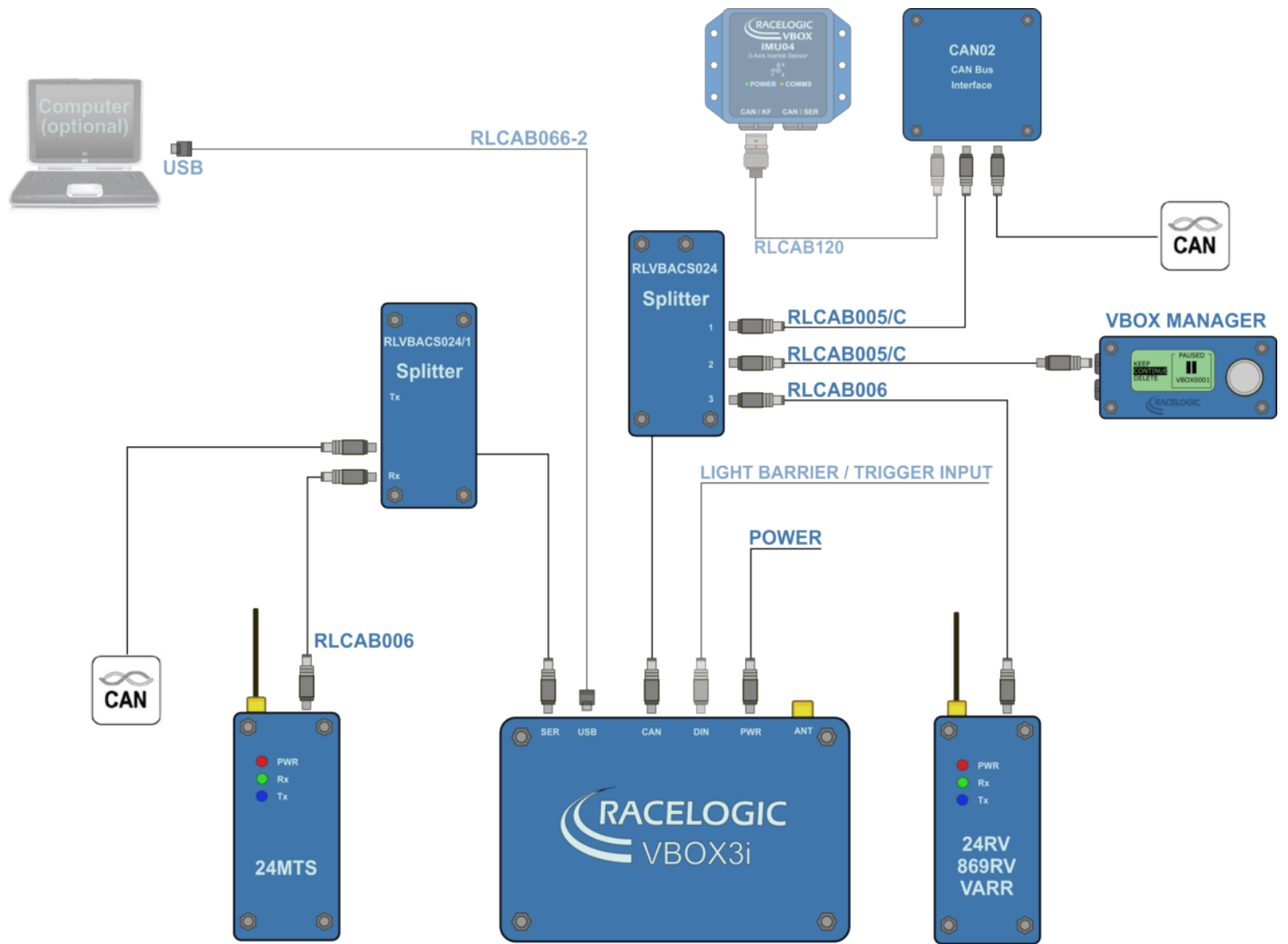

# With Video VBOX

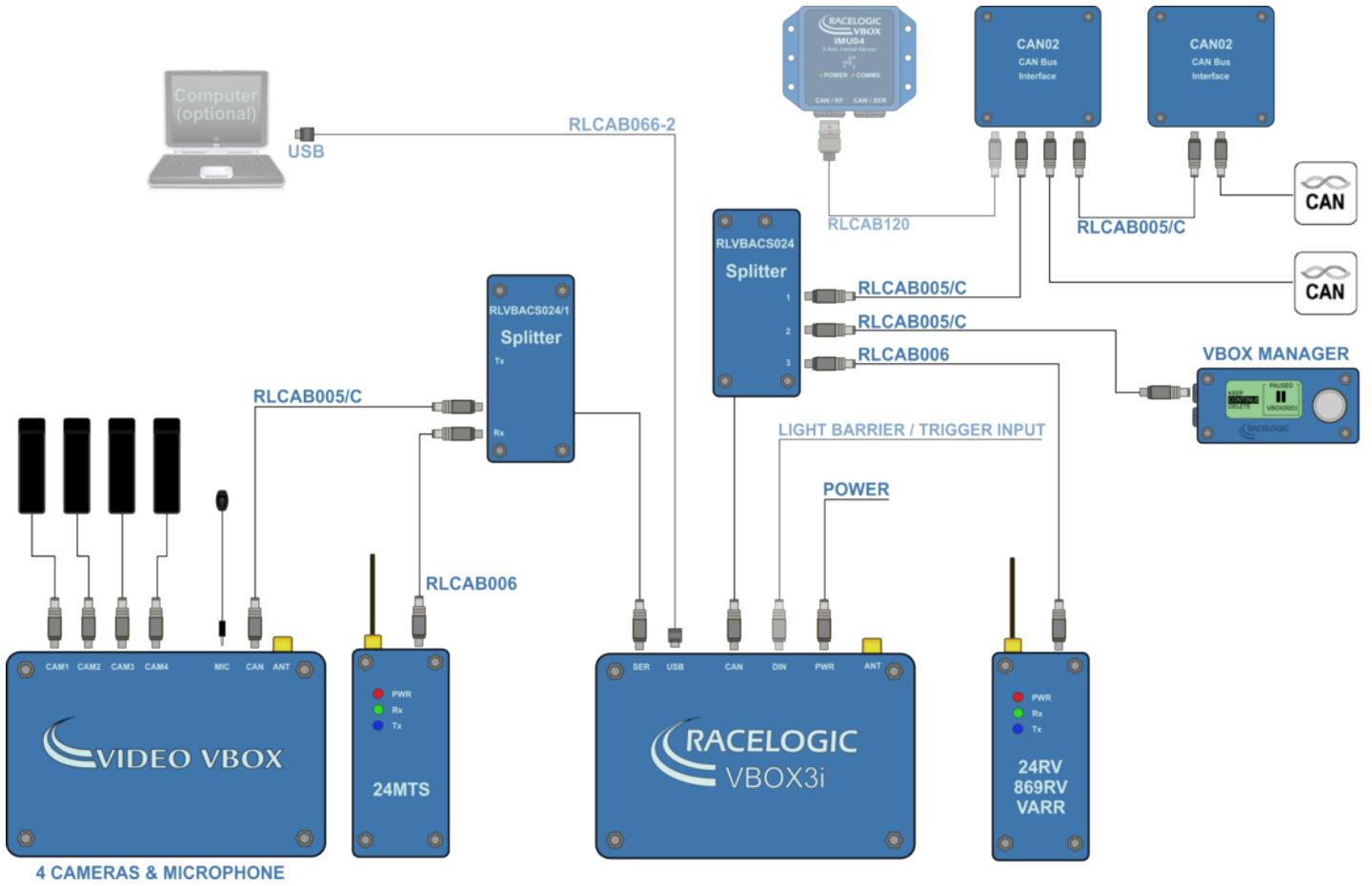

## ADAS CAN outputs

It is possible to output the VBOX ADAS channels to a 3rd party data logger on the VBOX 'VCi' CAN port, which is as default assigned to the 'SER' connector.

If the 3rd party logger has a 9 way D-sub connector then a RLCAB019L cable should provide the required interface.

**Note that when this CAN port is outputting CAN that the VBOX cannot log CAN signals via this port.**

All standard and ADAS parameters are output in a set format, which is outlined in the 'CAN Bus data format' section below.

It is possible to change the ID of each output CAN message, via the CAN page of VBOXTOOLS - VBOX setup.

---

## CAN Signal Latency

The VBOX in vehicle separation ADAS mode will have the following CAN output timings.

47.5 – 49.5 ms delay from 'ground truth' to leading edge of the associated CAN message when IMU integration and fixed CAN delay is disabled.

This becomes 60 ms delay when IMU integration or Fixed CAN delay is enabled.

VBOX output CAN message is 5 ms in length at 500 kbit/s.

---

## Standard ADAS CAN Data

Listed below are the standard CAN messages that are transmitted from the VB3iSL-RTK in any mode of operation. The ID's of the CAN messages can be configured through VBOX Tools software if required.

All channels **shown in blue** are channels available when Twin antenna mode is enabled.

All CAN id's **highlighted in yellow** are not subject to an additional 3 sample delay that is present when any Vehicle separation ADAS mode is enabled.

[Click here to download ADAS DBC files.](#)

**Data format:** Motorola





ID**	Data Bytes							
	1	2	3	4	5	6	7	8
0x301	(1) Sats	(2) Time_since_midnight.UTC		(3) Position_Latitude				
0x302	(4) Position_Longitude			(5) Speed_Knots		(6) Heading		
0x303	(7) Altitude			(8) Vertical_velocity_ms		Unused	(9) Status	(10) Status
0x304	(11) Trigger_Distance				(12) Longitudinal_Accel_g		(13) Lateral_Accel_g	
0x305	(14) Distance				(15) Trigger_Time		(16) Trigger_Speed_Knots	
0x306	(17) Speed_Quality		(18) True_Heading		(19) Slip_Angle		(20) Pitch_Angle	
0x307	(21) Lateral_Velocity_kmh		(22) Yaw_Rate		(23) Roll_Angle		(24) Longitudinal_Velocity_kmh	
0x308	(25) Position_latitude_48bit						(26) Kalman_Filter_Status	
0x309	(27) Position_longitude_48bit						(28) Robot_Nav_Speed_Knots	
0x313	(29) Slip_Angle_Front_Left		(30) Slip_Angle_Front_Right		(31) Slip_Angle_Rear_Left		(32) Slip_Angle_Rear_Right	
0x314	(33) Slip_Angle_COG		(34) Robot_Nav_Satellites	(35) Robot_Nav_Time_Since_Midnight			(36) Robot_Nav_Heading	
0x322	(37) Trigger event UTC time – milliseconds (part1)				(38) Trigger event UTC time – nanoseconds (part 2)			
0x323	(39) Head_IMU		(40) Roll_IMU		(41) Pitch_IMU		Unused	
0x324	Unused				(42) FW Version			

\*Update rate depends on GPS update rate. 10 ms Update rate shown corresponds to 100 Hz GPS setting.

\*\*Default Identifiers. The identifier values can be changed using the configuration software.

1. If Satellites in view < 3 then only Identifier 0x301 transmitted and bytes 2 to 8 are set to 0x00.



2. Time since midnight. This is a count of 10 ms intervals since midnight UTC. (5383690 = 53836.90 seconds since midnight or 14 hours, 57 minutes and 16.90 seconds).
3. Position, Latitude in minutes \* 100,000 (311924579 = 51 Degrees, 59.24579 Minutes North). This is a true 32 bit signed integer, North being positive.
4. Position, Longitude in minutes \* 100,000 (11882246 = 1 Degrees, 58.82246 Minutes West). This is a true 32 bit signed integer, West being positive.
5. Velocity, 0.01 knots per bit.
6. Heading, 0.01° per bit.
7. Altitude above the WGS 84 ellipsoid, 0.01 meters per bit, signed.
8. Vertical Velocity, 0.01 m/s per bit, signed.
9. Status. 8 bit unsigned char. Bit 0=VBOX Lite, Bit 1=Open or Closed CAN Bus (1=open), 2=VBOX3, Bit 3 = Logging Status.
10. Status is an 8 bit unsigned char. Bit 0 is always set, Bit 2=brake test started, Bit 3 = Brake trigger active, Bit 4 = DGPS active, Bit 5 = Dual Lock.
11. Distance, 0.000078125 meters per bit, unsigned. Corrected to trigger point..
12. Longitudinal Acceleration, 0.01 g per bit, signed.
13. Lateral Acceleration, 0.01 g per bit, signed.
14. Distance traveled since VBOX reset, 0.000078125 meters per bit, unsigned.
15. Time from last brake trigger event. 0.01 seconds per bit.
16. Velocity at brake trigger point 0.01 knots per bit.
17. Velocity Quality, 0.01 km/h per bit.
18. True Heading of vehicle, 16 bit signed integer, 0.01° per bit.
19. Slip Angle, 16 bit signed integer 0.01° per bit.
20. Pitch Angle, 16 bit signed integer 0.01° per bit.
21. Lateral Velocity, 16 bit signed integer 0.01 knots per bit.
22. Yaw Rate, 16 bit signed integer 0.01°/s per bit.
23. Roll Angle, 16 bit signed integer 0.01° per bit.
24. Longitudinal Velocity, 16 bit signed integer 0.01 knots per bit.
25. Position, Latitude 48bit signed integer, Latitude \* 10,000,000 (minutes). North being positive.
26. Kalman filter status, 12 bit unsigned integer. See [VBOX 3i Kalman Filter Status](#) for details.
27. Position, Longitude 48 bit signed integer, Longitude \* 10,000,000 (minutes). East being positive.
28. Velocity, 0.01 knots per bit (not delayed when ADAS enabled).
29. Slip Angle Front Left, 16 bit signed integer 0.01° per bit.
30. Slip Angle Front Right, 16 bit signed integer 0.01° per bit.
31. Slip Angle Rear Left, 16 bit signed integer 0.01° per bit.
32. Slip Angle Rear Right, 16 bit signed integer 0.01° per bit.
33. Slip Angle C of G, 16 bit signed integer 0.01° per bit.
34. Robot navigation satellites.
35. Time since midnight. This is a count of 10 ms intervals since midnight UTC. (5383690 = 53836.90 seconds since midnight or 14 hours, 57 minutes and 16.90 seconds) (not delayed when ADAS enabled).



36. True Heading2 16 bit signed integer 0.01° per bit, (not delayed when ADAS enabled).
37. Trigger event UTC time - milliseconds since midnight UTC (part 1 of 2 part message).
38. Trigger event UTC time - nanoseconds since midnight UTC (part 2 of 2 part message).
39. Heading derived from the Kalman Filter.
40. Roll Angle derived from Kalman Filter.
41. Pitch Angle derived from Kalman Filter.
42. VBOX FW version, 32 bit unsigned.
43. \*can be split into Major (8bit), Minor (8 bit) and build number (16 bit).

## Vehicle Separation - Target 1 CAN Data

Below is the tabular list of additional ADAS CAN messages that are present at the Subject VBOX vci output CAN port, when Single target/ Multiple Target veh sep or Static point mode is used. The ID's of the CAN messages can be configured through VBOX Tools software if required.

[Click here to download the ADAS Vehicle Separation DBC file.](#)

Data format: Motorola

ID**	Data Bytes							
	1	2	3	4	5	6	7	8
0x30A	(1) Range_tg1				(2) RelSpd_tg1_km/h			
0x30B	(3) LngRsv_tg1				(4) LatRsv_tg1			
0x30C	(5) LngSsv_tg1_km/h				(6) LatSsv_tg1_km/h			
0x30D	(7) Angle_tg1				(8) Status_tg1	(9) LkTime_tg1		
0x30E	(10) LatRtg_tg1				(11) LngRtg_tg1			
0x30F	(12) T2Csv_tg1				(13) Status_sv	Unused	(14) Yawdif_tg1	
0x310	(15) Spd_tg1_ms				(16) T2C2sv_tg1			
0x311	(17) LatRref_tg1				(18) Accel_tg1			
0x312	(19) SepTim_tg1				(20) T2Ctg_tg1			
0x315	(21) Latdif_tg1				(22) Lngdiff_tg1			



ID**	Data Bytes							
	1	2	3	4	5	6	7	8
<b>0x316</b>	(23) YawRat_tg1				(24) PntSv_tg1	(25)PntTg1_s	Unused	
<b>0x325</b>	(26) LngRref_tg1***				Unused			

\*Update rate depends on GPS update rate. 10 ms Update rate shown corresponds to 100 Hz GPS setting.

\*\*Default Identifiers. The identifier values can be changed using the configuration software.

\*\*\*New channels added for 2.4 firmware release

1. Vehicle Separation (m), 32 bit IEEE Float.
2. Relative Speed (km/h), 32 bit IEEE Float.
3. Longitudinal Range; wrt subject heading (meters), 32 bit IEEE Float.
4. Lateral Range; wrt subject heading (meters), 32 bit IEEE Float.
5. Longitudinal Speed; wrt subject heading (meters), 32 bit IEEE Float.
6. Lateral Speed; wrt subject heading (meters), 32 bit IEEE Float.
7. Separation Angle (°), 32 bit IEEE Float.
8. Target RTK status 8 bit unsigned integer, 0=No solution,1= Stand alone, 2= Code differential, 3=RTK Float, 4=RTK Fixed.
9. Link Time 24 bit unsigned integer, count of 10 ms counts since midnight.
10. Lateral Range; wrt Target heading (m), 32 bit IEEE Float.
11. Longitudinal Range; wrt Target heading (m), 32 bit IEEE Float.
12. Time to collision; wrt subject heading (seconds), 32 bit IEEE Float.
13. Subject Status, 8 bit unsigned integer, 0=No solution,1= Stand alone, 2= Code differential, 3=RTK Float, 4=RTK Fixed.
14. YAW diff, difference between subject and target1 vehicle headings, 16 bit signed integer \*100.
15. Target Vehicle Speed (km/h), 32 bit IEEE Float.
16. Time to Collision 2; (seconds), 32 bit IEEE Float.
17. Lateral Diff (m), 32 bit IEEE Float.
18. Target vehicle Acceleration (g), 32 bit IEEE Float.
19. Separation Time (seconds), 32 bit IEEE Float.
20. Time to Collision Target; wrt target heading (seconds), 32 bit IEEE Float.
21. Latdif\_tg1 difference in minutes between Subject Latitude and Target 1Latitude, 32 bit IEEE Float.
22. Lngdif\_tg1 difference in minutes between Subject Longitude and Target 1 Longitude, 32 bit IEEE Float.
23. YawRat\_tg1 Yaw rate from target vehicle, only if fitted (deg/s), 32bBit IEEE Float.



24. Current subject vehicle contact point to target vehicle 1 – 8 bit unsigned integer.
25. Current target vehicle 1 contact point – 8 bit unsigned integer.
26. Longitudinal Diff (m), 32 bit IEEE Float.

## Vehicle Separation - Target 2 CAN Data

Below is the tabular list of additional ADAS CAN messages that are present at the Subject VBOX vci output CAN port, when 'multiple target' mode is used. The ID's of the CAN messages can be configured through VBOX Tools software if required.

[Click here to download the ADAS Vehicle Separation DBC file.](#)

**Data format:** Motorola

ID**	Data Bytes							
	1	2	3	4	5	6	7	8
<b>0x317</b>	(1) Range_tg2				(2) RelSpd_tg2_km/h			
<b>0x318</b>	(3) LngRsv_tg2				(4) LatRsv_tg2_m			
<b>0x319</b>	(5) LngSsv_tg2_km/h				(6) LatSsv_tg2_km/h			
<b>0x31A</b>	(7) Angle_tg2				(8) Status_tg2	(9) LkTime_tg2		
<b>0x31B</b>	(10) LatRtg_tg2				(11) LngRtg_tg2			
<b>0x31C</b>	(12) T2Csv_tg2				(13) Status_sv	Unused	(14) Yawdif_tg2	
<b>0x31D</b>	(15) Spd_tg2_km/h				(16) T2C2sv_tg2			
<b>0x31E</b>	(17) LatRref_tg2				(18) Accel_tg2			
<b>0x31F</b>	(19) SepTim_tg2				(20) T2Ctg_tg2			
<b>0x320</b>	(21) Latdif_tg2				(22) Lngdiff_tg2			
<b>0x321</b>	(23) YawRat_tg2				(24) PntSv_tg2	(25)PntTg2_sv	Unused	
<b>0x326</b>	(26) LngRref_tg2***				Unused			



\*Update rate depends on GPS update rate. 10 ms Update rate shown corresponds to 100 Hz GPS setting.

\*\*Default Identifiers. The identifier values can be changed using the configuration software.

\*\*\*New channels added for 2.4 firmware release

1. Vehicle Separation (m), 32 bit IEEE Float.
2. Relative Speed (km/h), 32 bit IEEE Float.
3. Longitudinal Range; wrt subject heading (m), 32 bit IEEE Float.
4. Lateral Range; wrt subject heading (m), 32 bit IEEE Float.
5. Longitudinal Speed; wrt subject heading (m), 32 bit IEEE Float.
6. Lateral Speed; wrt subject heading (m), 32 bit IEEE Float.
7. Separation Angle ( $^{\circ}$ ), 32 bit IEEE Float.
8. Target RTK status 8 bit unsigned integer, 0=No solution, 1= Stand alone, 2= Code differential, 3=RTK Float, 4=RTK Fixed.
9. Link Time 24 bit unsigned integer, count of 10 ms counts since midnight.
10. Lateral Range; wrt Target heading (m), 32 bit IEEE Float.
11. Longitudinal Range; wrt Target heading (m), 32 bit IEEE Float.
12. Time to collision; wrt subject heading (seconds), 32 bit IEEE Float.
13. Subject Status, 8 bit unsigned integer, 0=No solution, 1= Stand alone, 2= Code differential, 3=RTK Float, 4=RTK Fixed.
14. YAW diff, difference between subject and target2 vehicle headings, 16 bit signed integer \*100.
15. Target Vehicle Speed (km/h), 32 bit IEEE Float.
16. Time to Collision 2; (seconds), 32 bit IEEE Float.
17. Lateral Diff (m), 32 bit IEEE Float.
18. Target vehicle Acceleration (g), 32 bit IEEE Float.
19. Separation Time (seconds), 32 bit IEEE Float.
20. Time to Collision Target; wrt target heading (seconds), 32 bit IEEE Float.
21. Latdif\_tg2 difference in minutes between Subject Latitude and Target 2 Latitude, 32 bit IEEE Float.
22. Lngdif\_tg2 difference in minutes between Subject Longitude and Target 2 Longitude, 32 bit IEEE Float.
23. YawRat\_tg2 Yaw rate from Target 2 vehicle, only if fitted (deg/s), 32 bit IEEE Float.
24. Current subject vehicle contact point to target vehicle 2 – 8 bit unsigned integer.
25. Current target vehicle 2 contact point – 8 bit unsigned integer.
26. Longitudinal Diff (m), 32 bit IEEE Float.



---

## Lane Departure CAN Data

The standard VBOX CAN output is extended with additional identifiers containing vehicle separation data when the VBOX is set to 'Lane Departure' mode. The ID's of the CAN messages can be configured through VBOX Tools software if required.

[Click here to download the ADAS Lane Departure DBC file.](#)

**Data format: Motorola**

ID**	Data Bytes							
	1	2	3	4	5	6	7	8
<b>0x30A</b>	(1) Range_FL				(2) Range_FR			
<b>0x30B</b>	(3) LatSpd_FL_km/h				(4) Status			
<b>0x30C</b>	(5) TTC_FL				(6) LatSpd_FR_km/h			
<b>0x30D</b>	(7) TTC_FR				(8) Angle			
<b>0x30E</b>	(9) Range_RL				(10) Range_RR			
<b>0x30F</b>	(11) LatSpd_RL_km/h				(12) LatSpd_RR_km/h			
<b>0x310</b>	(13) TTC_RL				(14) TTC_RR			

\*Default Identifiers. The identifier values can be changed using the configuration software.

1. Lateral Distance to Line from vehicle front left point (meters), 32 bit IEEE Float.
2. Lateral Distance to Line from vehicle front right point (meters), 32 bit IEEE Float.
3. Lateral speed toward line wrt to vehicle front left point (km/h), 32 bit IEEE Float.
4. Status, 32 Bit IEEE Float, 0=No solution, 1= Stand alone, 2= Code differential, 3=RTK Float, 4=RTK Fixed.
5. Time To Line cross, wrt to vehicle front left point, (seconds), 32 bit IEEE Float.
6. Lateral speed toward line wrt to vehicle front right point (km/h), 32 bit IEEE Float.
7. Time To Line cross, wrt to vehicle front right point, (seconds), 32 bit IEEE Float.
8. Angle (°), 32 bit IEEE Float.
9. Lateral Distance to Line from vehicle rear left point (m), 32 bit IEEE Float.
10. Lateral Distance to Line from vehicle rear right point (m), 32 bit IEEE Float.
11. Lateral speed toward line wrt to vehicle rear left point (km/h), 32 bit IEEE Float.
12. Lateral speed toward line wrt to vehicle rear right point (km/h), 32 bit IEEE Float.
13. Time To Line cross, wrt to vehicle rear left point, (seconds), 32 bit IEEE Float.



14. Time To Line cross, wrt to vehicle rear right point, (seconds), 32 bit IEEE Float.

## Multi Static Point CAN Data

The standard VBOX CAN output is extended with additional identifiers containing vehicle separation data when the VBOX is set to “Multiple Static Points” mode. The ID’s of the CAN messages can be configured through VBOX Tools software if required.

[Click here to download the ADAS Multi Static Point DBC file.](#)

**Data format:** Motorola

ID**	Data Bytes							
	1	2	3	4	5	6	7	8
<b>0x30A</b>	(1) ID1		(2) Range1 (m)		(3) Lat_Range1 (m)		(4) Lng_Range1 (m)	
<b>0x30B</b>	(5) TTC1 (sec)		(6) Angle1 (degrees)		Unused		Unused	
<b>0x30C</b>	(7) ID2		(8) Range2 (m)		(9) Lat_Range2 (m)		(10) Lng_Range2 (m)	
<b>0x30D</b>	(11) TTC2 (sec)		(12) Angle2 (degrees)		Unused		Unused	
<b>0x30E</b>	(13) ID3		(14) Range3 (m)		(15) Lat_Range3 (m)		(16) Lng_Range3 (m)	
<b>0x30F</b>	(17) TTC3 (sec)		(18) Angle3 (degrees)		Unused		Unused	
<b>0x310</b>	(19) ID4		(20) Range4 (m)		(21) Lat_Range4 (m)		(22) Lng_Range4 (m)	
<b>0x311</b>	(23) TTC4 (sec)		(24) Angle4 (degrees)		Unused		Unused	
<b>0x312</b>	(25) ID5		(26) Range5 (m)		(27) Lat_Range5 (m)		(28) Lng_Range5 (m)	
<b>0x315</b>	(29) TTC5 (sec)		(30) Angle5 (degrees)		Unused		Unused	

\*Default Identifiers. The identifier values can be changed using the configuration software.

1. Point ID of the feature, 16 bit unsigned integer.
2. Distance to feature from the origin of the field of vision (m), 16 bit unsigned integer.
3. Lateral Distance to feature from the origin of the field of vision (m), 16 bit signed integer.
4. Longitudinal Distance to feature from the origin of the field of vision (m), 16 bit unsigned integer.
5. Time to Collision wrt to the feature point (seconds), 16 bit unsigned integer.
6. Angle of the feature wrt to the vehicle heading (°), 16 bit unsigned integer.
7. Point ID of the feature, 16 bit unsigned integer.





8. Distance to feature from the origin of the field of vision (m), 16 bit unsigned integer.
9. Lateral Distance to feature from the origin of the field of vision (m), 16 bit signed integer.
10. Longitudinal Distance to feature from the origin of the field of vision (m), 16 bit unsigned integer.
11. Time to Collision wrt to the feature point (seconds), 16 bit unsigned integer.
12. Angle of the feature wrt to the vehicle heading ( $^{\circ}$ ), 16 bit unsigned integer.
13. Point ID of the feature, 16 bit unsigned integer.
14. Distance to feature from the origin of the field of vision (m), 16 bit unsigned integer.
15. Lateral Distance to feature from the origin of the field of vision (meters), 16 bit signed integer.
16. Longitudinal Distance to feature from the origin of the field of vision (meters), 16 bit unsigned integer.
17. Time to Collision wrt to the feature point (seconds), 16 bit unsigned integer.
18. Angle of the feature wrt to the vehicle heading ( $^{\circ}$ ), 16 bit unsigned integer.
19. Point ID of the feature, 16 bit unsigned integer.
20. Distance to feature from the origin of the field of vision (m), 16 bit unsigned integer.
21. Lateral Distance to feature from the origin of the field of vision (m), 16 bit signed integer.
22. Longitudinal Distance to feature from the origin of the field of vision (m), 16 bit unsigned integer.
23. Time to Collision wrt to the feature point (seconds), 16 bit unsigned integer.
24. Angle of the feature wrt to the vehicle heading ( $^{\circ}$ ), 16 bit unsigned integer.
25. Point ID of the feature, 16 bit unsigned integer.
26. Distance to feature from the origin of the field of vision (m), 16 bit unsigned integer.
27. Lateral Distance to feature from the origin of the field of vision (m), 16 bit signed integer.
28. Longitudinal Distance to feature from the origin of the field of vision (m), 16 bit unsigned integer.
29. Time to Collision wrt to the feature point (seconds), 16 bit unsigned integer.
30. Angle of the feature wrt to the vehicle heading ( $^{\circ}$ ), 16 bit unsigned integer.



## ADAS Parameter definitions

---

### Standard Measured Parameters

The following tables provide a list of channels capable of being calculated in each vehicle within an ADAS test.

For Single Vehicle Target testing Racelogic refers to each vehicle as the 'Subject Vehicle' or the 'Target Vehicle'. For example, under testing for adaptive cruise control the lead vehicle will be the Target Vehicle, whilst the following vehicle (where the adaptive cruise control is being testing) is referred to as the Subject Vehicle.

For Multiple Vehicle Target testing, channel naming now changes such to indicate channels calculated with respect to, Target Vehicle 1 and Target Vehicle 2.

As there are now three vehicles involved with this testing the number of channels increases at the Subject Vehicle, this is reflected in the table below:

The vehicle separation channels calculated at the Target vehicle are essentially exactly the same as the channels calculated at the subject vehicle, except for the channels highlighted in **yellow**.

The channels highlighted in **grey** are not used in Static Point testing. These are listed to ensure continuity of the Racelogic report generator application, which uses channel ordering as its sort function.

**Channel name definition. Where the channel name is not obvious, then it is made up of three parts.**



The first part is the parameter type i.e. **LngR** = Longitudinal Range

The second part indicates which vehicle heading is being used in the calculation of this parameter i.e. **sv** = subject vehicle



The last part indicates which vehicle is parameter is being calculated with reference to, i.e. **tg1** = Target Vehicle 1

Name		Channel Description	Units
Target 1	Target 2		
Range-tg1	Range-tg2	Direct Distance between Subject and Target vehicle	m
LngRsv-tg1	LngRsv-tg2	Longitudinal distance between the Subject and Target Vehicles measured in the direction of the Subject Vehicle heading	m
LatRsv-tg1	LatRsv-tg2	Lateral distance between the Subject and Target Vehicles measured at right angles to the Subject Vehicle heading	m
LongRref-tg1	LongRref-tg2	The longitudinal difference between the two vehicles based on the heading of the test track*	m
LatRref-tg1	LatRref-tg2	The lateral difference between the two vehicles based on the heading of the test track*	m
T2Csv-tg1	T2Csv-tg2	Time to Collision with Target Vehicle derived from LngRsv-tg1 and LngSsv-tg1 channels	s
T2C2sv-tg1	T2C2sv-tg2	Time to Collision with a decelerating Target Vehicle derived from the LngRsv-tg1, LngSsv-tg1 and Accel-tg1 channels**	s
RelSpd-tg1	RelSpd-tg2	The relative speed between the Subject and Target Vehicles	km/h
LngRtg-tg1	LngRtg-tg2	Longitudinal distance between the Subject and Target Vehicles measured in the direction of the Target Vehicle heading	m
LatRtg-tg1	LatRtg-tg2	Lateral distance between the Subject and Target Vehicles measured at right angles to the Target Vehicle heading	m
Angle-tg1	Angle-tg2	Angle to the Target Vehicle with respect to the heading of the Subject Vehicle	°
Latdif-tg1	Latdif-tg2	The difference between Subject Vehicle and Target Vehicle latitude	min
Lngdif-tg1	Lngdif-tg2	The difference between Subject Vehicle and Target Vehicle longitude	min
Spd-tg1	Spd-tg2	Target Vehicle course over ground speed	km/h
Spd-sv	N/A	Subject Vehicle course over ground speed	km/h



Name		Channel Description	Units
Target 1	Target 2		
Accel-tg1	Accel-tg2	Target Vehicle acceleration calculated from Target Vehicle speed and time	g
LngSsv-tg1	LngSsv-tg2	The speed between the Subject and Target Vehicles in the longitudinal direction, with respect to Subject vehicle heading	km/h
LatSsv-tg1	LatSsv-tg2	The speed between the Subject and Target Vehicles in the lateral direction, at right angles to the Subject vehicle heading	km/h
Status-tg1	Status-tg2	The DGPS status of the Target vehicle VBOX	N/A
Status-sv	Status-sv	The DGPS status of the Subject vehicle VBOX	N/A
LkTime-tg1	LkTime-tg2	Rolling time sent over 2.4Ghz Radio Link, used to indicate the quality of radio link between vehicles	N/A
LkTime-sv	N/A	Rolling time sent over 2.4Ghz Radio Link, used to indicate the quality of radio link between vehicles	N/A
App_Mode	App_Mode	The current operating mode of the Subject VBOX ****	N/A
SepTim-tg1	SepTim-tg2	The time it would take the Subject Vehicle to travel across the Vehicle separation distance at its current speed	s
T2Ctg-tg1	T2Ctg-tg2	Time to Collision with Target Vehicle, derived from the LngRtg-tg1 and Target vehicle long range speed.	s
Yawdif-tg1	Yawdif-tg2	This angle is the difference between subject and target vehicle headings.	°
YawRat-tg1	YawRat-tg2	YAW rate of the Target vehicle, only available when an IMU is connected to the VBOX in the target vehicle	°/s
Pntsv-tg1	Pntsv-tg1	The current Subject vehicle contact point being referenced in the Subject to target vehicle ADAS calculations	N/A
Pnttg1-sv	Pnttg2-sv	The current Target vehicle contact point being referenced in the Subject to target vehicle ADAS calculations	N/A

\*See [LatDif-tg1 calculations](#)

\*\*See section '[Time to Collision](#)'



\*\*\*\*See section '[APP Mode](#)'

### 'LngRsv-tg1', 'LatRsv-tg1'

Longitudinal and Lateral Range with respect to subject vehicle heading.

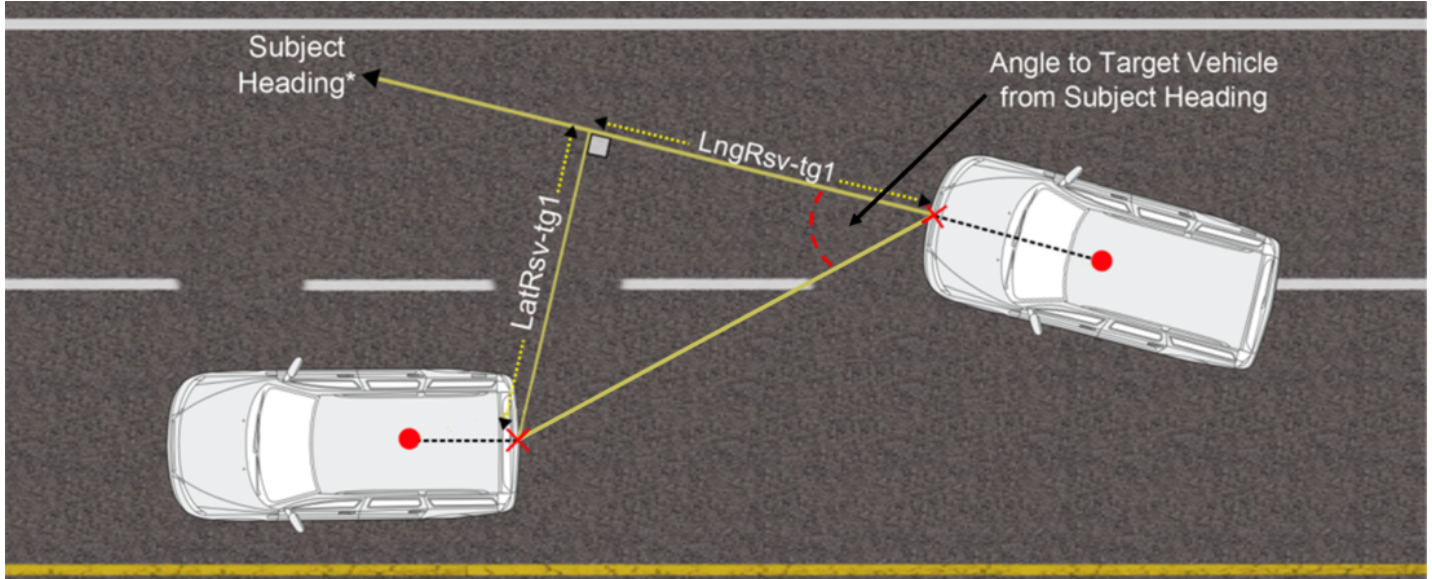

**Long Range and Lat Range parameter definition**

NOTE: The LatRsv-tg1 and LngRsv-tg1 values are calculated from offset points on each respective vehicle. Details of how to apply these offsets is provided in the quick start guide later in this manual (Section 'Pre-test configuration').

### 'LngRtg-tg1', 'LatRtg-tg1'

Longitudinal and Lateral Range with respect to target vehicle heading



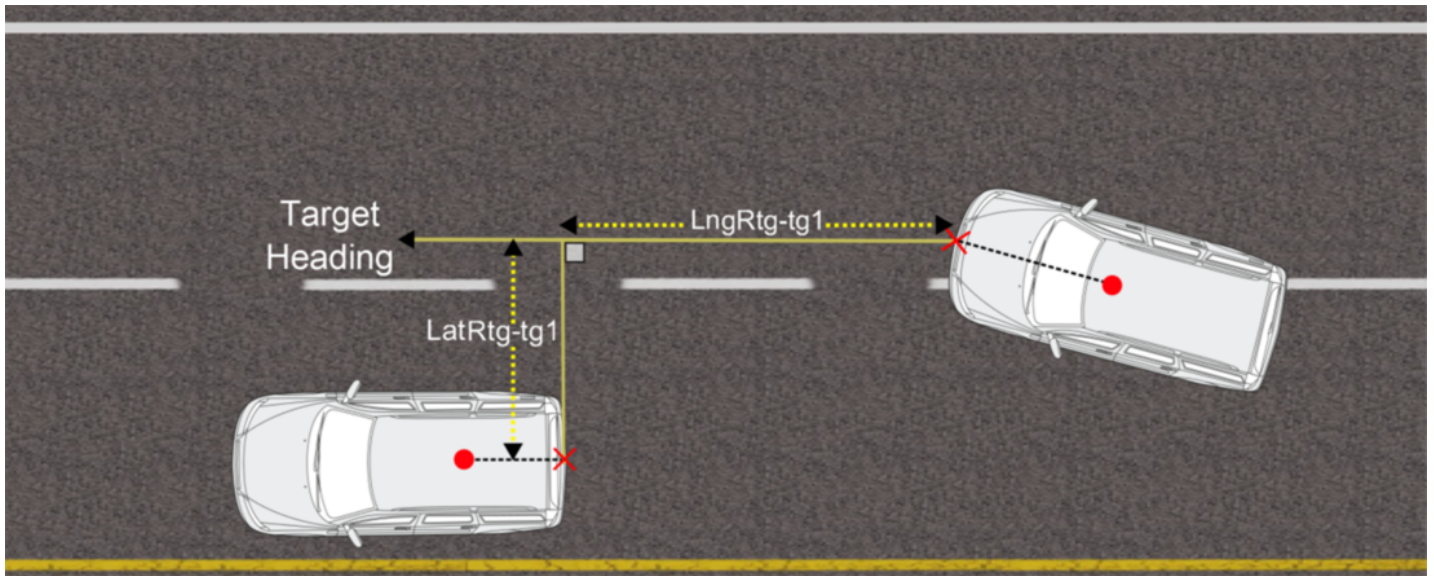

**LngRtg-tg1 and LatRtg-tg1 parameter definition**

\*Target Heading is a standard channel logged in the Target Vehicle, but only used in calculations at the Subject Vehicle

**‘LngRref-tg1’, ‘LatRref-tg1’**

Longitudinal and lateral difference between two vehicles based on an external reference heading.

It is a requirement of the National Highway Traffic Safety Administration “Forward Collision Warning System NCAP Confirmation Test March 2012” confirmation tests that the Subject Vehicle (SV) remains within 0.6 m of the centre line of the Target Vehicle (in the standard referred to as Principle Other Vehicle - POV).



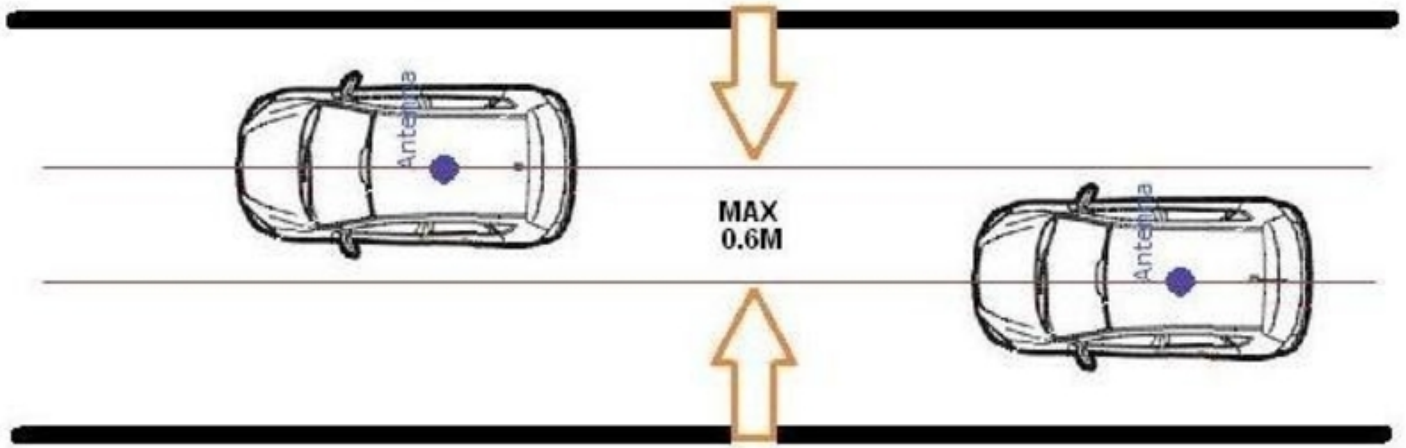

### Range calculations using a reference lane for NHTSA FCWS confirmation test

If this Lateral Range channel was based purely on vehicle heading then the resultant value would be extremely susceptible to noise. Small fluctuations in the Subject or Target Vehicle heading will result in fluctuations in Lateral Range greater than the NHTSA standard, the following example demonstrates this principle:

Heading fluctuation of  $0.5^\circ$  over a vehicle separation of 100 m:

$$\tan 0.5 \times 100 = 0.87m$$

By using a Reference lane heading a very stable Lateral Range channel is generated. Please click [here](#) for details on how to record a reference lane.





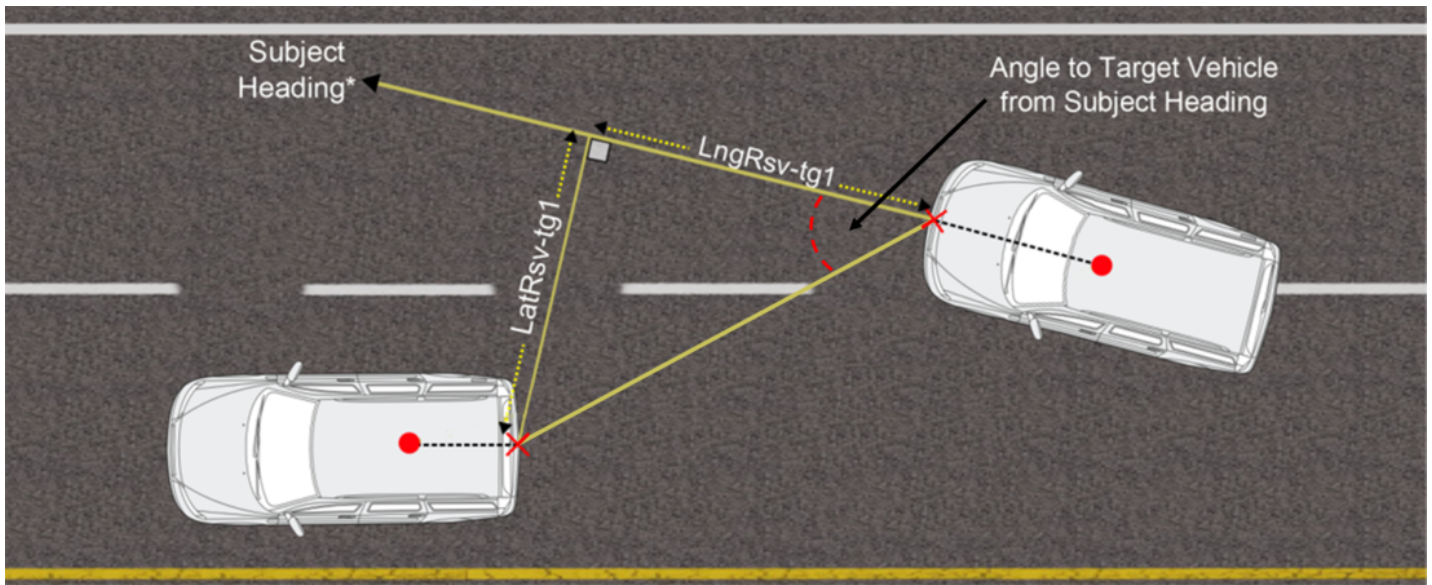

**LatRreftg1 calculations using a heading of a reference lane**

## Time To Collision (TTC)

### T2Csv-tg1

Time to collision based on Longitudinal Range from subject vehicle to Target vehicle based on subject vehicle heading and Longitudinal Speed.

$$T2Csv\_tg1 = \frac{LngRsv\_tg1}{Speed - (spd\_tg1 * COS(yawdif\_tg1))} * 3.6$$

### T2C2sv-tg1

Time to collision taking into account a decelerating target vehicle

NHTSA provide the following equation to account for a decelerating target vehicle in test 2 of their FCWS NCAP confirmation test.





$$T2C2sv\_tg1 = \frac{-(V_{pov} - V_{sv}) + \sqrt{(V_{pov} - V_{sv})^2 - 2 \times a_{pov} \times S_{sv}}}{a_{pov}}$$

$V_{pov}$  = Velocity of Principle Other Vehicle (Target Speed)

$V_{cv}$  = Velocity of Subject Vehicle (Speed)

$a_{pov}$  = Acceleration of Principle Other Vehicle (Target Accel)

$S_{sv}$  = Longitudinal distance from Subject Vehicle to Target Vehicle (LngRange)

### T2Ctg-tg1

Time to collision based on Longitudinal Range from subject vehicle to Target vehicle based on target vehicle heading and Target vehicle longitudinal Speed.

$$T2Ctg\_tg1 = \frac{LngRtg\_tg1}{Speed * COS(yawdif\_tg1) - spd\_tg1} * 3.6$$

### Link Time 'LkTime-tg1'

This channel is a time based incremental value based on Target Vehicle UTC time. A good link will show a trace incrementing every 10 ms with no drops to zero. Once this value reaches 65535 it is reset to zero.

Link Time is a good indicator of ADAS radio link quality, If this incremental count drops out and falls to zero then it is a likely indication that the ADAS radio link has intermittently failed.

The VBOX ADAS system will suffer occasional single sample drops outs, which are acceptable but larger periods of time with full or intermittent drop outs are an indicator of a Radio problem that needs addressing.

See also section [Radio Link](#)



## Separation time; SepTim-tg1

For Adaptive Cruise control testing; time it would take the Subject Vehicle to travel across the Vehicle separation distance at its current speed.

$$SepTime\_tg1 = \frac{LngRsv\_tg1}{Speed(\frac{m}{s})}$$

## App Mode

This channel indicates the current operating mode of the VBOX.

App Mode Value	Description
1	Normal
2	Target
4	Subject
8	Static
10	Lane departure - lane 1
0x50	Lane departure - lane 2
0x90	Lane departure - lane 3



## Lane Departure Measured Parameters

The following table provides a list of extra channels capable of being logged in the Subject Vehicle during a lane departure warning system test.

Channel Name	Channel Description	Units
Range_FL	Lateral Distance to Line from vehicle front left point	m
Range_FR	Lateral Distance to Line from vehicle front right point	m
Range_RL	Lateral Distance to Line from vehicle rear left point	m
Range_RR	Lateral Distance to Line from vehicle rear right point	m
TTC_FL	Time To Line cross, wrt to vehicle front left point	s
TTC_FR	Time To Line cross, wrt to vehicle front right point	s
TTC-RL	Time To Line cross, wrt to vehicle rear left point	s
TTC_RR	Time To Line cross, wrt to vehicle rear right point	s
LatSpd_FL	Lateral speed toward line wrt to vehicle front left point	km/h
LatSpd_RR	Lateral speed toward line wrt to vehicle rear right point	km/h
LatSpd_RL	Lateral speed toward line wrt to vehicle rear left point	km/h
LatSpd-FR	Lateral speed toward line wrt to vehicle front right point	km/h
Angle	The Angle between the vehicle heading and the tangent of the reference lane at the point where range is calculated	°



A number of the parameters shown in the table above are outlined in schematics over the next few pages in order to give a clear visualisation of how they are calculated.

## Range\_Lt Calculation

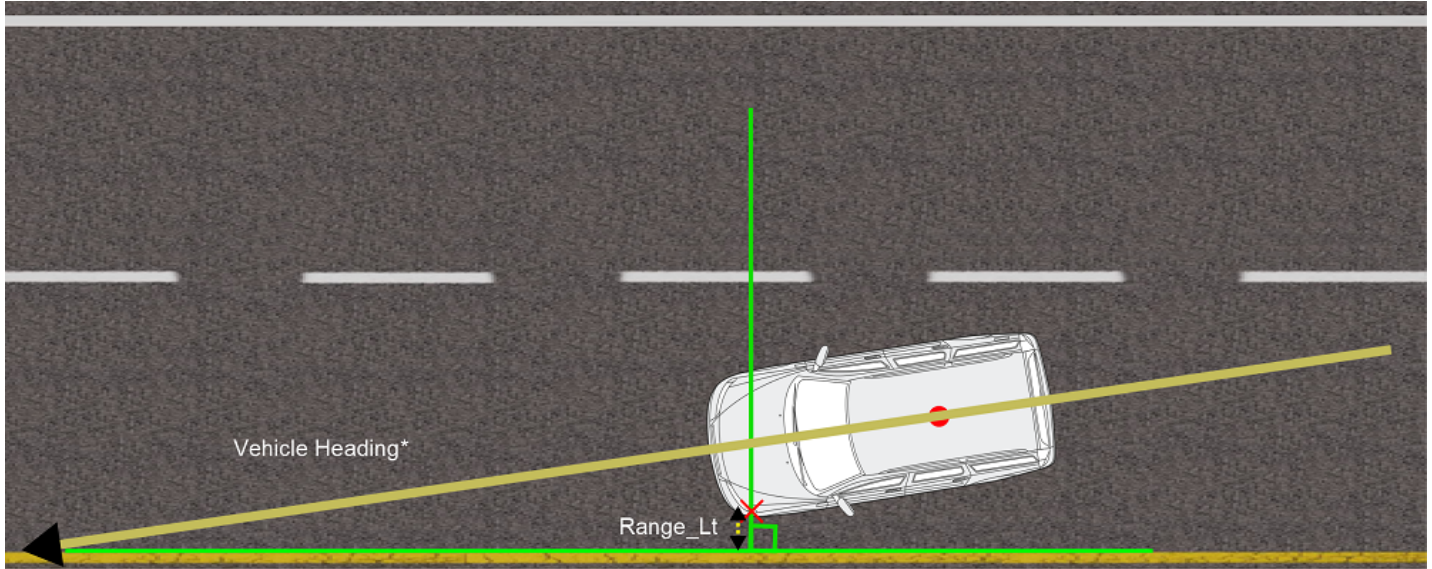

**Range\_Lt parameter calculation**

The value for Range\_Lt is the shortest perpendicular distance between the offset and the surveyed lane.

## LatSpd-Lt;

Lateral speed of the left hand offset point with respect to the marked lane edge.

$$\text{LatSpd-Lt} = V_{\text{fwd}} * \text{Sin}(\alpha)$$

$V_{\text{fwd}}$  = GPS velocity (course over ground)

$\alpha$  = Lane edge Heading – Heading at Vehicle offset point.



## Range\_Rt Calculation

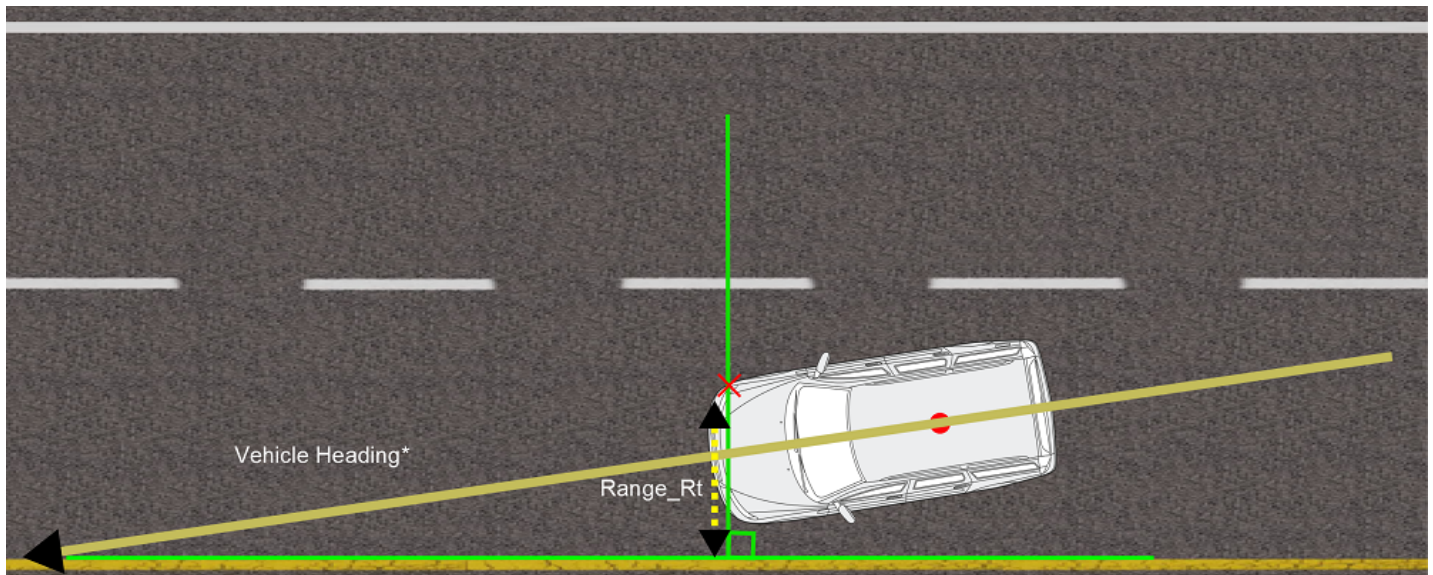

**Range\_Rt parameter calculation**

The value for Range\_Rt is the shortest perpendicular distance between the offset and the surveyed lane.

### LatSpd-Rt;

Lateral speed of the right hand offset point with respect to the marked lane edge.

$$\text{LatSpd-Rt} = V_{\text{fwd}} * \sin(\alpha)$$

$V_{\text{fwd}}$  = GPS velocity (course over ground)

$\alpha$  = Lane edge Heading – Heading at Vehicle offset point.





## Angle Calculation

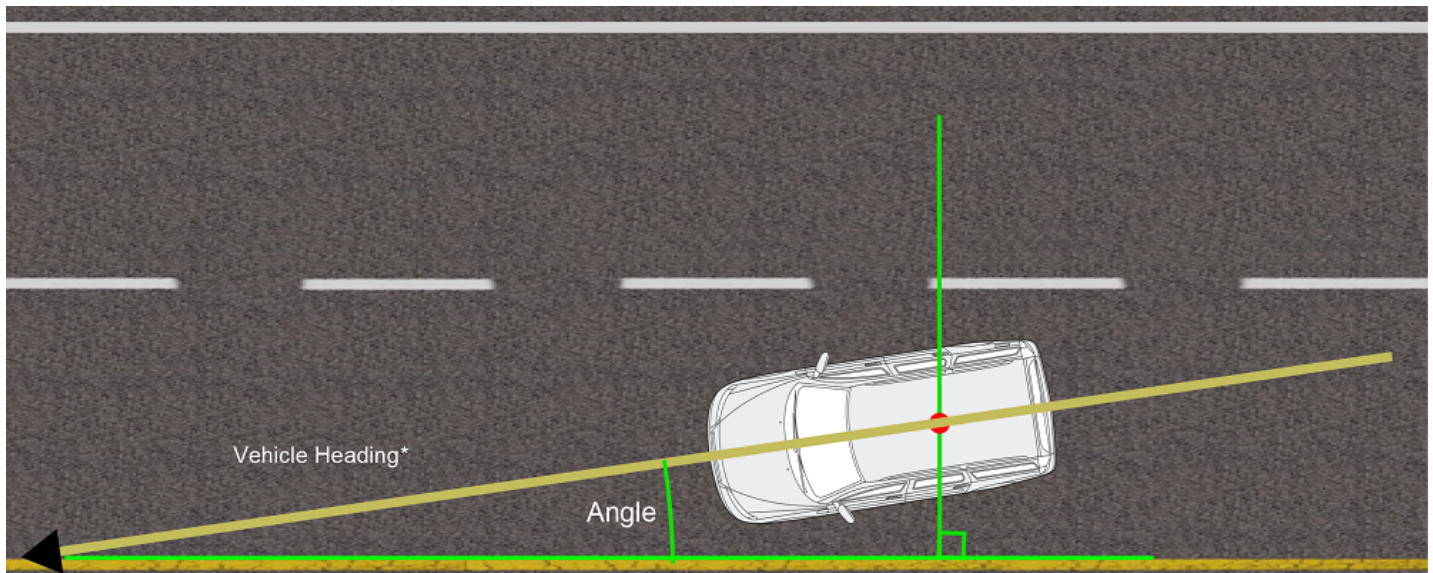

**Angle parameter calculation**

The value of Angle is the angle between the vehicle heading and the tangent of the surveyed lane at the shortest perpendicular distance to the GPS antenna.

### TTC-FL; TTC-FR; TTC-RL; TTC-RR

Time to cross the reference lane calculated from the Front Left, Front Right, Rear Right or Rear Left offset point range and lateral speed.

e.g.  $TTC-FR = \text{Range\_FR (metres)} / \text{LatSpd\_FR (m/s)}$



## Lane Departure Calculations Around A Curve

When testing a Lane Departure Warning System around a curved lane the VBOX firmware takes measurements from the corner position to the nearest perpendicular tangent line to the curved lane edge, as shown below.

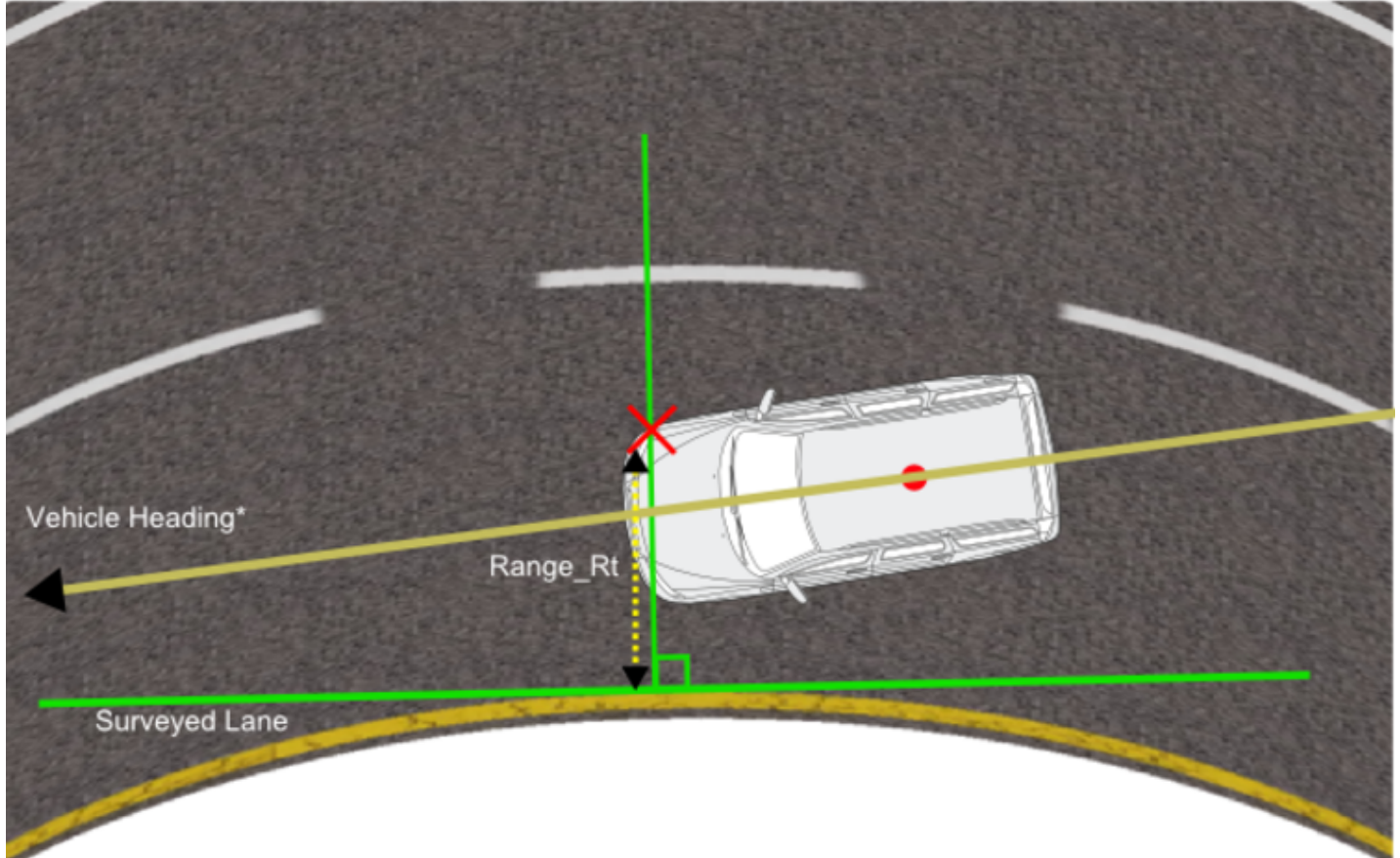

**Determining range from a curved lane**



---

## Multi Static Point Measured Parameters

The following table provides a list of extra channels capable of being logged in the Subject Vehicle during a multi static point test.

Channel Name	Description	Units
ID (1-5)	The point number of the feature currently occupying ID 1/2/3/4/5	N/A
Range (1-5)	The direct distance between the measurement point and the feature in ID 1/2/3/4/5	m
Lat_Range (1-5)	The Lateral distance between the measurement point and the feature in ID 1/2/3/4/5 measured at right angles to the subject vehicle's heading	m
Lng_Range (1-5)	The Longitudinal distance between the measurement point and the feature in ID 1/2/3/4/5 measured in the direction of the subject vehicle's heading	m
Angle (1-5)	The angle to the feature in ID 1/2/3/4/5 with respect to the subject vehicles heading	°

